



**SPECIAL PROVISIONS
FOR
GROUTED SPLICE COUPLER MOCKUP**

**Mahaska County
BRF-092-7(45)--38-62**

**Effective Date
November 17, 2020**

THE STANDARD SPECIFICATIONS, SERIES 2015, ARE AMENDED BY THE FOLLOWING MODIFICATIONS AND ADDITIONS. THESE ARE SPECIAL PROVISIONS AND THEY SHALL PREVAIL OVER THOSE PUBLISHED IN THE STANDARD SPECIFICATIONS.

150703.01 DESCRIPTION.

- A.** This work consists of furnishing all labor, materials, and equipment necessary to demonstrate Contractor's ability to successfully install a grouted splice coupler by preparing a mockup as specified in this document or as directed by the Engineer.
- B.** After completion of mockup, couplers shall be tested to verify grouted splice connections meet requirements specified in this document.
- C.** The Contractor shall only use grouted splice couplers and related materials in the construction of the project that successfully meet the requirements of this special provision.
- D.** The installation procedure for the grouted splice coupler mockups shall match the procedure used for the construction of the grouted slice couplers shown in the plans and meet the requirements of this special provision.
- E.** This special provision only applies if the contractor elects to construct the precast pier cap option shown in the plans.

150703.02 MATERIALS.

A. Grouted Splice Couplers

- 1.** Use grouted splice couplers to join precast elements as shown on the plans. The coupler shall be specifically designed to join reinforcing steel from within a precast concrete pier cap element to projecting bars from an adjacent cast-in-place concrete drilled shaft element. The couplers shall use cementitious grout placed inside a steel casting to develop the strength of the connection. Threaded connections may be used for the portions of the coupler that are

placed within the precast element if the strength of the coupler meets or exceeds the requirements of this specification.

2. The following grouted splice couplers are acceptable for use provided that the requirements of this special provision are met. Contractor may submit another product as an approved equal, subject to approval by the Engineer.
 - a. NMB Splice Sleeve
Splice Sleeve North America, Inc.
38777 West Six Mile Road, Suite 205
Livonia, MI 48152
www.splicesleeve.com
 - b. Dayton Superior DB Grout Sleeve
Dayton Superior Corporate Headquarters
1125 Byers Road
Miamisburg, OH 45342
www.daytonsuperior.com
 - c. Erico Lenton Interlok
ERICO United States
34600 Solon Road
Solon, Ohio 44139
www.erico.com
3. The grouted splice couplers shall provide 150% of the yield tensile strength of the connected bar.

B. Splice Coupler Grout Material.

The grout used for the inside of the couplers shall be supplied by the manufacturer of the coupler. The grout shall be matched with the coupler and be the same grout as specified in the certified test report for the coupler. No other grout shall be substituted in the couplers unless additional certified test reports are submitted for the grout/coupler system.

C. Structural Non-Shrink Grout.

1. Use structural, gray, non-shrink grout for joints between drilled shaft and precast pier cap, as shown on the plans. Structural non-shrink grout shall meet Materials I.M. 491.13 and the following requirements:
2. Non-shrink grout shall be quicksetting, rapid strength gain, high-bond strength grout. Grout shall not contain calcium chloride or admixture containing calcium chloride or other ingredient in sufficient quantity to cause corrosion to steel reinforcement. Mix grout just prior to use according to the manufacturer's instructions.
3. Use structural non-shrink grout that meets a minimum compressive strength of 4000 psi within 24 hours and 5000 psi within 28 days when tested as specified in AASHTO T 106. Use structural non-shrink grout with no expansion after seven days.

D. Steel Reinforcement.

Use reinforcing steel for the mockup with same size, grade, coating, and properties to be used for the grouted splice couplers shown on the plans.

150703.03 CONSTRUCTION.

A. Submittals.

1. General.

Provide submittals to the Engineer in electronic format, in accordance with Article 1105.03 of the Standard Specifications.

2. Grouted Splice Couplers.

- a. Submit an electronic copy of an independent test report confirming the compliance of the coupler, for each supplied coupler size, with the following requirements:
 - 1) Develop 150% of the yield tensile strength of the attached reinforcing bar.
 - 2) Determine through testing, the amount of time required to provide 125% of the specified minimum yield strength of the attached reinforcing bar. Use this value to develop the assembly plan timing.
- b. Use the same grout in the mockup construction that was used in the testing.
- c. Submit the specification requirements for the grout including required strength gain to develop the specified minimum yield strength of the connected reinforcing bar.

B. Grouted Splice Coupler Mockup.

1. The contractor shall construct two grouted splice coupler connection mockups for testing by the Contractor to demonstrate the coupler grouting process to the Engineer. See Appendix A for details of the mockup.
2. The mockup shall utilize the same grouted splice coupler and grout material detailed in the independent test report. The intent of mockup demonstration is to represent the actual bridge elements and situation as best as possible.
3. Each mockup will consist of two parts.
 - a. Part 1 will represent the precast cap and will include grouted splice coupler encased in a concrete cylinder with a length of rebar matching the size used in the connection shown in the plans. Rebar shall be exposed for tension testing at one end and within the splice coupler by the length specified by the supplier.
 - b. Part 2 will represent the cast-in-place drilled shaft and will consist of concrete base with a length of rebar exposed at both ends. Concrete base shall be same diameter as Part 1 and a minimum of 3 inches thick. One end of rebar will be exposed for tension testing, the other exposed for insertion into the splice coupler connection by the length specified by the supplier.
 - c. Parts will be connected by structural non-shrink grout, while in vertical upright position to represent actual bridge positioning.
 - d. Once non-shrink grout is cured, mockup is ready to apply splice coupler grout mix.
4. At least one representative of the grouted splice coupler supplier must be onsite during the demonstration of coupler grouting process to answer questions and provide assistance as required.
5. Mockups shall be produced at least 30 days before production of the precast pier cap to allow time for adequate curing, testing, and final evaluation by the Engineer. Construction of the precast pier cap may not proceed until final approval of grouting procedure is given by the Engineer.

C. Quality Assurance.

The performance of grouted splice couplers is related to the embedment length of the bars and the compressive strength of the grout. The following requirements for grouted splice couplers shall be met:

1. Check the length of rebar anchor dowel to make sure they meet the minimum embedment specified in the manufacturer's manual.

2. Monitor shim thickness between the precast and cast-in-place elements to ensure that the reinforcing extensions are within the manufacturers recommended tolerance.
3. Monitor the grout mixing, water to grout ratio, mixing time, and shelf life of the grout for conformance with the manufacturers written instructions.
4. Monitor the grouting operation to verify that all sleeves have been filled.
5. Verify that all sleeves are protected from any vibration, shock, or other excessive movement until temporary bracing is removed.
6. Check the temperature of the sleeve at the time of grouting (50°F minimum) and during curing.

D. General Connection Procedure Using Grouted Splice Couplers.

1. Use personnel that are familiar with installation and grouting of splice couplers that have completed at least two successful projects in the last two years. Training of new personnel within three months of installation by a manufacturer's technical representative is an acceptable substitution for this experience.
2. Remove and clean all debris from the joints prior to application of non-shrink grout. Keep bonding surfaces free from laitance, dirt, dust, paint, grease oil, or any contaminants other than water.
3. Saturate Surface Dry (SSD) all joint surfaces prior to connecting the elements.
4. Use heaters in freezing temperatures to maintain a minimum temperature of 50°F. Monitor the temperature of the covered sleeves until the temporary bracing, if used, is removed.
5. Follow the recommendations of the manufacturer for the installation and grouting of the couplers. The installation shall generally be as follows:
 - a. It is recommended that the projecting reinforcing bars from the adjacent element be cast longer than required and cut to length in the field after the top of shims, if used, have been set. Follow the manufacturer's recommendations for the projection length of the bars measured from the top of the shims to the top of the bars.
 - b. Mix the non-shrink grout according to the supplier's recommendations including preparation and application.
 - c. Place non-shrink grout on the interface between the two elements being joined prior to setting the element. Crown the thickness of the grout toward the center of the joint so that the grout can be displaced outward as the element is lowered onto the joint. Take precautions to prevent the non-shrink grout from entering the coupler above (e.g. grout dams or seals).
 - d. Set the element in place. Engage all couplers in the joint. Allow the non-shrink grout to seep out of the joint.
 - e. Trowel off excess non-shrink grout to form a neat joint once the element is set, plumbed, and aligned. Pack grout into any voids around the joint perimeter.
 - f. Flush out the coupler with clean potable water
 - g. Mix the splice coupler grout according to the manufacturer's recommendations for methods and proportions of mix and water.
 - h. Pump the coupler grout into the coupler that is cast into the element. Start from the lower port. Pump until the grout is flowing freely from the upper port.
 - i. Cap the upper port first and then remove the nozzle to cap the lower port. Proceed to the next coupler, as required.
 - j. Cure the joint according to the non-shrink grout manufacturer's recommendations.

E. Material Testing.

1. The results shall be signed and sealed by an engineer licensed and registered in the State of Iowa. The results shall be provided as arranged with the Engineer, to meet the closure schedule and requirements for opening the Bridge.
2. Tension tests shall be performed in accordance with ASTM A370. The specimens shall be tested to validate achievement of the 150% of the yield tensile strength of the attached reinforcing bar. Determine through testing, the amount of time required to provide 125% of the specified minimum yield strength of the attached reinforcing bars.
3. If a splice coupler mockup fails testing, Contractor shall repeat demonstration with two new grouted splice coupler mockups.

150703.04 METHOD OF MEASUREMENT.

A. Grouted Splice Coupler Mockup.

The method of measurement will be Lump Sum.

B. Grouted Splice Couplers.

No method of measurement. Grouted splice couplers shall be incidental to the precast concrete element the grouted splice couplers are cast within.

150703.05 BASIS OF PAYMENT.

A. Grouted Splice Coupler Mockup.

Payment for Grouted Splice Coupler Mockup will be the Lump Sum contract price. Payment will be full compensation for furnishing all submittals, materials, labor, testing, and incidental work to complete the Grouted Splice Coupler Mockup as indicated in this special provision and the contract documents.

B. Grouted Splice Couplers.

Grouted splice coupler will not be paid for separately but shall be considered incidental to the precast concrete item the grouted splice couplers are cast within.

APPENDIX A

GROUTED SPLICE COUPLER MOCKUP

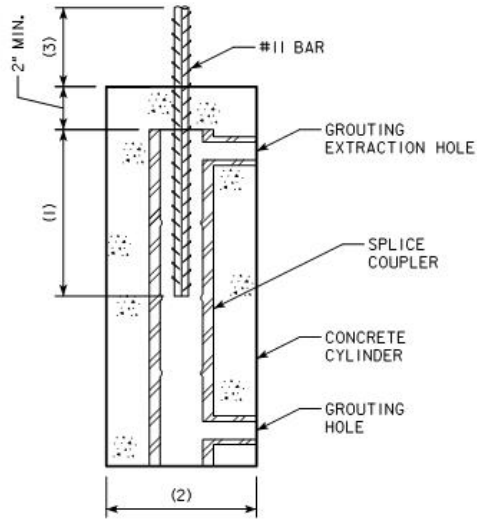

PART 1
(REPRESENTING PRECAST PIER CAP)

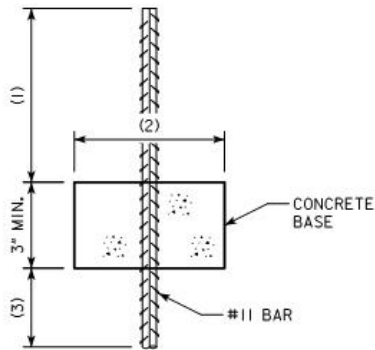

PART 2
(REPRESENTING CIP DRILLED SHAFT)

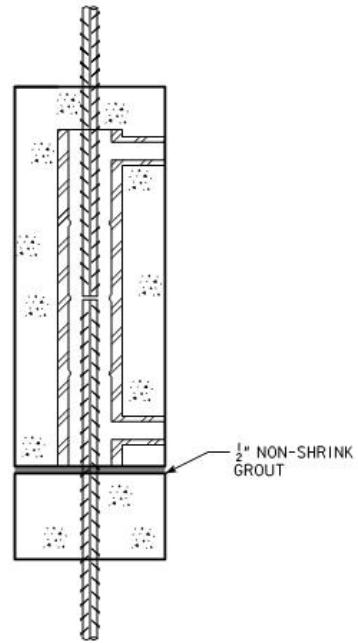

COMBINED PARTS
(MOCKUP READY FOR GROUT SPLICE CONNECTION DEMONSTRATION)

- (1) SPECIFIED BY SUPPLIER
- (2) 6" MIN. PROVIDE 2" CLEAR COVER AROUND SPLICE COUPLER.
- (3) 9" MIN. VERIFY WITH MATERIAL TESTER