

FRONT ELEVATION

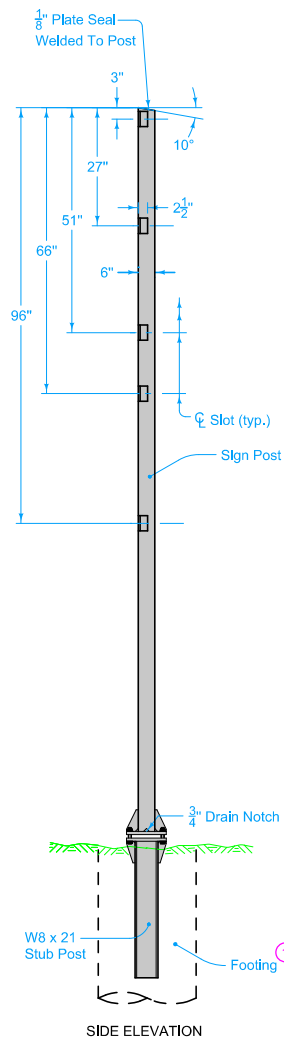

SIDE ELEVATION

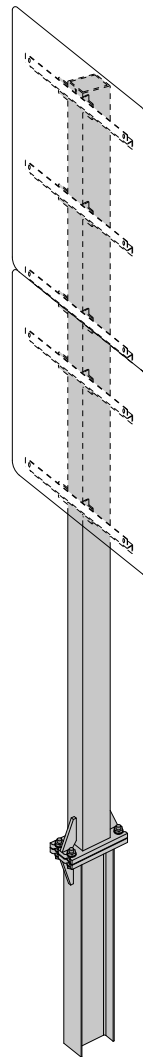

OBLIQUE FRONT VIEW

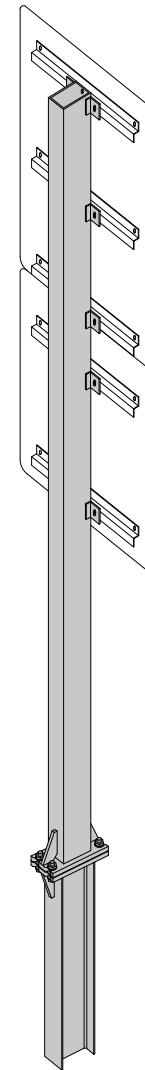

OBLIQUE BACK VIEW

Plumb signpost by installing brass stock or strip shims complying with ASTM B 36. Furnish two shims each of 0.012" and 0.032" thickness (total of 4 per post).

① Refer to Standard Road Plan SI-112 for footing information.

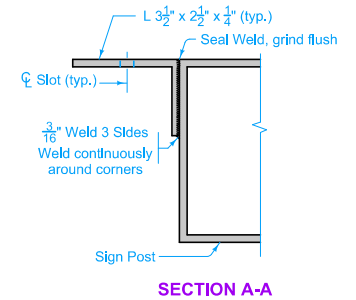

Possible Contract Item:  
Steel Breakaway Sign Post, Rectangular Tube

<b>IOWA DOT</b>	REVISION	
	3	04-19-16
	<b>STANDARD ROAD PLAN</b>	
<b>SI-114</b>		SHEET 1 of 2
REVISIONS: Moved footing information to SI-112. Changed title and added oblique views.		

*Brian Smith*  
APPROVED BY DESIGN METHODS ENGINEER

**FREWAY/EXPRESSWAY  
SPEED LIMIT  
SUPPORT POSTS**

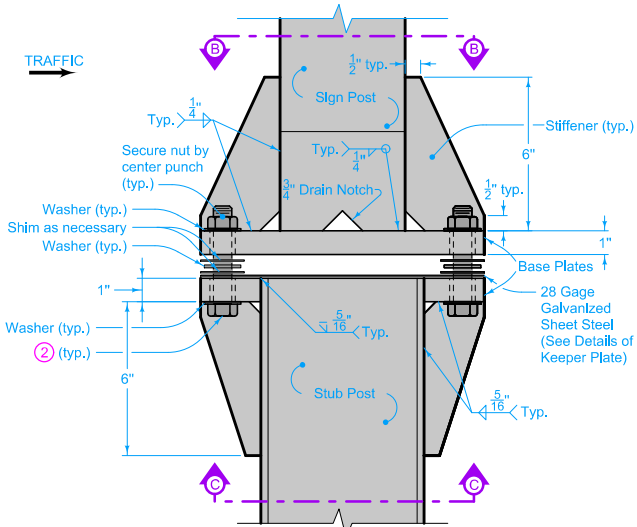

**BREAKAWAY BASE**  
Side View  
(Alternate 1)

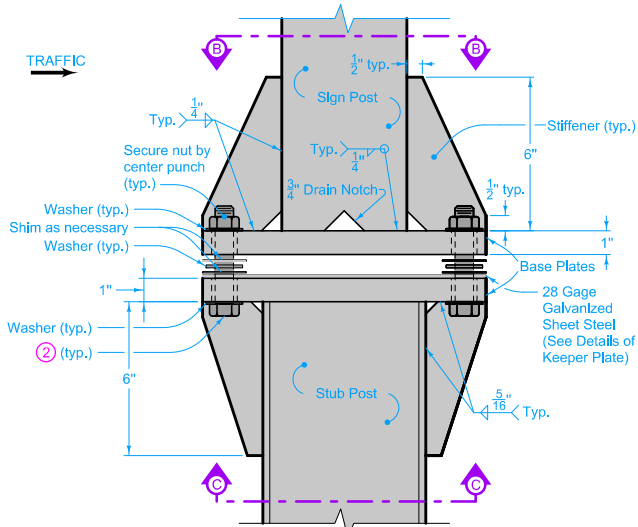

**BREAKAWAY BASE**  
Side View  
(Alternate 2)

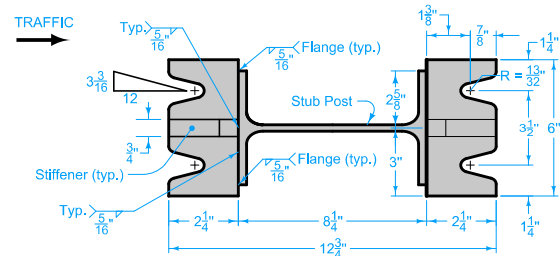

**SECTION C-C**  
PLAN - BASE  
(ALTERNATE 1)

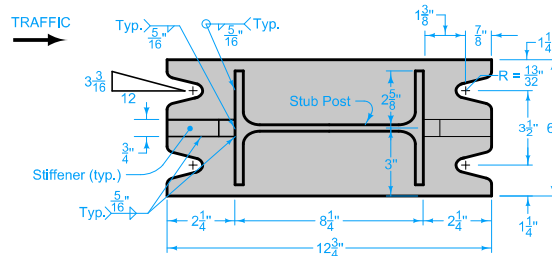

**SECTION C-C**  
PLAN - BASE  
(ALTERNATE 2)

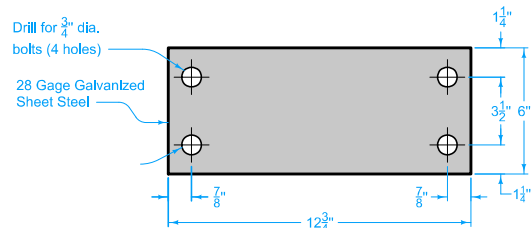

**KEEPER PLATE**

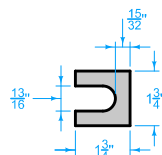

**SHIM**

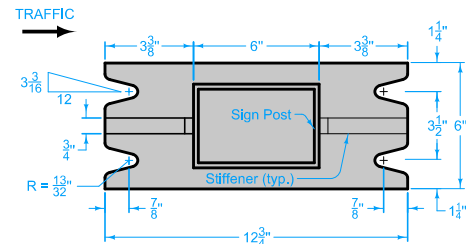

**SECTION B-B**  
PLAN - BASE

The following Base Plate alternates are considered equivalent:

ALTERNATE 1 - Weld base plates (2 each) to sides of stub post flanges.

ALTERNATE 2 - Weld base plate (1 each) to end of stub post. During assembly, properly match and align the bolt holes and notches in the stub post plate and the sign post plate as indicated hereon.

Grind smooth all welds and galvanizing between Base Plates.

- ② 3/4\"/>

<p><b>STANDARD ROAD PLAN</b></p> <p>REVISIONS: Moved footing information to SI-112. Changed title and added oblique views.</p> <p><i>Brian Smith</i> APPROVED BY DESIGN METHODS ENGINEER</p> <p><b>FREeway/EXPRESSWAY</b> <b>SPEED LIMIT</b> <b>SUPPORT POSTS</b></p>	<p>REVISION</p> <table border="1"> <tr> <td>3</td> <td>04-19-16</td> </tr> </table>	3	04-19-16
	3	04-19-16	
	<p><b>SI-114</b></p> <p>SHEET 2 of 2</p>		