

Standard W-Beam Guardrail

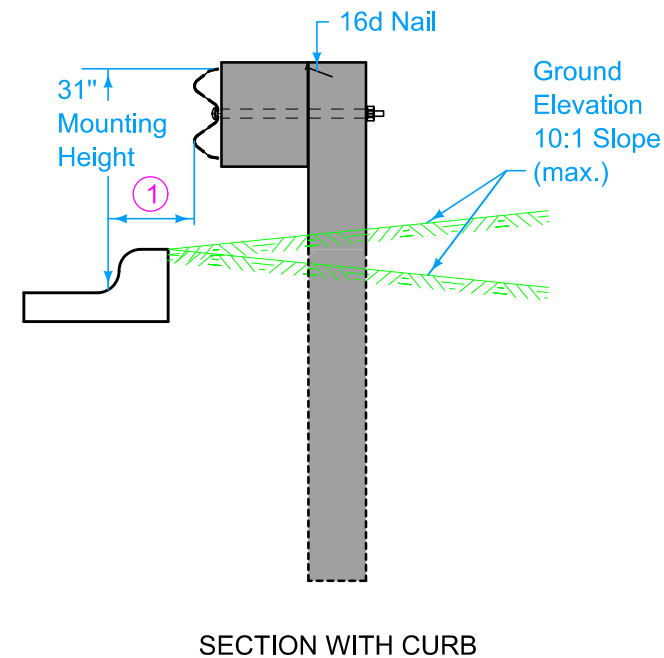
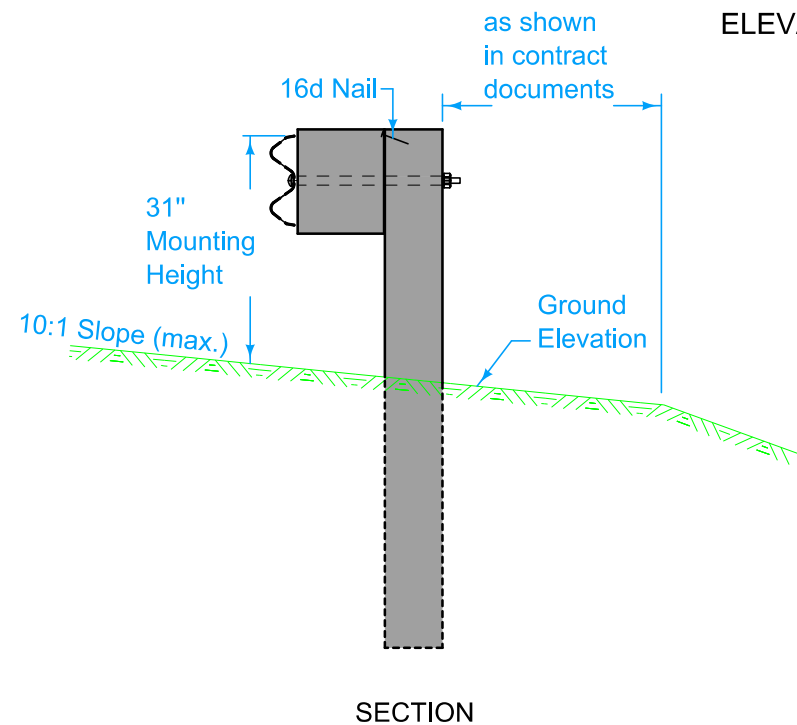
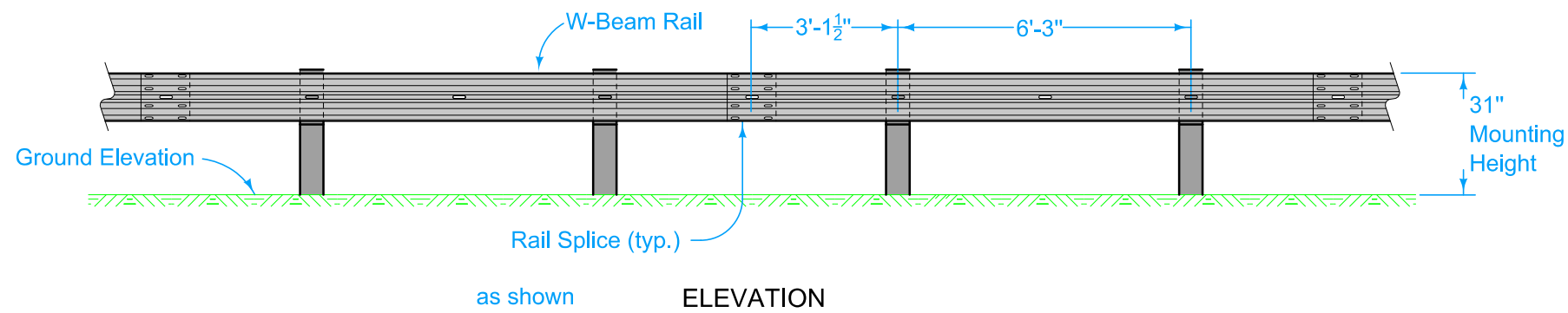
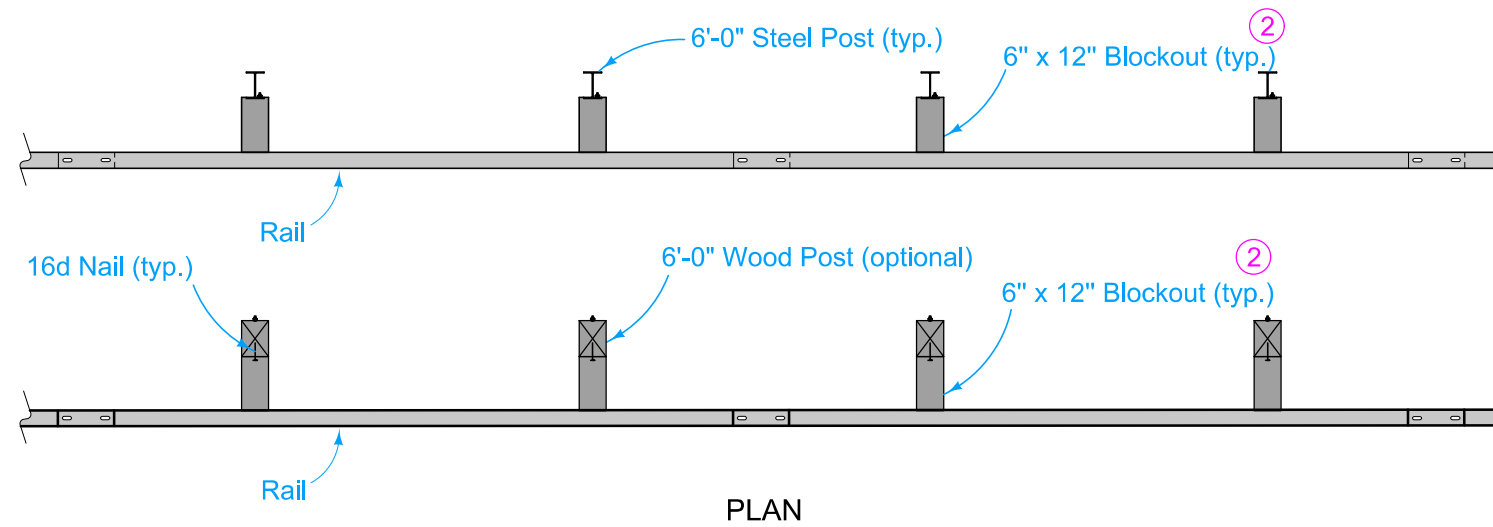

W-BEAM INSTALLATION

At Bridge End Drains, cut Scour Protection (Transition Mat and Turf Reinforcement Mat) or remove rock as required to place post(s) such that Bridge End Drains abut post(s).

- ① 6" maximum for 6" Standard or 6" Sloped curbs and for non-standard curbs.
- ② Wood or composite only. Steel blockouts will not be allowed.

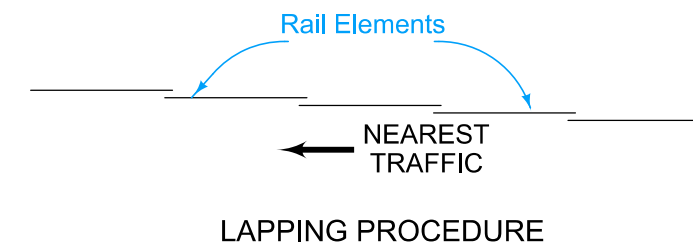

Possible Contract Item:
Steel Beam Guardrail

	REVISION	
	7	04-15-25
STANDARD ROAD PLAN		BA-200
		SHEET 1 of 5
REVISIONS: Removed half post spacing, added quarter post spacing		
APPROVED BY DESIGN METHODS ENGINEER		
STEEL BEAM GUARDRAIL COMPONENTS		

Quarter Post Spacing W-Beam Guardrail

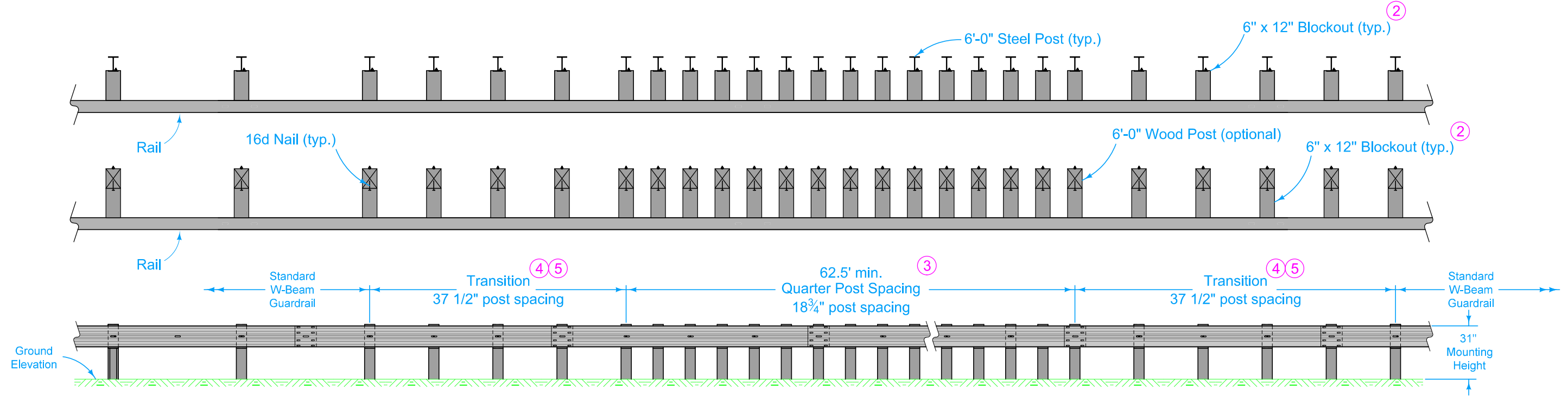

Elevation

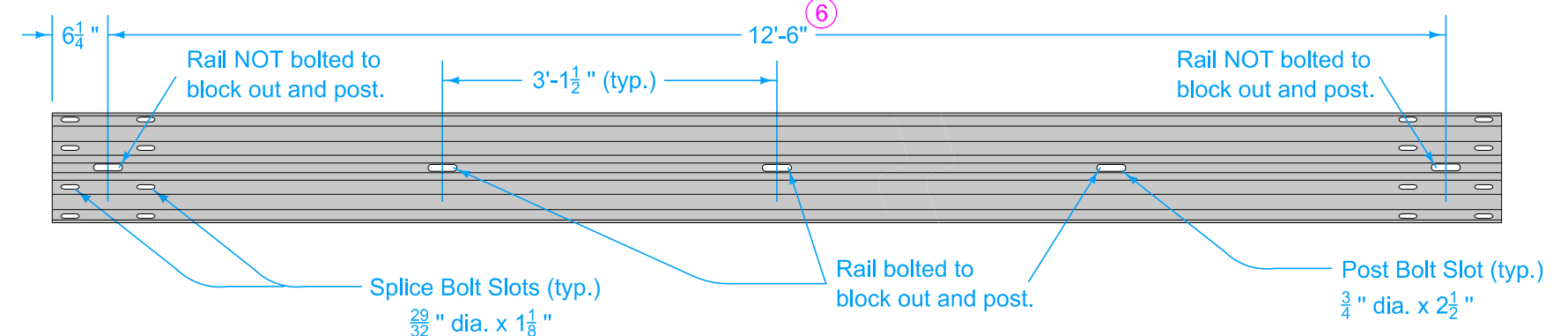

ELEVATION
W-BEAM RAIL

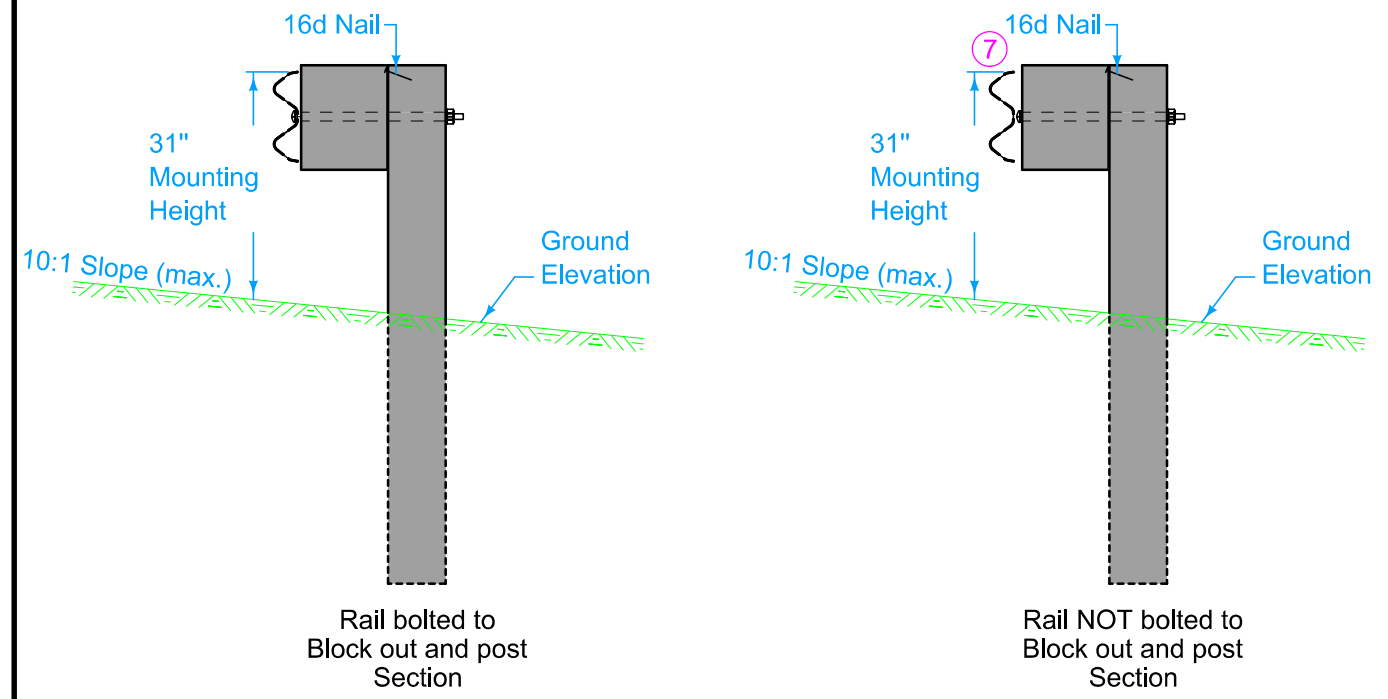

- ③ Posts and blockouts connect to rail at 37 1/2 inch spacing. Rail to not be bolted to post and blockouts at splice location.
- ② Wood or composite only. Steel blockouts will not be allowed.
- ④ Transition length minimum of 12 feet 6 inches.
- ⑤ Transition required at both ends of quarter post spacing.
- ⑥ 25 foot long section will not be allowed. Additional holes in rail will not be allowed.
- ⑦ At locations where the rail is not bolted to the post and block out the post and block out shall be bolted together.

<p>STANDARD ROAD PLAN</p>	REVISION	
	7	04-15-25
BA-200		SHEET 2 of 5
REVISIONS: Removed half post spacing, added quarter post spacing		
APPROVED BY DESIGN METHODS ENGINEER		
STEEL BEAM GUARDRAIL COMPONENTS		

STEEL POST AND BLOCKOUT DETAILS

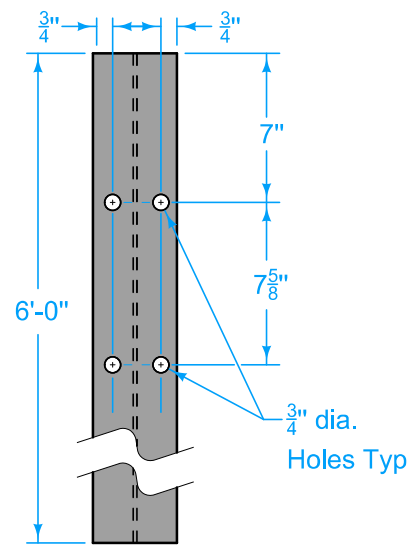

6'-0" STEEL POST
W6x9 or W6x8.5

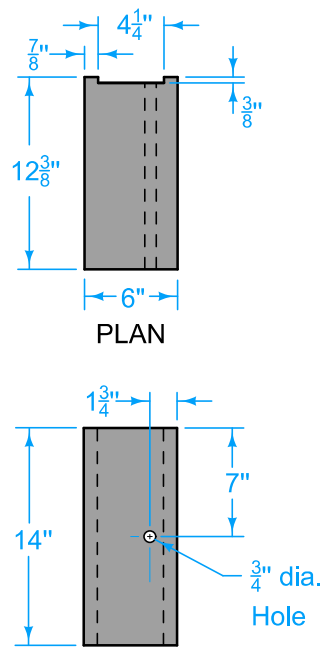

W-BEAM BLOCKOUT ⁽²⁾

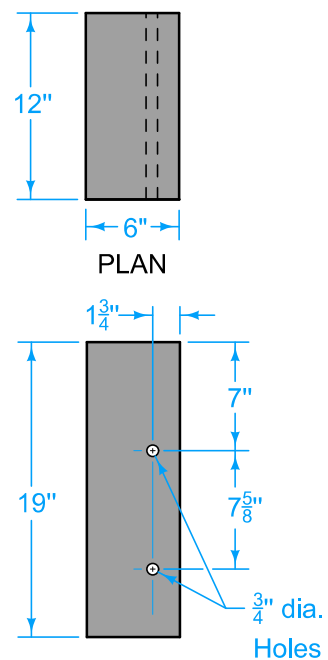

THRIE-BEAM BLOCKOUT ⁽²⁾

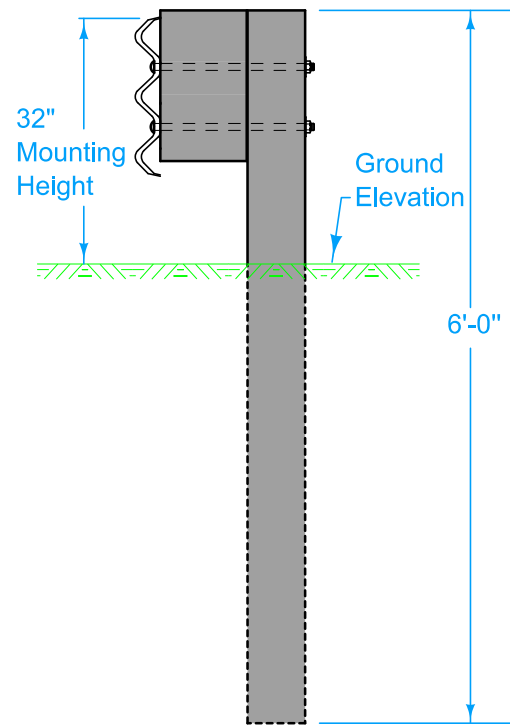

THRIE-BEAM INSTALLATION

- ⁽²⁾ Wood or composite only. Steel blockouts will not be allowed.
- ⁽⁸⁾ Thrie-beam post may be substituted for W-beam post.

WOOD POST AND BLOCKOUT DETAILS

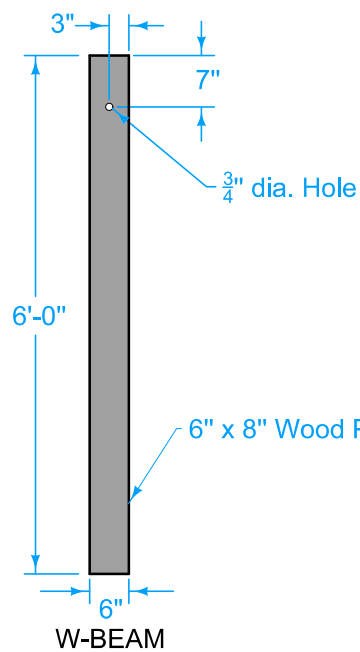

W-BEAM POSTS ⁽⁸⁾

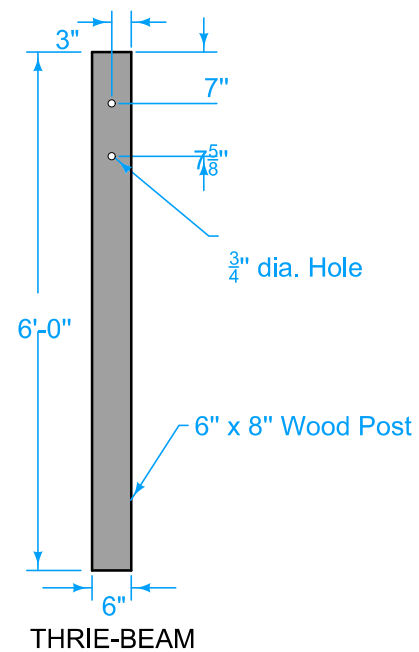

THRIE-BEAM

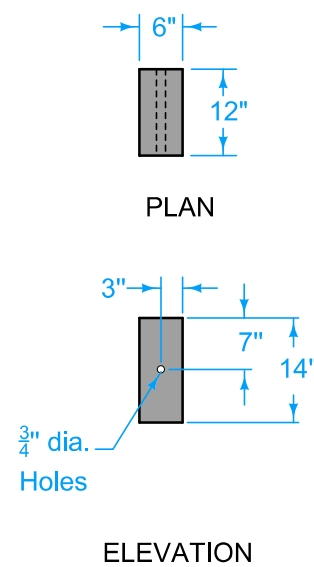

W-BEAM BLOCKOUT ⁽²⁾

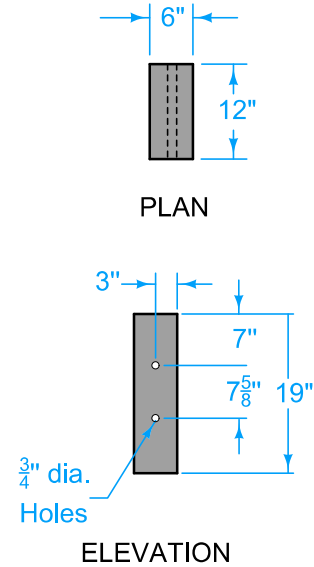

THRIE-BEAM BLOCKOUT ⁽²⁾

BOLT DETAILS

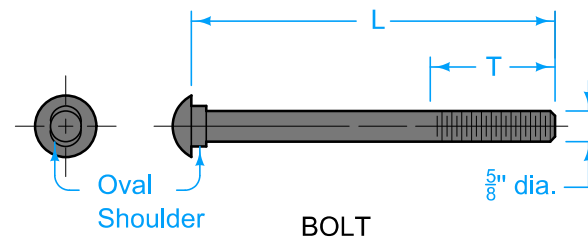

BOLT

APPLICATION	T	L
Splice Bolt	1 1/16"	1 1/4"
Bolt for Steel Post with 8" Blockout	2 1/2"	10"
Bolt for Steel Post with 12" Blockout	2 1/2"	14"
Bolt for Wood Post with 8" Blockout	2 1/2"	18"
Bolt for Wood Post with 12" Blockout	2 1/2"	22"

T = Min. Thread Length L = Bolt Length

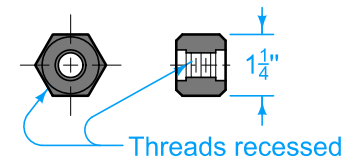

NUT

HARDWARE

IOWA DOT

STANDARD ROAD PLAN

REVISIONS: Removed half post spacing, added quarter post spacing

APPROVED BY DESIGN METHODS ENGINEER

REVISION	7	04-15-25
BA-200		
SHEET 3 of 5		

STEEL BEAM GUARDRAIL COMPONENTS

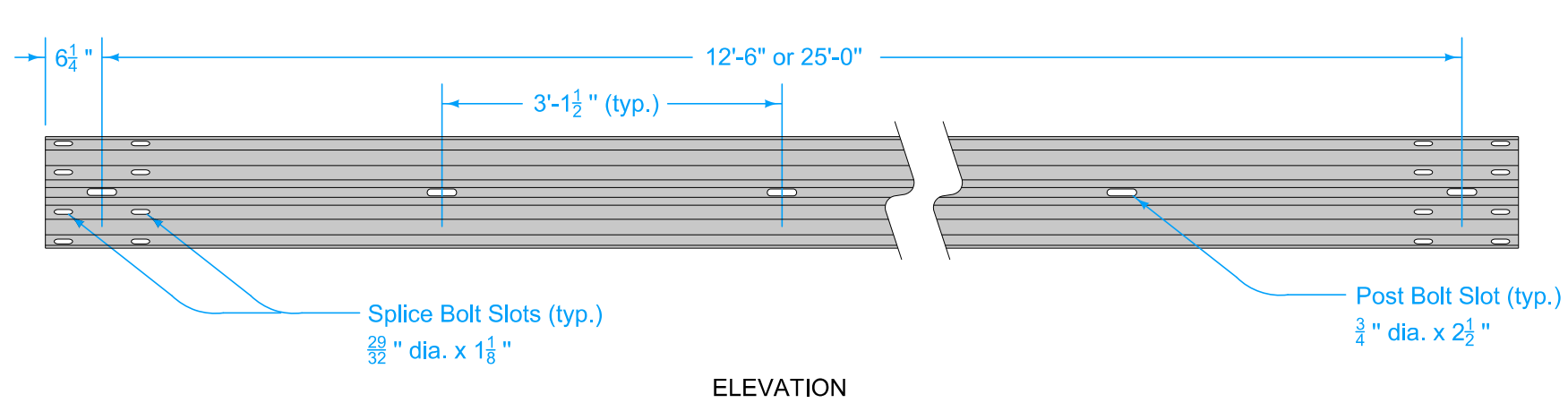

W-BEAM RAIL

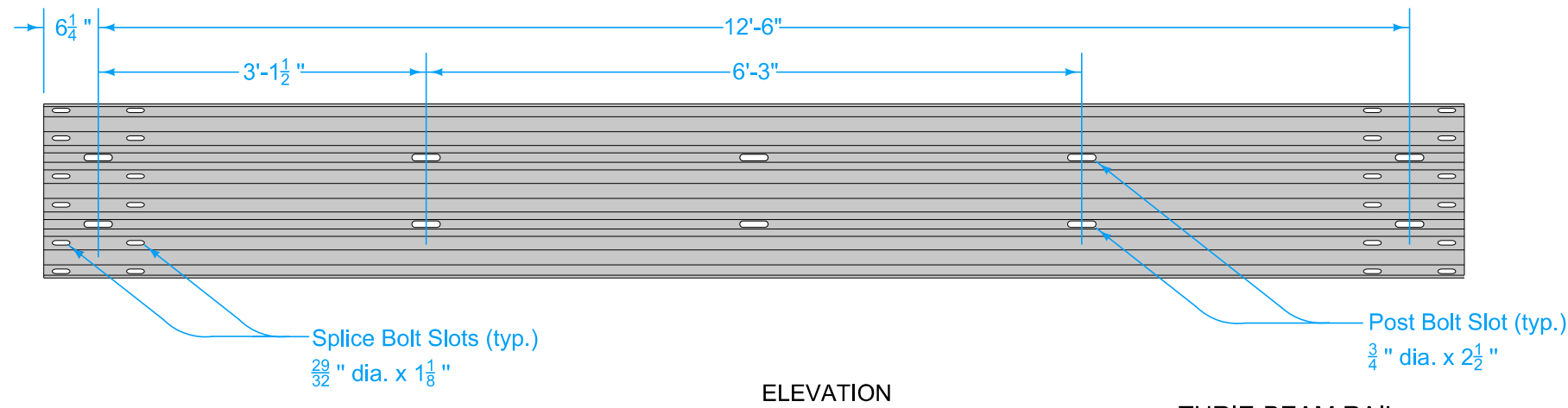
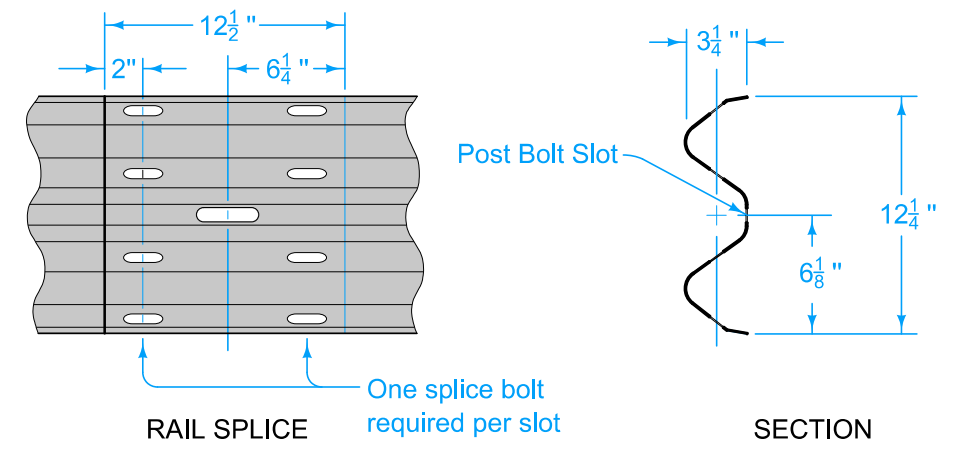

THRIE-BEAM RAIL

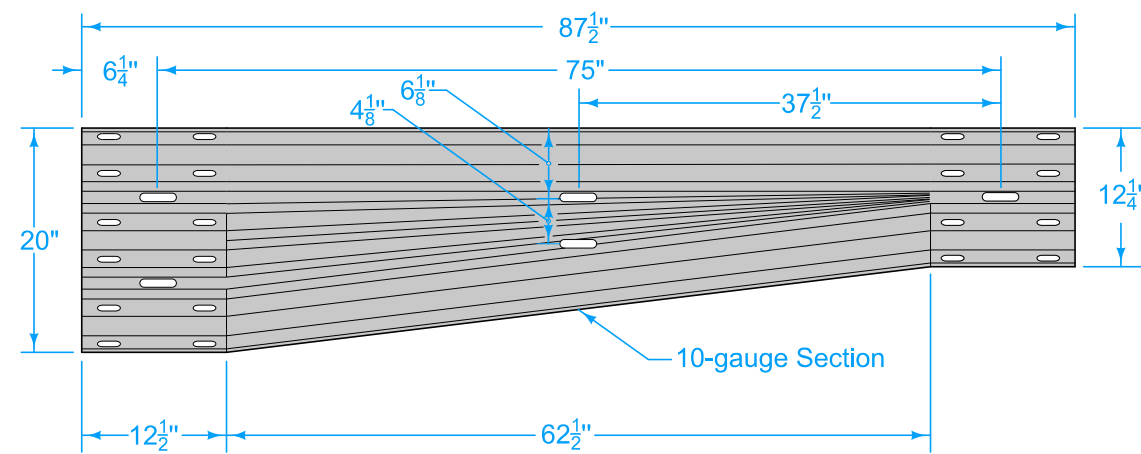
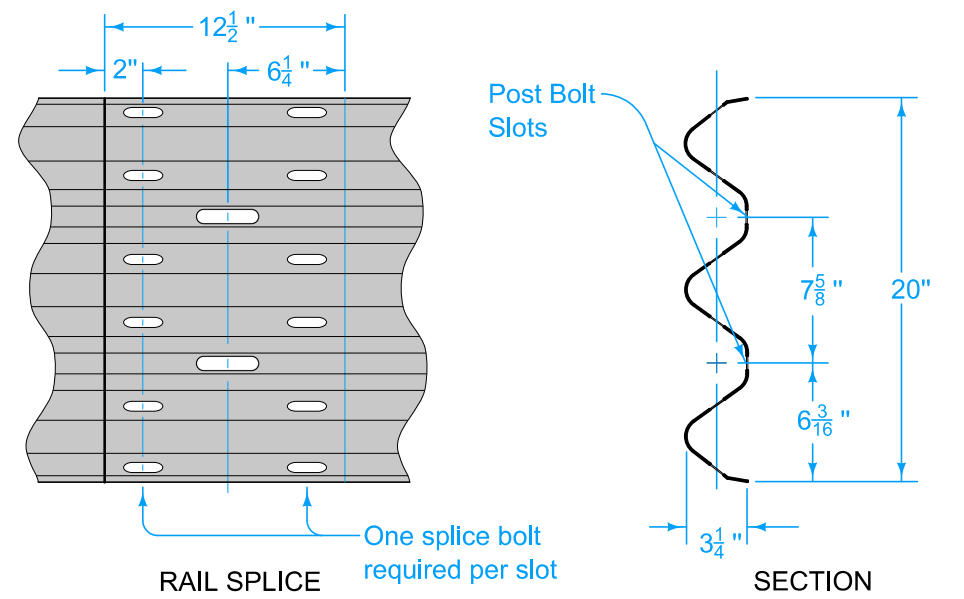

ASYMMETRICAL TRANSITION SECTION

 STANDARD ROAD PLAN	REVISION	
	7	04-15-25
	BA-200	
SHEET 4 of 5		
REVISIONS: Removed half post spacing, added quarter post spacing		
APPROVED BY DESIGN METHODS ENGINEER		
STEEL BEAM GUARDRAIL COMPONENTS		

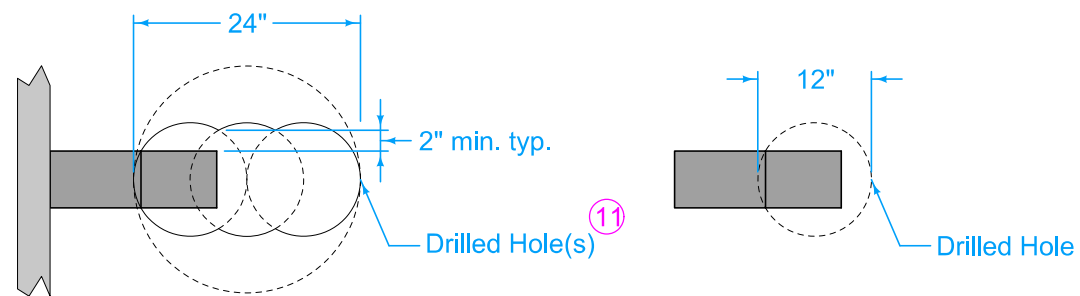
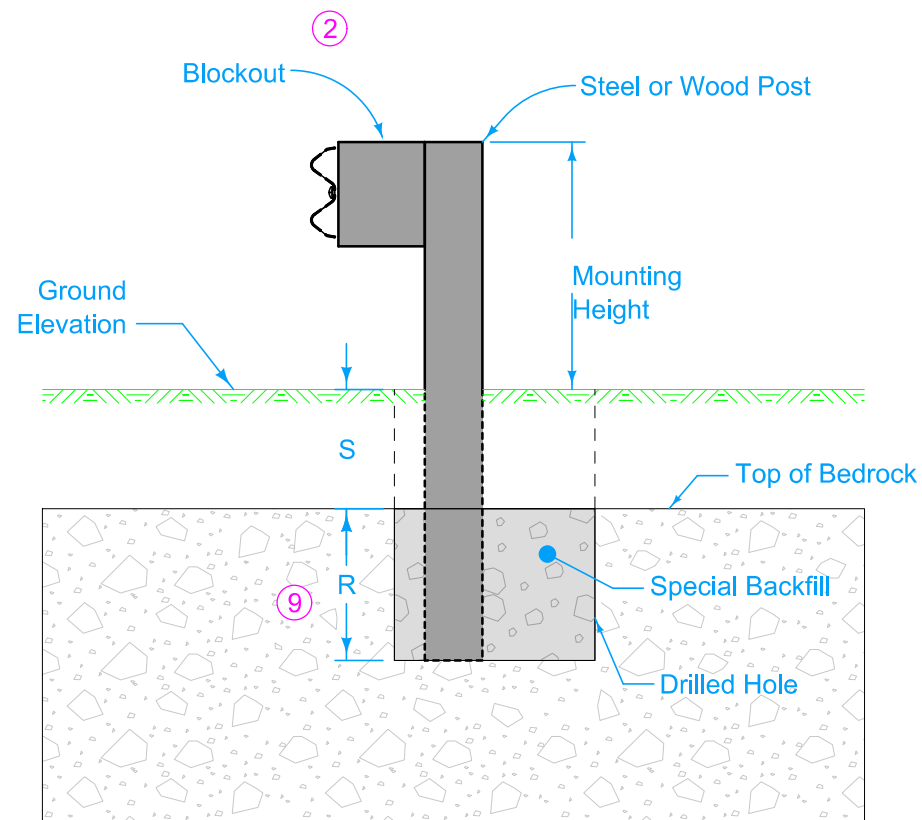

PLAN - CASE A

PLAN - CASE B

Post Embedment ⁹		
Case	Depth to Bedrock	Minimum Depth to Drill into Bedrock
A	S = 0" to 16"	R = 24"
B	S = 16" to 52"	R = Post Length - Mounting Height - S

POST INSTALLED IN BEDROCK

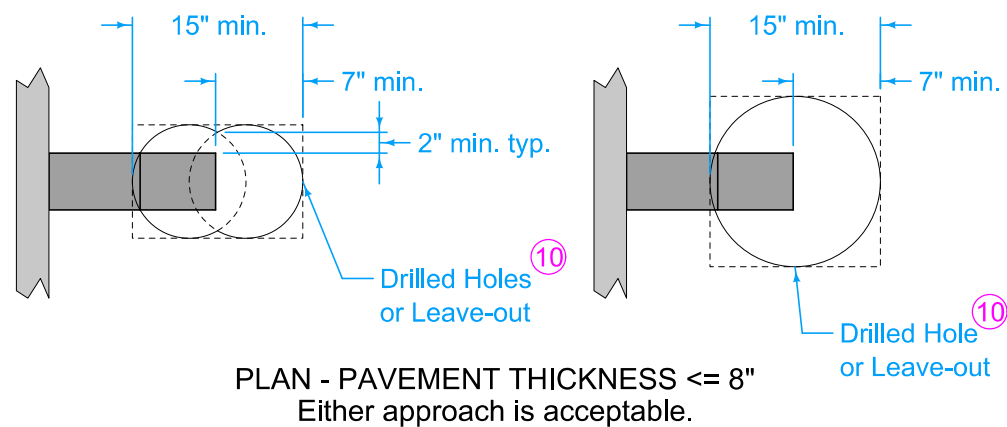
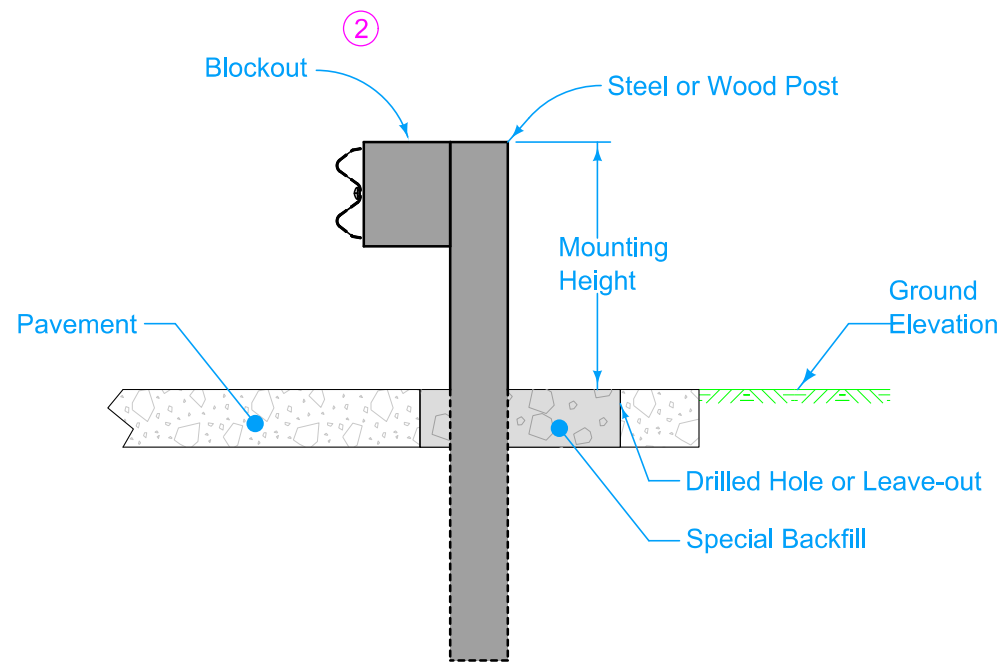

PLAN - PAVEMENT THICKNESS <= 8"
Either approach is acceptable.

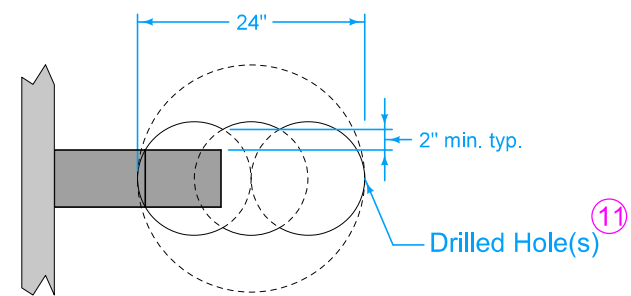

PLAN - PAVEMENT THICKNESS > 8"

Installation information applies to both wood and steel posts.

- ² Wood or composite only. Steel blockouts will not be allowed.
- ⁹ Post extends to bottom of hole in all cases. Trim top of post as required and treat with preservative according to Section 4161 of the Standard Specifications.
- ¹⁰ Use a 12 inch bit with two drills or a 15 inch bit with one drill. If placing post before paving, provide required leave-out area. If placing post after paving, drill or cut required area. Leave-out may be round or square.
- ¹¹ Use a 12 inch bit with three drills or a 24 inch bit with one drill.

	REVISION
	7 04-15-25
	BA-200
SHEET 5 of 5	

REVISIONS: Removed half post spacing, added quarter post spacing

APPROVED BY DESIGN METHODS ENGINEER

STEEL BEAM GUARDRAIL COMPONENTS