

Varies from 8 3/4" to 12 3/4"

ELEVATION

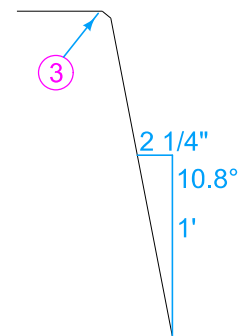

BARRIER FACE

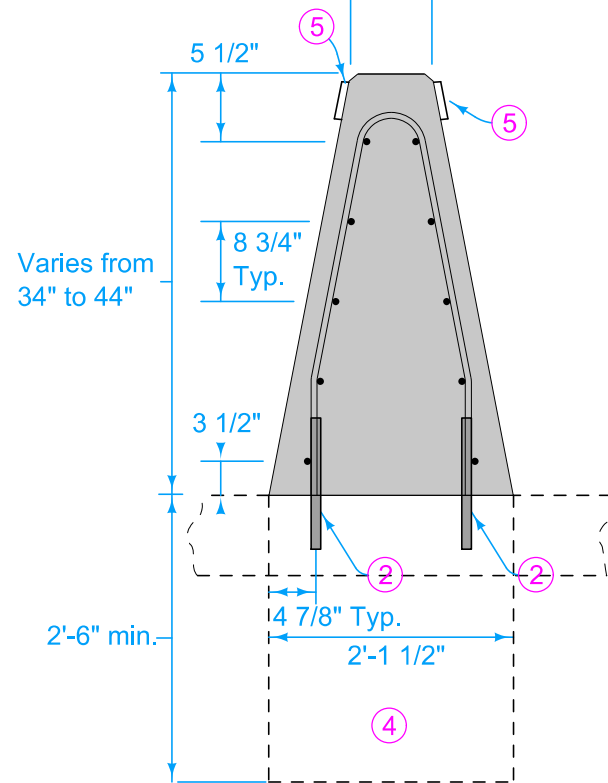

TYPICAL SECTION

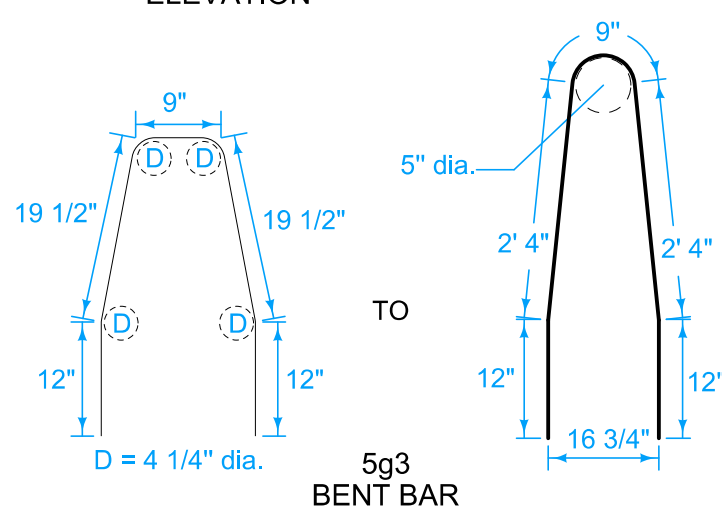

5g3 BENT BAR

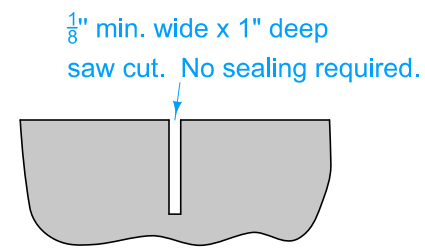

SAWED CONTRACTION JOINT  
Saw cut top and front face.  
Saw cut back if exposed.

Use Grade 60 epoxy-coated reinforcing bars. Provide 2 inches minimum cover. Anchor all reinforcement to prevent movement. Secure each section at the front, back, and at 3'-6" intervals using a method approved by the Engineer.

- ① Where abutting sections are placed as separate pours, a butt joint may be used. Extend longitudinal reinforcement into the abutting section a minimum of 3 feet.
- ② Use 1 inch diameter deformed dowel bars of sufficient length to ensure 6 inch minimum embedment in barrier and supporting surface. Install dowels either in supporting surface when placed, or in drilled holes using polymer grout complying with Materials I.M. 491.11 or hydraulic cement grout complying with Materials I.M. 491.13.
- ③ Fillet all exposed corners with a 3/4 inch dressed and beveled strip.
- ④ Construct concrete footing when barrier is not placed on concrete slab. Apply Article 2403.03 of the Standard Specifications, but the use of forms is optional. If forms are used, place backfill around the completed footing.
- ⑤ Place barrier markers at 100 foot increments in areas with non-continuous lighting, or 250 foot increments in areas with continuous lighting. Marker color to be the same as adjacent edge line.

CONCRETE QUANTITIES  
for one Transition Section  
1.9 cy

REINFORCING BAR LIST for one Transition Section					
Bar	Size	Number of Bars	Length	Weight (lbs.)	Spacing
5g3	5	11	*	122	12"
5f1	5	10	10' -0"	104	—

\* Varies from 5'-10" to 7'-5"

Possible Contract Item:  
Concrete Barrier, BA-115 or  
Concrete Barrier, BA-115 and Footing

Possible Tabulation:  
108-18B

 <b>STANDARD ROAD PLAN</b>	REVISION	
	New	04-21-26
<b>BA-115</b>		SHEET 1 of 1
REVISIONS: New		
 <small>APPROVED BY DESIGN METHODS ENGINEER</small>		
<b>34" TO 44" CONCRETE BARRIER TRANSITION SECTION (FULL SECTION)</b>		