

TYPICAL SECTION

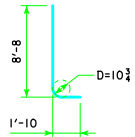

d2

NOTE: D = PIN DIAMETER. DIMENSIONS ARE OUT TO OUT.

NOTE: THE REINFORCING STEEL QUANTITY IS TO BE INCLUDED ON THE SUMMARY QUANTITIES SHEET IN THE PLAN.

NOTE: THE CONCRETE QUANTITY IS TO BE INCLUDED ON THE SUMMARY QUANTITIES SHEET IN THE PLAN.

NOTE: THE PILE TYPE IS TO BE INCLUDED ON THE SUMMARY QUANTITIES SHEET IN THE PLAN.

H IN FT.	CL - CL ABUT. BRG.	PILING (HP10x57)		FOOTING SIZE
		NO. & LAYOUT	① LRFD PU, STRENGTH I DES. LOAD (KIPS)	
20'1"-4	22B	143		4' x 10'-6 x 29'
213'-10	23B	144		
226'-4	24B	142		
243'-0	25B	144		
20'1"-4	22B	147		4' x 10'-6 x 29'
213'-10	24B	140		
226'-4	24B	145		
243'-0	25B	147		
20'1"-4	23B	145		4' x 10'-6 x 29'
213'-10	24B	142		
226'-4	25B	144		
243'-0	26B	144		
20'1"-4	24C	139		4' x 11' x 31'
213'-10	24C	144		
226'-4	25C	145		
243'-0	26C	145		
20'1"-4	24C	143		4' x 11' x 31'
213'-10	25C	143		
226'-4	26C	144		
243'-0	27A	145		

① NOTE: PU, STRENGTH I DESIGN LOAD (KIPS) IS NOT THE VALUE USED IN THE FIELD FOR DRIVING PILES.

FOOTING SIZE	REINFORCING STEEL (ONE FOOTING)			STRUCTURAL CONCRETE (CY)	
	BAR NO., SIZE & SPACING	LENGTH	WEIGHT (LB.)		
4' x 10'-6 x 29'	d2 58 - #10 AS SHOWN	10'-6	2621	4605	45.1
	f1 29 - #5 @ 1'-0	10'-2	308		
	f2 11 - #5 @ 1'-0	28'-8	329		
	g1 29 - #8 @ 1'-0	10'-2	787		
	g2 13 - #6 @ 0'-10	28'-8	560		
4' x 11' x 31'	d2 58 - #10 AS SHOWN	10'-6	2621	5404	50.5
	f1 31 - #5 @ 1'-0	10'-8	345		
	f2 11 - #5 @ 1'-0	30'-8	352		
	g1 33 - #8 @ 0'-11	10'-8	940		
	g2 14 - #8 @ 0'-9 1/2	30'-8	1146		

4'-0 x 10'-6 x 29'-0 FOR 22B & 23B

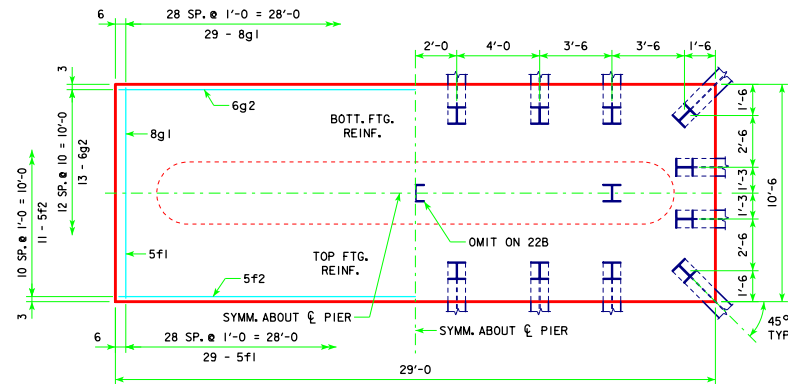

4'-0 x 10'-6 x 29'-0 FOR 24B, 25B & 26B

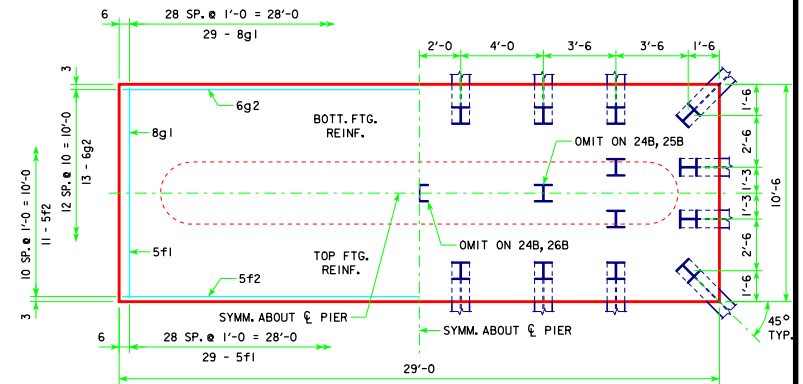

FOOTING NOTES:

THESE FOOTINGS ARE DESIGNED AND DETAILED TO BE USED WITH THE CAP AND COLUMN DETAILS OF THE TEE PIERS AS SHOWN ON SHEET H40-81-14.

BATTER PILES IN EXTERIOR ROWS 1/4 IN THE DIRECTION SHOWN.

STEEL PILING USED AS POINT BEARING SHALL HAVE A MINIMUM DISTANCE OF APPROXIMATELY 10 FEET FROM BOTTOM OF FOOTING TO TOP OF BEARING ROCK. THE PILE LAYOUTS ARE SUCH THAT THE DISTANCE CENTER TO CENTER OF ADJACENT PILING SHALL NOT EXCEED 8'-0.

PIER PILES SHALL BE DRIVEN TO VALUES SHOWN IN DESIGN PLANS.

4'-0 x 11'-0 x 31'-0 FOR 24C, 25C, 26C & 27A

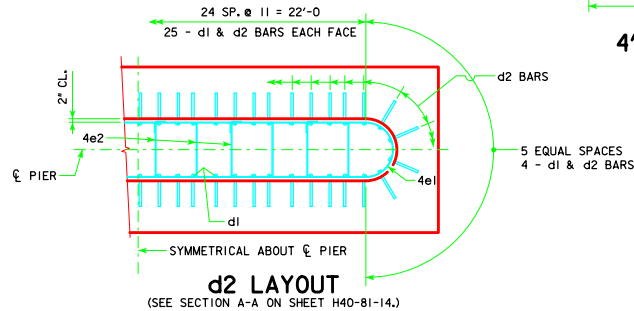
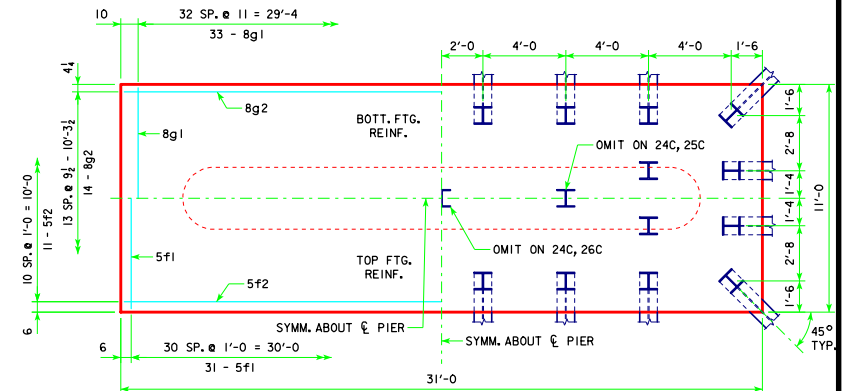

d2 LAYOUT
(SEE SECTION A-A ON SHEET H40-81-14.)

LATEST REVISION DATE
Thomas E. McQuinn
APPROVED BY BRIDGE ENGINEER

IOWADOT Highway Division

STANDARD DESIGN - 40' ROADWAY, THREE SPAN BRIDGE

PRETENSIONED PRESTRESSED CONCRETE BEAM BRIDGES

SEPTEMBER, 2014

TEE PIER-HP10x57 SRL-1 STEEL PILE FOOTINGS

45° SKEW - H=25' TO 40'

H40-84-14