

RECTANGULAR

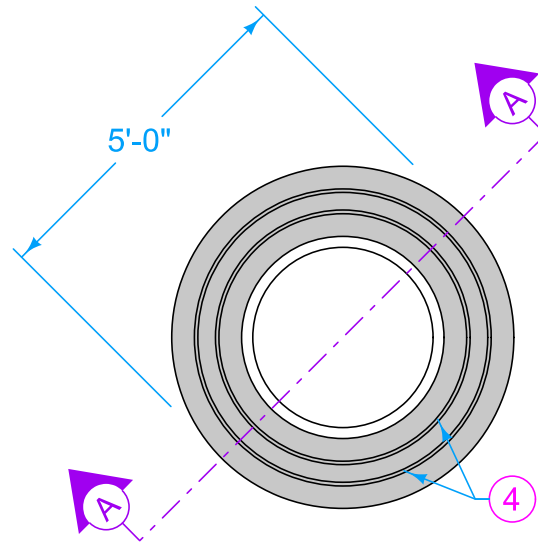

CIRCULAR

Construct boxout with Class C concrete or match pavement class. Minimum 2 inches clear on reinforcement. Minimum 12 inches of concrete between outside of casting and nearest joint. Center casting within boxout area if possible.

- ① 4 foot 8 inch (typ.) #4 bar. Place at mid-slab.
- ② If boxout is constructed prior to placement of HMA overlay or final lift of HMA pavement, boxout may be constructed low, with a 'B' joint in place of the 'E' joint, and then final lift or overlay placed.
- ③ Apply tack coat.
- ④ #4 hoops (variable length). Place at mid-slab.

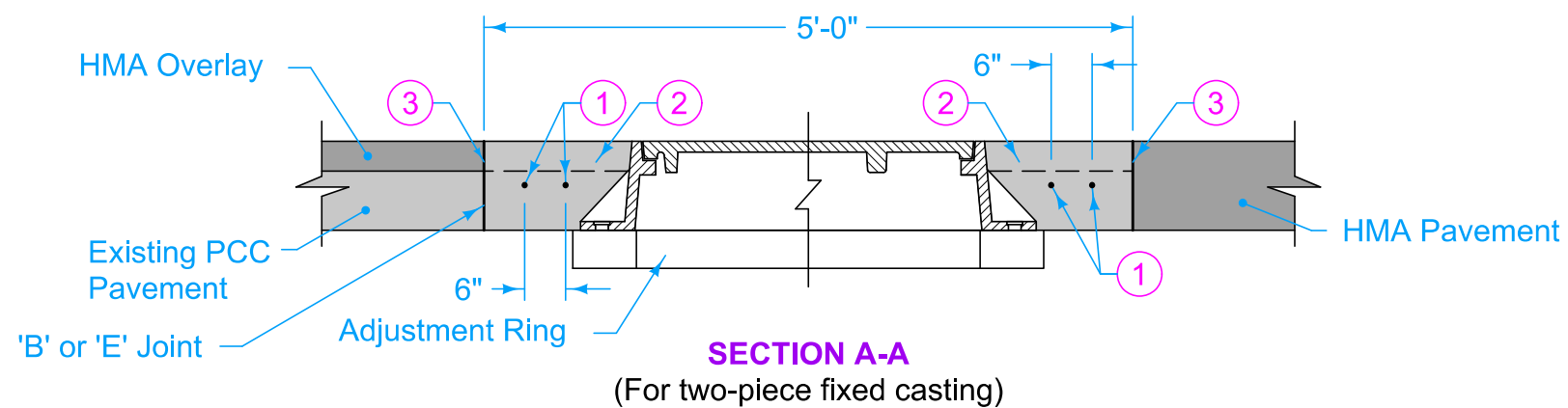
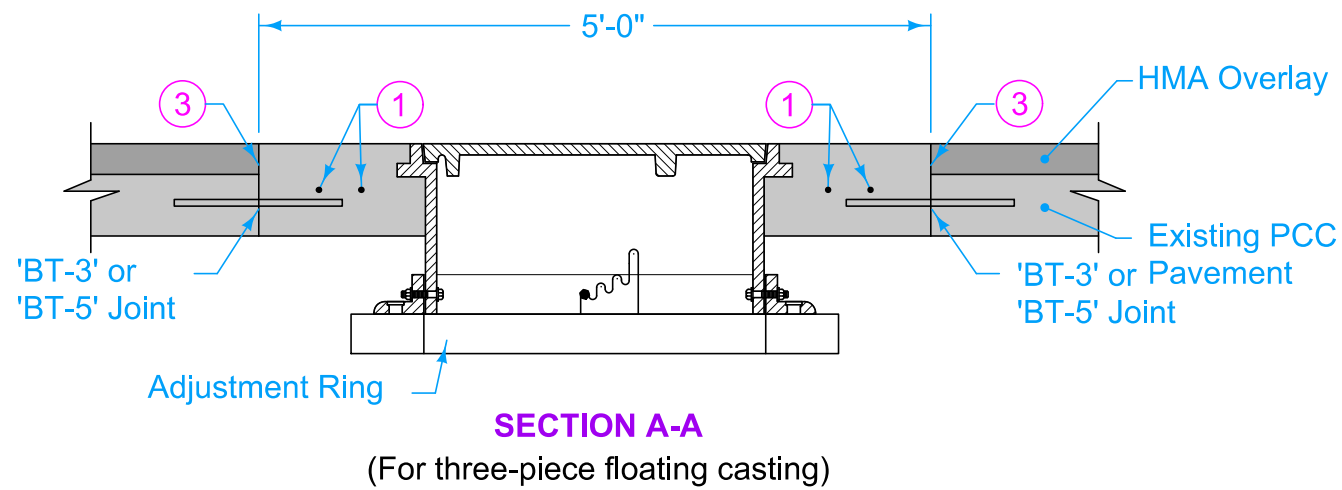

SUDAS	IOWA DOT	REVISION
		2 04-19-22
FIGURE 7020.201	STANDARD ROAD PLAN	PV-201
		SHEET 1 of 1

REVISIONS: Added note 12 inch minimum around casting.

Paul D. Wrigand
 SUDAS DIRECTOR

Stuart Miller
 DESIGN METHODS ENGINEER

**MANHOLE BOXOUTS IN
HMA PAVEMENT AND
HMA OVERLAYS**