

All plate and edge armor steel to be ASTM A 36, galvanized after fabrication.

Remove cover plate before constructing concrete barrier.

Cast frames into intake top so tops of grates are 1/4" below Form Grade Elevation. Bolt intake frames together on both sides with four 1/2" x 4" bolts.

For joint details, refer to PV-1.



- ① Trowel smooth and place two layers of 30-pound roofing felt to prevent bond.
- ② Vary slope of top to match elevation of adjacent pavement.
- ③ 12-inch minimum wall height above all pipes.

Possible Contract Item:

Barrier Intake, SW-549

Possible Tabulation:

104-5B

 Iowa Department of Transportation	REVISION
	2 10-19-10
<b>STANDARD ROAD PLAN</b>	<b>SW-549</b>
SHEET 1 of 5	
REVISIONS: Renumbered circle notes. Removed opening through barrier.	
 APPROVED BY DESIGN METHODS ENGINEER	
<b>SINGLE-GRATE BARRIER INTAKE, RECTANGULAR</b>	

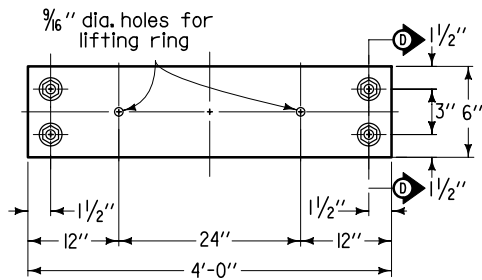

PLAN

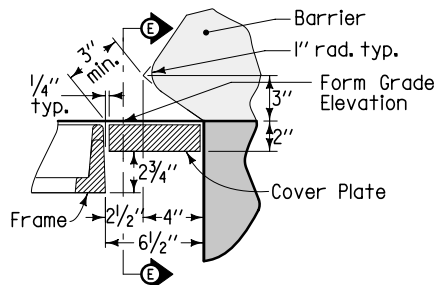

SECTION A-A  
(LID)

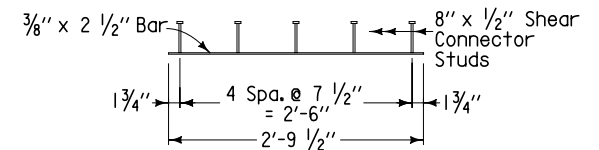

FRAME RING  
(2 required)

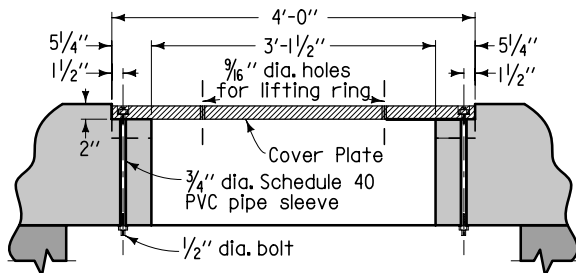

SECTION E-E

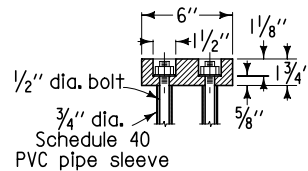

SECTION D-D

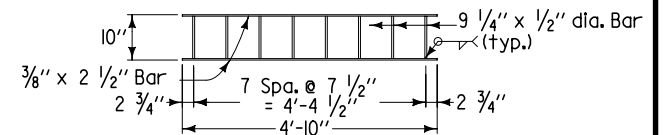

WALL  
(4 required)

EDGE ARMOR

COVER PLATE

<p>Iowa Department of Transportation</p> <p><b>STANDARD ROAD PLAN</b></p> <p>REVISIONS: Renumbered circle notes. Removed opening through barrier.</p>	<p>REVISION</p> <p>2 10-19-10</p>	
	<p><b>SW-549</b></p> <p>SHEET 2 of 5</p>	

*Deanna Maifeld*  
APPROVED BY DESIGN METHODS ENGINEER

**SINGLE-GRATE BARRIER INTAKE,  
RECTANGULAR**

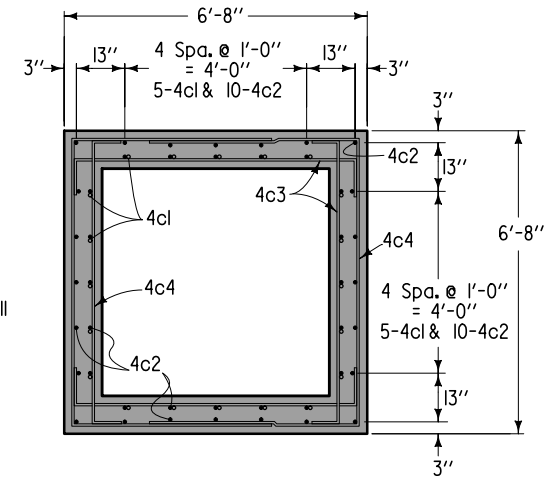
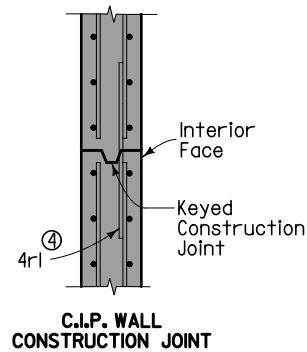
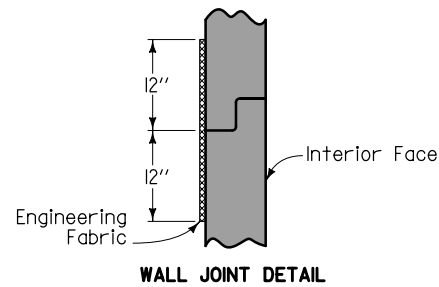
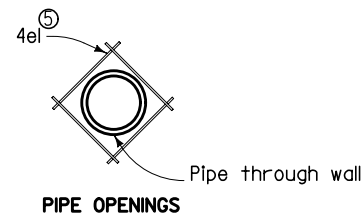
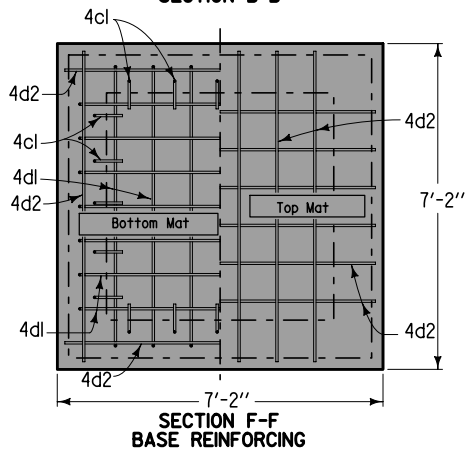
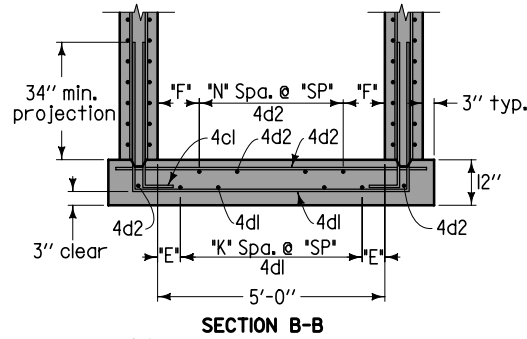
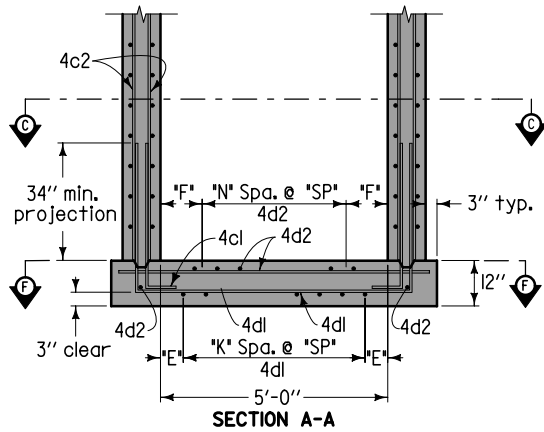
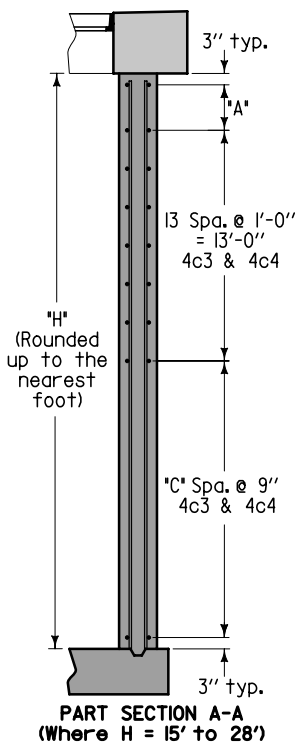
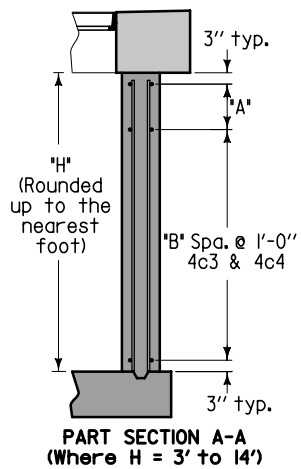

- ④ Install 4r1 x 3'-0" dowelbars at 12-inch spacing at all wall joints. Twenty-four 4r1 bars required per joint, total weight = 48 lbs.
- ⑤ 4el bar length to be pipe diameter plus 12 inches. Place 4el bar inside of vertical reinforcing. Shift main reinforcing bars as required for pipe entrance. Field cut bars to maintain 3-inch clearance from bottom and 2-inch clearance from face of walls. Four 4el bars required per pipe entrance.

 Iowa Department of Transportation	REVISION
	2 10-19-10
<b>STANDARD ROAD PLAN</b>	<b>SW-549</b>
SHEET 3 of 5	
REVISIONS: Renumbered circle notes. Removed opening through barrier.	
<i>Deanna Maifeld</i> APPROVED BY DESIGN METHODS ENGINEER	
<b>SINGLE-GRATE BARRIER INTAKE, RECTANGULAR</b>	

**WALLS**

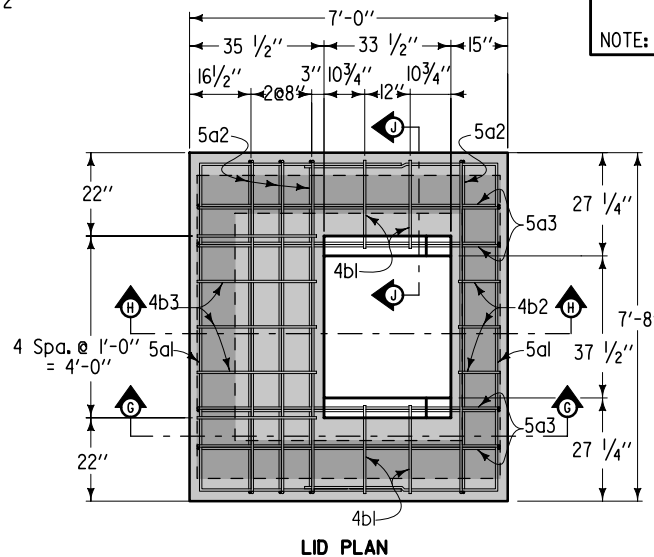
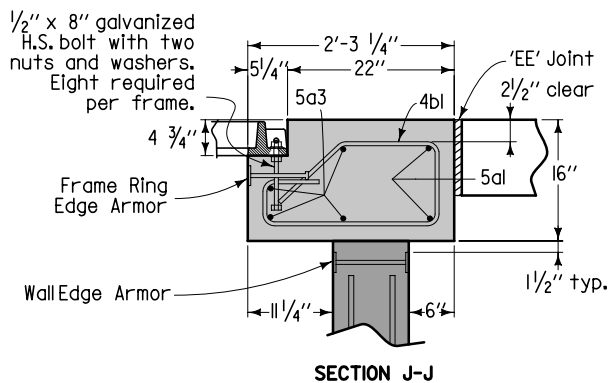
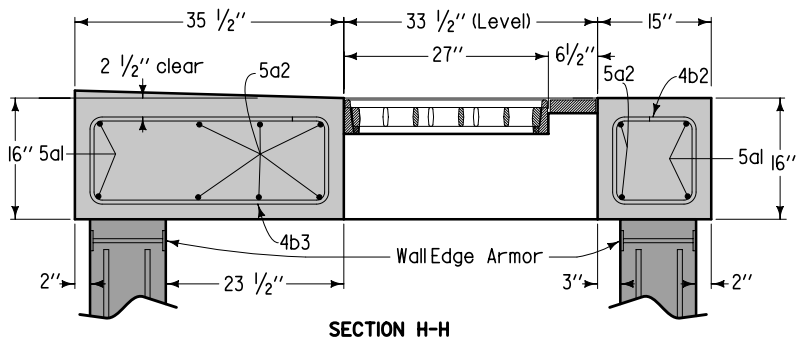
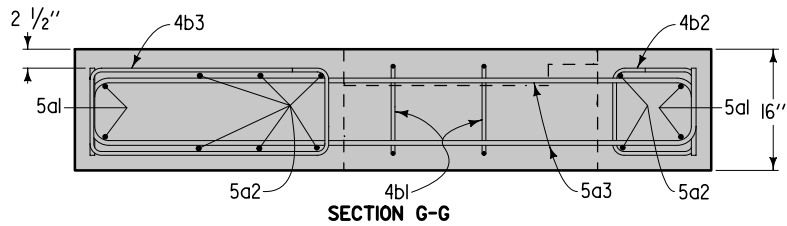

**LID REINFORCING BAR LIST**  
**EPOXY-COATED**

BAR	LOCATION	SHAPE	NO.	LENGTH	WEIGHT (lb.)
5a1	Lid, Exterior, Edge	[U-shape]	4	16'-5	68
5a2	Lid, Interior, Longitudinal	[U-shape]	8	9'-0	75
5a3	Lid, Interior, Transverse	[U-shape]	8	8'-4	70
4b1	Lid Hoop	[C-shape]	4	5'-11	16
4b2	Lid Hoop	[C-shape]	3	4'-7	9
4b3	Lid Hoop	[C-shape]	5	8'-0	27
EPOXY COATED REINFORCING STEEL - TOTAL					265

**LID BENT BAR DETAILS**

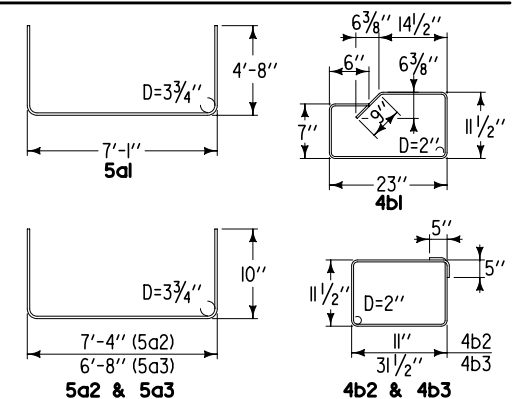

NOTE: ALL DIMENSIONS SHOWN OUT TO OUT. D = PIN DIAMETER

Iowa Department of Transportation  
**STANDARD ROAD PLAN**  
REVISIONS: Renumbered circle notes. Removed opening through barrier.

REVISION	2	10-19-10
<b>SW-549</b>		
SHEET 4 of 5		

Deanna Maifeld  
APPROVED BY DESIGN METHODS ENGINEER

**SINGLE-GRATE BARRIER INTAKE, RECTANGULAR**

VARIABLE DIMENSIONS AND QUANTITIES

Dimensions				Bar List												Quantities												
⑥ "H" (Ft.)	⑦ "A" (In.)	"E" (In.)	"F" (In.)	4c1		4c2		⑧ 4c3		⑧ 4c4		4d1		4d2		Concrete - Cu. Yds.				Steel								
				NO.	L	NO.	L	No. of Spaces		No. of Spaces		NO.	L	SP	"K"	NO.	L	SP	"N"	NO.	L	BASE	LID	WALLS	TOTAL	TOTAL LBS.		
3	6	3"	7½"	20	4'-3"	--	--	2	--	16	7'-8"	2	--	8	15'-0"	9"	6	14	13'-5"	9"	5	16	6'-10"	1.9	2.2	2.2	6.3	682
4	6	3"	7½"	20	4'-3"	44	3'-10"	3	--	20	7'-8"	3	--	10	15'-0"	9"	6	14	13'-5"	9"	5	16	6'-10"	1.9	2.2	2.9	7.0	835
5	6	3"	7½"	20	4'-3"	44	4'-10"	4	--	24	7'-8"	4	--	12	15'-0"	9"	6	14	13'-5"	9"	5	16	6'-10"	1.9	2.2	3.6	7.7	905
6	6	3"	7½"	20	4'-3"	44	5'-10"	5	--	28	7'-8"	5	--	14	15'-0"	9"	6	14	13'-5"	9"	5	16	6'-10"	1.9	2.2	4.3	8.4	974
7	6	3"	7½"	20	4'-3"	44	6'-10"	6	--	32	7'-8"	6	--	16	15'-0"	9"	6	14	13'-5"	9"	5	16	6'-10"	1.9	2.2	5.0	9.1	1,045
8	6	3"	7½"	20	4'-3"	44	7'-10"	7	--	36	7'-8"	7	--	18	15'-0"	9"	6	14	13'-5"	9"	5	16	6'-10"	1.9	2.2	5.8	9.9	1,114
9	6	3"	7½"	20	4'-3"	44	8'-10"	8	--	40	7'-8"	8	--	20	15'-0"	9"	6	14	13'-5"	9"	5	16	6'-10"	1.9	2.2	6.5	10.6	1,185
10	6	3"	7½"	20	4'-3"	44	9'-10"	9	--	44	7'-8"	9	--	22	15'-0"	9"	6	14	13'-5"	9"	5	16	6'-10"	1.9	2.2	7.2	11.3	1,254
11	6	2"	6"	20	4'-3"	44	10'-10"	10	--	48	7'-8"	10	--	24	15'-0"	8"	7	16	13'-5"	8"	6	18	6'-10"	1.9	2.2	7.9	12.0	1,351
12	6	2"	6"	20	4'-3"	44	11'-10"	11	--	52	7'-8"	11	--	26	15'-0"	8"	7	16	13'-5"	8"	6	18	6'-10"	1.9	2.2	8.6	12.7	1,422
13	6	2"	6"	20	4'-3"	44	12'-10"	12	--	56	7'-8"	12	--	28	15'-0"	8"	7	16	13'-5"	8"	6	18	6'-10"	1.9	2.2	9.4	13.5	1,492
14	6	2"	6"	20	4'-3"	44	13'-10"	13	--	60	7'-8"	13	--	30	15'-0"	8"	7	16	13'-5"	8"	6	18	6'-10"	1.9	2.2	10.1	14.2	1,562
15	9	2"	6"	20	4'-3"	44	14'-10"	13	1	64	7'-8"	13	1	32	15'-0"	8"	7	16	13'-5"	8"	6	18	6'-10"	1.9	2.2	10.8	14.9	1,632
16	12	2"	6"	20	4'-3"	44	15'-10"	13	2	68	7'-8"	13	2	34	15'-0"	8"	7	16	13'-5"	8"	6	18	6'-10"	1.9	2.2	11.5	15.6	1,701
17	6	2"	6"	20	4'-3"	44	16'-10"	13	4	76	7'-8"	13	4	38	15'-0"	8"	7	16	13'-5"	8"	6	18	6'-10"	1.9	2.2	12.2	16.3	1,812
18	9	2"	6"	20	4'-3"	44	17'-10"	13	5	80	7'-8"	13	5	40	15'-0"	8"	7	16	13'-5"	8"	6	18	6'-10"	1.9	2.2	13.0	17.1	1,882
19	12	2"	6"	20	4'-3"	44	18'-10"	13	6	84	7'-8"	13	6	42	15'-0"	8"	7	16	13'-5"	8"	6	18	6'-10"	1.9	2.2	13.7	17.8	1,952
20	6	2"	6"	20	4'-3"	44	19'-10"	13	8	92	7'-8"	13	8	46	15'-0"	8"	7	16	13'-5"	8"	6	18	6'-10"	1.9	2.2	14.4	18.5	2,062
21	9	2"	6"	20	4'-3"	44	20'-10"	13	9	96	7'-8"	13	9	48	15'-0"	8"	7	16	13'-5"	8"	6	18	6'-10"	1.9	2.2	15.1	19.2	2,132
22	12	2"	6"	20	4'-3"	44	21'-10"	13	10	100	7'-8"	13	10	50	15'-0"	8"	7	16	13'-5"	8"	6	18	6'-10"	1.9	2.2	15.8	19.9	2,202
23	6	2"	6"	20	4'-3"	44	22'-10"	13	12	108	7'-8"	13	12	54	15'-0"	8"	7	16	13'-5"	8"	6	18	6'-10"	1.9	2.2	16.6	20.7	2,312
24	9	2"	5½"	20	4'-3"	44	23'-10"	13	13	112	7'-8"	13	13	56	15'-0"	7"	8	18	13'-5"	7"	7	20	6'-10"	1.9	2.2	17.3	21.4	2,410
25	12	2"	5½"	20	4'-3"	44	24'-10"	13	14	116	7'-8"	13	14	58	15'-0"	7"	8	18	13'-5"	7"	7	20	6'-10"	1.9	2.2	18.0	22.1	2,479
26	6	2"	5½"	20	4'-3"	44	25'-10"	13	16	124	7'-8"	13	16	62	15'-0"	7"	8	18	13'-5"	7"	7	20	6'-10"	1.9	2.2	18.7	22.8	2,589
27	9	2"	5½"	20	4'-3"	44	26'-10"	13	17	128	7'-8"	13	17	64	15'-0"	7"	8	18	13'-5"	7"	7	20	6'-10"	1.9	2.2	19.4	23.5	2,660
28	12	2"	5½"	20	4'-3"	44	27'-10"	13	18	132	7'-8"	13	18	66	15'-0"	7"	8	18	13'-5"	7"	7	20	6'-10"	1.9	2.2	20.2	24.3	2,729

- ⑥ A = First bar spacing at top of wall. Minimum spacing is 3 inches. Maximum spacing is 12 inches. Adjust as necessary.
- ⑦ See Section A-A on sheet 2 for spacing.
- ⑧ Quantity includes 265 lbs. for lid.

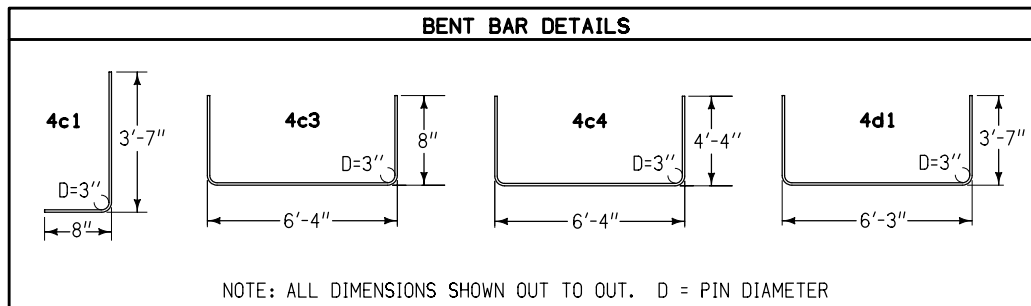

REINFORCEMENT

<p>Iowa Department of Transportation</p> <p><b>STANDARD ROAD PLAN</b></p> <p>REVISIONS: Renumbered circle notes. Removed opening through barrier.</p> <p style="text-align: right;"><i>Deanna Maifeld</i> APPROVED BY DESIGN METHODS ENGINEER</p>	REVISION 2 10-19-10
	<p><b>SW-549</b></p> <p>SHEET 5 of 5</p>
	<p><b>SINGLE-GRATE BARRIER INTAKE, RECTANGULAR</b></p>