

PLAN (SHALLOW)

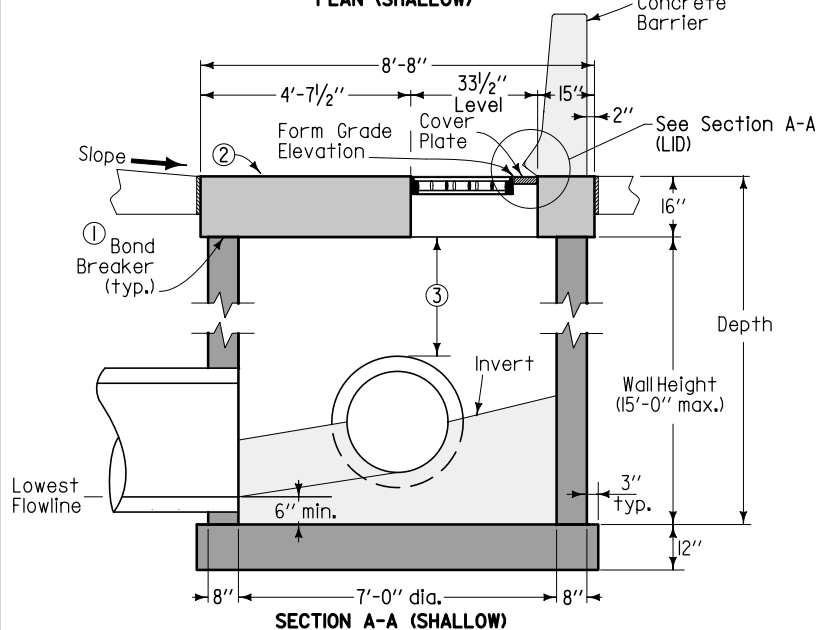

SECTION A-A (SHALLOW)

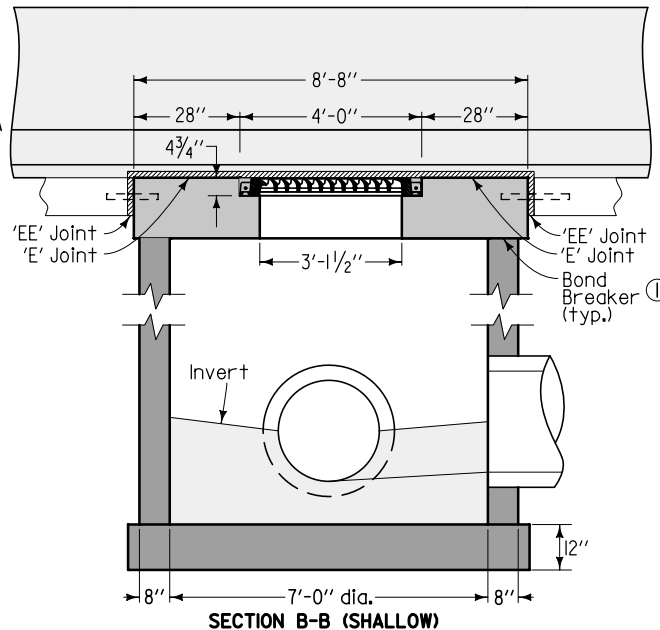

SECTION B-B (SHALLOW)

All plate and edge armor steel to be ASTM A 36, galvanized after fabrication.

Remove cover plate before constructing concrete barrier.

Cast frames into intake top so tops of grates are 1/4" below Form Grade Elevation. Bolt intake frames together on both sides with four 1/2" x 4" bolts.

For joint details, refer to PV-1.

- ① Trowel smooth and place two layers of 30-pound roofing felt to prevent bond.
- ② Vary slope of top to match elevation of adjacent pavement.
- ③ 12-inch minimum above all pipes.

Shallow circular intake H = 3'-0" to 15'-0" 7' barrel diameter
Deep circular option: H = 15'-0" to 28'-0" 4' and 7' barrel diameters

Possible Contract Item:  
Barrier Intake, SW-548

Possible Tabulation:  
104-5B

 Iowa Department of Transportation <b>STANDARD ROAD PLAN</b>	REVISION 2 10-19-10
	<b>SW-548</b>
	SHEET 1 of 6
<small>REVISIONS: Removed opening through barrier. Renumbered circle notes.</small> <i>Deanna Maifeld</i> <small>APPROVED BY DESIGN METHODS ENGINEER</small>	
<b>SINGLE-GRATE BARRIER INTAKE, CIRCULAR</b>	



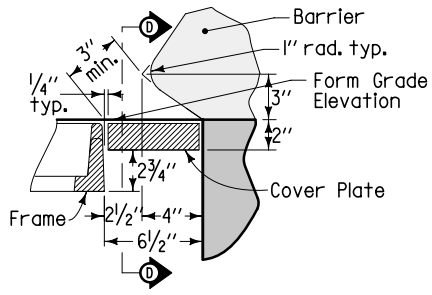
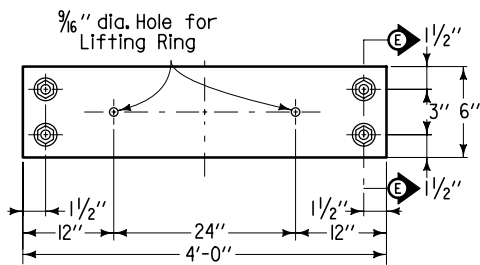

SECTION A-A (LID)

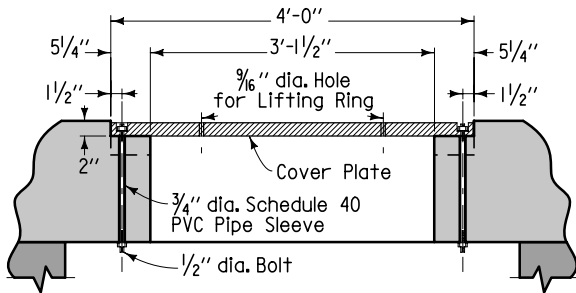

SECTION D-D

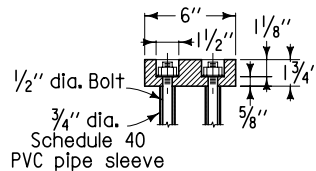

SECTION E-E

COVER PLATE

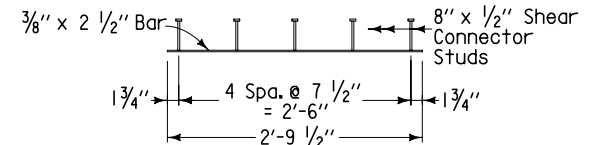

FRAME RING (2 required)

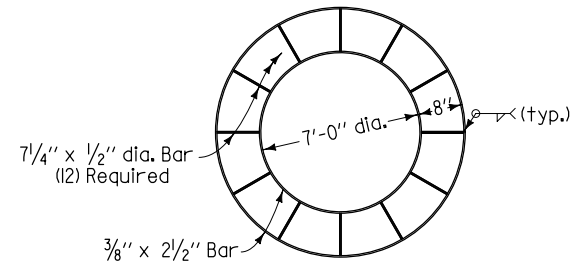

WALL (SHALLOW)

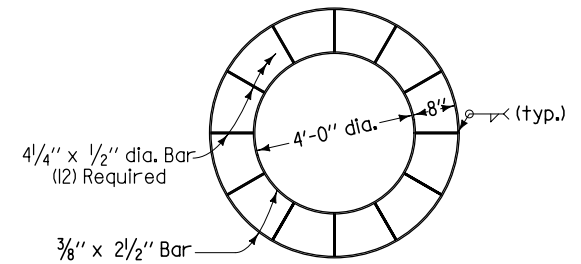

WALL (DEEP)

EDGE ARMOR

<p>Iowa Department of Transportation</p> <p><b>STANDARD ROAD PLAN</b></p> <p>REVISIONS: Removed opening through barrier. Renumbered circle notes.</p> <p><i>Deanna Maifeld</i> APPROVED BY DESIGN METHODS ENGINEER</p> <p><b>SINGLE-GRATE BARRIER INTAKE, CIRCULAR</b></p>	<p>REVISION</p> <p>2 10-19-10</p>
	<p><b>SW-548</b></p> <p>SHEET 3 of 6</p>

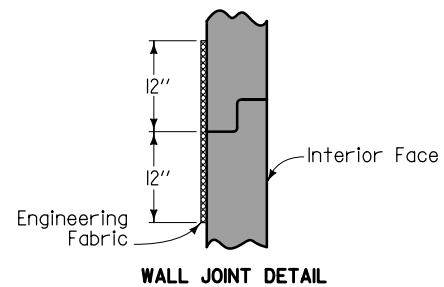
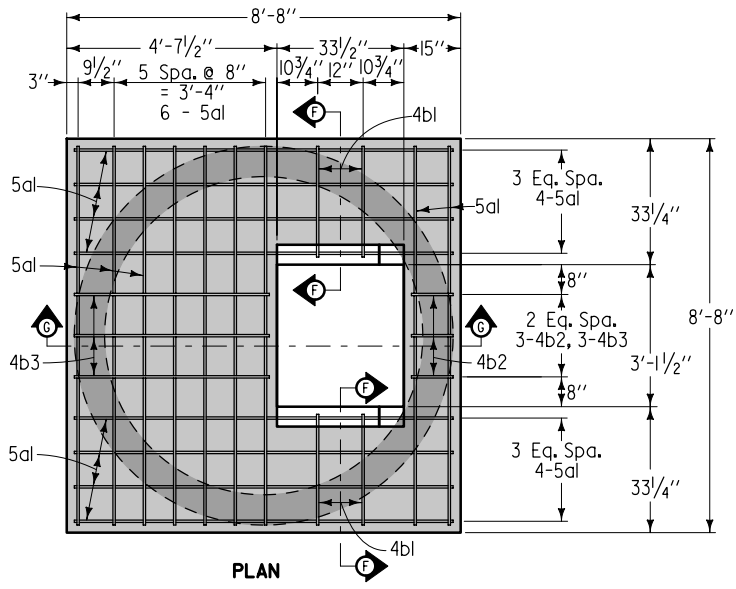

LID REINFORCING BAR LIST						
EPOXY-COATED						
BAR	LOCATION	SHAPE	NO.	LENGTH	WEIGHT	
5al	Lid, Longitudinal & Transverse		34	8'-4"	296	
4bl	Lid Hoop		4	6'-11"	18	
4b2	Lid Hoop		3	4'-7"	9	
4b3	Lid Hoop		3	11'-4"	23	
EPOXY COATED REINFORCING STEEL - TOTAL						346

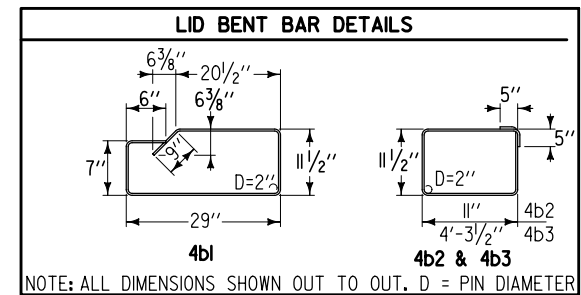

LID QUANTITY SUMMARY (SHALLOW)		
Concrete		3.2 CY
Epoxy Coated Reinforcing Steel		346 LB
• Based on Minimum thickness = 16"		

Maximum Pipe Diameter for Pipes at:		
90° Separation	180° Separation	
36	48	

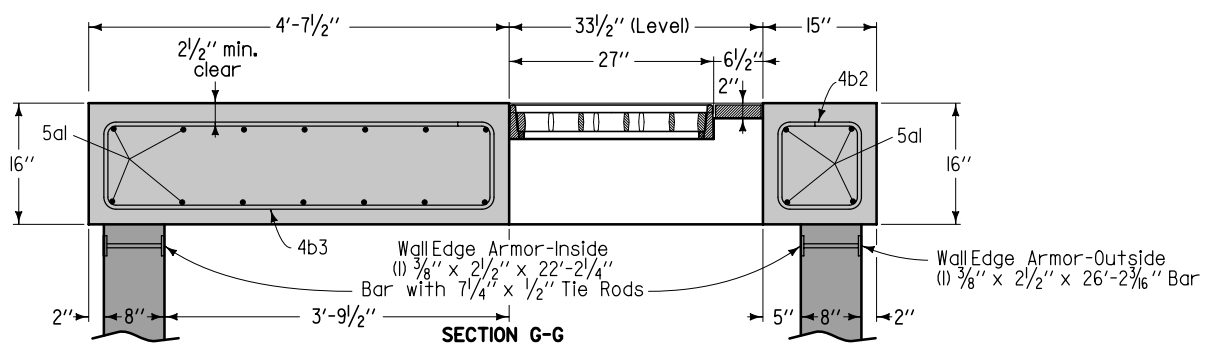
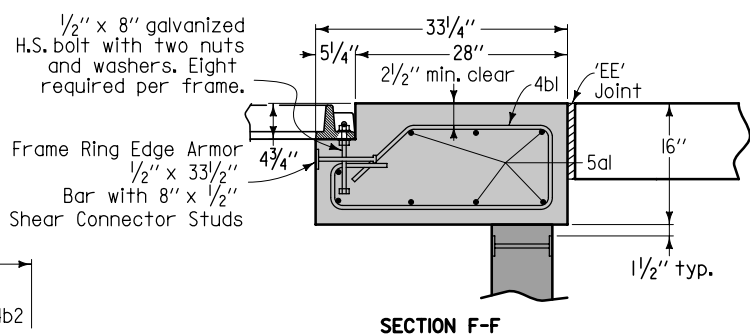

Iowa Department of Transportation

**STANDARD ROAD PLAN**

REVISIONS: Removed opening through barrier. Renumbered circle notes.

Deanna Maifeld  
APPROVED BY DESIGN METHODS ENGINEER

REVISION	2	10-19-10
<b>SW-548</b>		
SHEET 4 of 6		

**SINGLE-GRATE BARRIER INTAKE, CIRCULAR**

LID (SHALLOW)

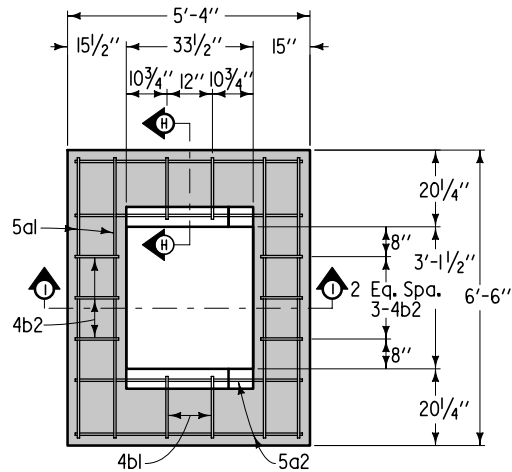

PLAN

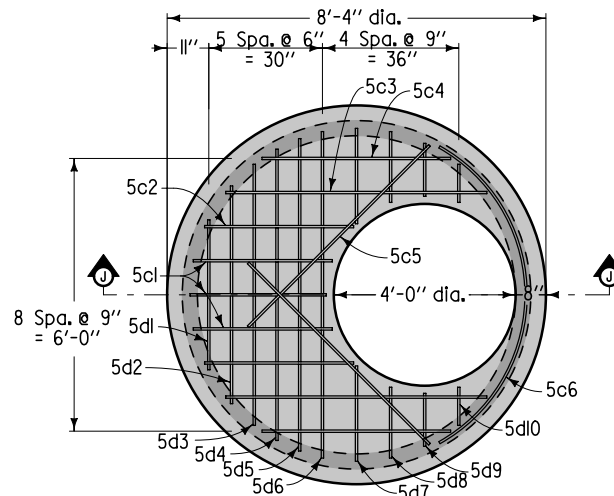

SECTION C-C  
INTERMEDIATE LID

LID REINFORCING BAR LIST					
EPOXY-COATED					
BAR	LOCATION	SHAPE	NO.	LENGTH	WEIGHT
5a1	Lid, Longitudinal	—	8	6'-2"	51
5a2	Lid, Transverse	—	8	5'-0"	42
4b1	Lid Hoop	⊠	4	4'-9"	13
4b2	Lid Hoop	⊠	6	4'-7"	18
5c1	Intermediate Lid	—	3	3'-0"	9
5c2	Intermediate Lid	—	2	3'-3"	7
5c3	Intermediate Lid	—	2	5'-9"	12
5c4	Intermediate Lid	—	2	4'-2"	9
5c5	Intermediate Lid	—	2	5'-8"	12
5c6	Intermediate Lid	—	1	8'-2"	9
5d1	Intermediate Lid	—	1	3'-5"	4
5d2	Intermediate Lid	—	1	4'-10"	5
5d3	Intermediate Lid	—	1	5'-9"	6
5d4	Intermediate Lid	—	1	6'-5"	7
5d5	Intermediate Lid	—	1	6'-10"	7
5d6	Intermediate Lid	—	1	7'-2"	7
5d7	Intermediate Lid	—	2	2'-1"	4
5d8	Intermediate Lid	—	2	1'-6"	3
5d9	Intermediate Lid	—	2	1'-2"	2
5d10	Intermediate Lid	—	2	0'-11"	2
EPOXY COATED REINFORCING STEEL - TOTAL					229

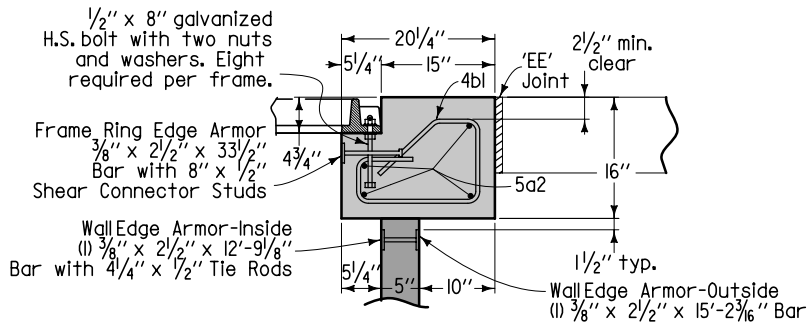

SECTION H-H

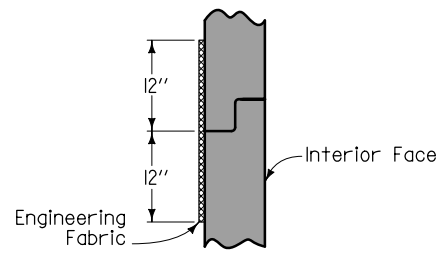

WALL JOINT DETAIL

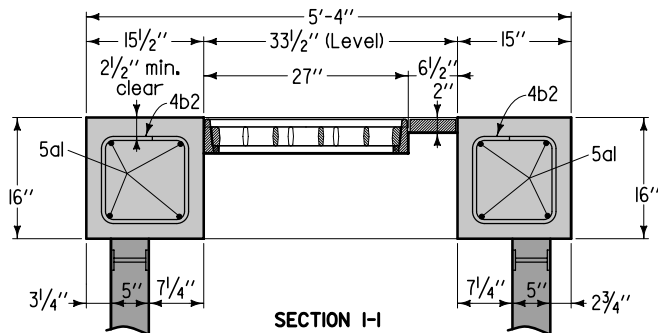

SECTION I-I

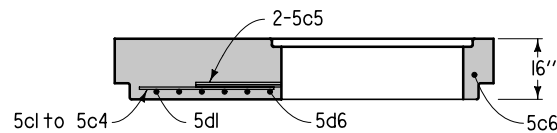

LID (DEEP)

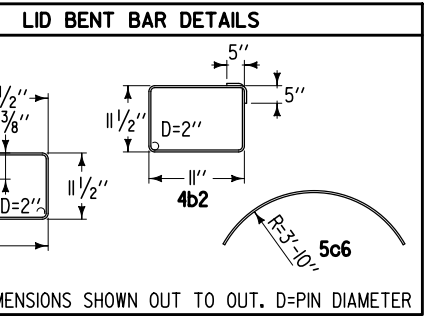

NOTE: ALL DIMENSIONS SHOWN OUT TO OUT. D=PIN DIAMETER

LID QUANTITY SUMMARY (DEEP)		
Concrete - Lid		L2 CY
Concrete - Intermediate Lid		2J CY
Epoxy Coated Reinforcing Steel		229 LB

**Iowa Department of Transportation**

**STANDARD ROAD PLAN**

REVISIONS: Removed opening through barrier. Renumbered circle notes.

*Deanna Maifeld*  
APPROVED BY DESIGN METHODS ENGINEER

REVISION	2	10-19-10
<b>SW-548</b>		
SHEET 5 of 6		

**SINGLE-GRATE BARRIER INTAKE, CIRCULAR**

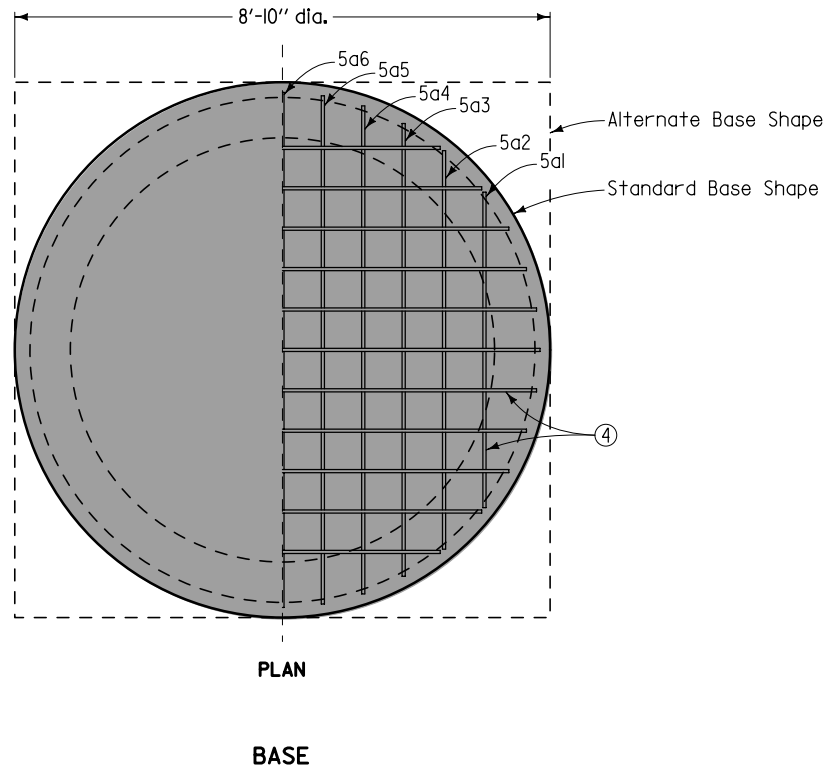
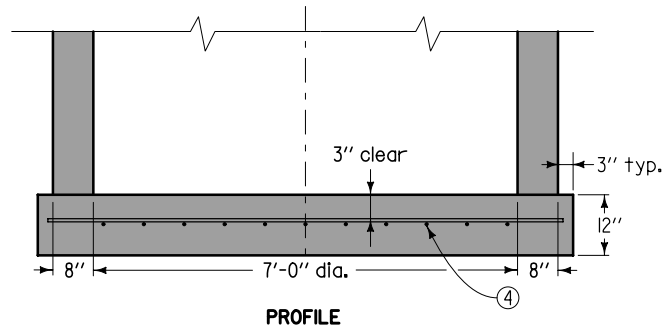

BASE REINFORCING BAR LIST					
EPOXY-COATED					
BAR	LOCATION	SHAPE	NO.	LENGTH	WEIGHT
5a1	Base, Longit. & Transverse	—	4	5'-3"	22
5a2	Base, Longit. & Transverse	—	4	6'-7"	27
5a3	Base, Longit. & Transverse	—	4	7'-6"	31
5a4	Base, Longit. & Transverse	—	4	8'-0"	33
5a5	Base, Longit. & Transverse	—	4	8'-4"	35
5a6	Base, Longit. & Transverse	—	2	8'-6"	18
EPOXY COATED REINFORCING STEEL - TOTAL					166

BASE QUANTITY SUMMARY	
Concrete	2.3 CY
Epoxy Coated Reinforcing Steel	166 LB

• Based on Standard Base Shape

- ④ #5 at 8-inch centers each direction or equivalent welded wire fabric.
- ⑤ 4elbar length to be pipe diameter plus 12 inches. Place 4elabr inside of vertical reinforcing. Shift main reinforcing bars as required for pipe entrance. Filed cut bars to maintain 3-inch clearance from bottom. Maintain 2-inch clearance from face of walls. Four 4elbars required per pipe entrance.

	REVISION
	2 10-19-10
<b>STANDARD ROAD PLAN</b>	<b>SW-548</b>
SHEET 6 of 6	
REVISIONS: Removed opening through barrier. Renumbered circle notes.	
 APPROVED BY DESIGN METHODS ENGINEER	
<b>SINGLE-GRATE BARRIER INTAKE, CIRCULAR</b>	