

POST DATA	
Post Size	Stub Length
W 6 x 9	2'-6"
W 6 x 12	
W 6 x 15	
W 8 x 18	
W 8 x 21	3'-0"
W 10 x 22	
W 10 x 26	
W 12 x 26	

Post Size	Bolt Size & Torque	BREAKAWAY BASE DATA									
		(A)	(B)	(C)	(D)	(E)	(T1)	(T2)	(W)	(R)	
W 6 x 9	5/8" dia. x 2 3/4" Torque = 37.50 ft. lbs.	5"	2"	1 1/4"	2 3/4"	1 1/8"	3"	1 1/2"	1"	1 1/4"	11 3/2"
W 6 x 12		3/4" dia. x 3 1/4" Torque = 62.50 ft. lbs.	6"	2 1/4"	1 3/8"	3 1/2"	1 1/4"	1"	3/4"	5 1/16"	13 3/32"
W 6 x 15											
W 8 x 18											
W 8 x 21											
W 10 x 22											
W 10 x 26											
W 12 x 26											

Place signpost by installing shims. Furnish two shims each of 0.012" and 0.032" thickness (total of 4 per post). Shims to be brass stock or strip conforming to ASTM B 36.

Weld base plates (2 each), to sides of signpost and stub post flanges.

(W) Welds to be continuous fillet welds and of a depth equal to the thickness of the flange for the post unless otherwise specified.

Construct the footing as shown for normal footing in earth. Where solid rock is encountered, the alternate design for footing in solid rock may be used with the approval of the Engineer.

Dispose of all excavation for the footing in the area adjacent to the footing and shape to normal ground contour, unless directed otherwise by the Engineer.

Hold the stub post in proper position by an approved device to ensure that it remains in proper position upon completion of concrete placement.

The contract price for size of footing required to be full compensation of footing as detailed hereon, including all necessary excavation regardless of character.

1 Not for single post installations.

Possible Contract Item:
Steel Breakaway Sign Post

 Iowa Department of Transportation	REVISION
	3 10-19-10
	SI-113
SHEET 1 of 3	
REVISIONS: Corrected 'D' dimension in Section A-A.	
<i>Deanna Maifeld</i> APPROVED BY DESIGN METHODS ENGINEER	
SUPPORT STRUCTURES - STEEL BREAKAWAY POSTS	

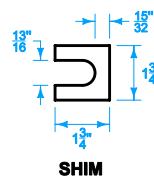

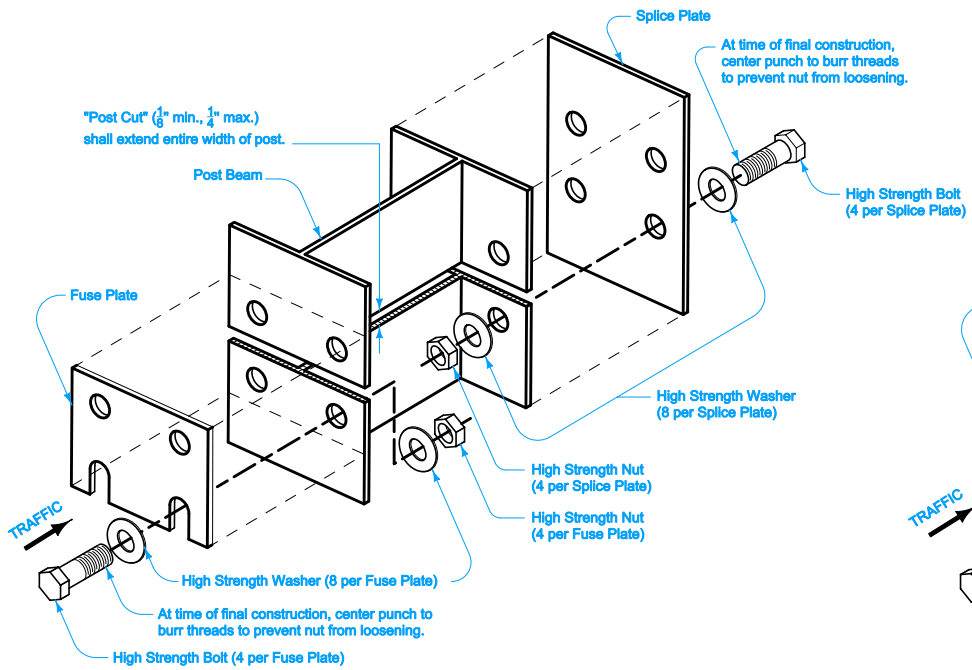

Hinge Alternate 1
(With Splice Plate)

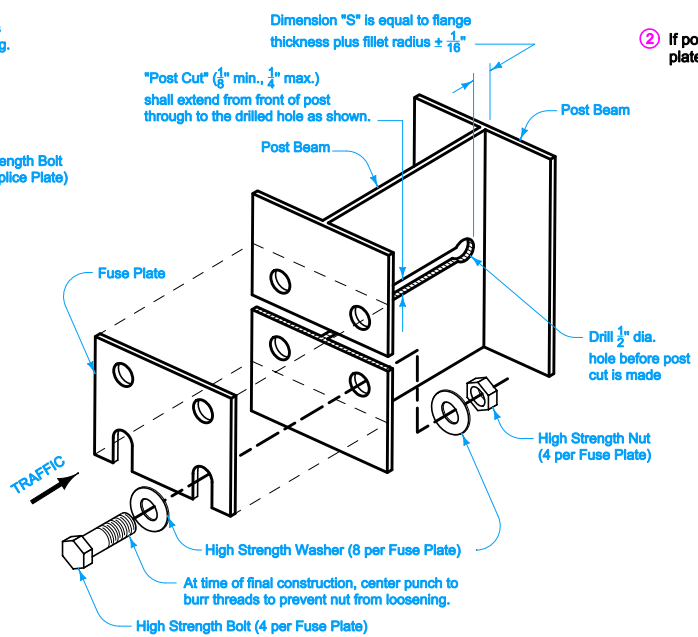

Hinge Alternate 2
(One-Piece Post)

② If post is to be transported after cut is made, bolt a "splice plate" to front of post to prevent damage to the post.

FUSE PLATE ASSEMBLY

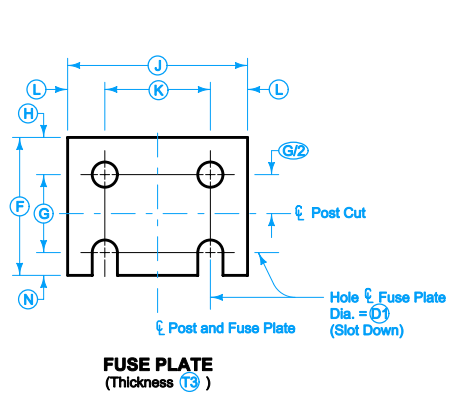

FUSE PLATE
(Thickness T₃)

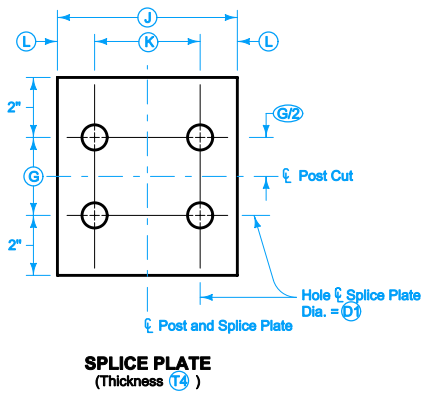

SPLICE PLATE
(Thickness T₄)

Bolt Size	Torque
1/2"	100 Ft. Lbs.
5/8"	180 Ft. Lbs.
3/4"	320 Ft. Lbs.
7/8"	470 Ft. Lbs.

Post Size	Bolt Dia.	FUSE AND SPLICE PLATE DATA									
		F	G	H	J	K	L	N	D1	T3	T4
W6x9	1/2"	3 5/8"	2"	1 5/8"	4"	2 1/4"	7 5/8"	1 1/2"	9 5/8"	1 1/4"	1 1/4"
W6x12	5/8"	3 3/4"	2"	1 5/8"	4"	2 1/4"	7 5/8"	5/8"	11 1/8"	3 3/8"	1 1/4"
W6x15	3/4"	4 1/2"	2 1/2"	1 3/4"	6"	3 1/4"	1 1/4"	3"	13 1/8"	1 1/2"	1 1/4"
W8x18	3/4"	4 1/2"	2 1/2"	1 3/4"	5 1/4"	2 3/4"	1 1/4"	3 3/4"	13 3/8"	1 1/2"	1 1/4"
W8x21	7/8"	4 7/8"	2 1/2"	1 3/4"	5 1/4"	2 3/4"	1 1/4"	7"	15 1/8"	5/8"	3 3/8"
W10x22	7/8"	5 3/8"	3"	1 1/2"	5 3/4"	2 3/4"	1 1/2"	7 1/8"	15 1/8"	5/8"	3 3/8"
W10x26	7/8"	5 3/8"	3"	1 1/2"	5 3/4"	2 3/4"	1 1/2"	7 1/8"	15 1/8"	5/8"	3 3/8"
W12x26	7/8"	5 3/8"	3"	1 1/2"	6 1/2"	3 1/2"	1 1/2"	7 1/8"	15 1/8"	5/8"	3 3/8"

<p>Iowa Department of Transportation</p> <p>STANDARD ROAD PLAN</p> <p>REVISIONS: Corrected 'D' dimension in Section A-A.</p> <p><i>Deanna Maifeld</i> APPROVED BY DESIGN METHODS ENGINEER</p> <p>SUPPORT STRUCTURES - STEEL BREAKAWAY POSTS</p>	<p>REVISION</p> <p>3 10-19-10</p>
	<p>SI-113</p> <p>SHEET 2 of 3</p>

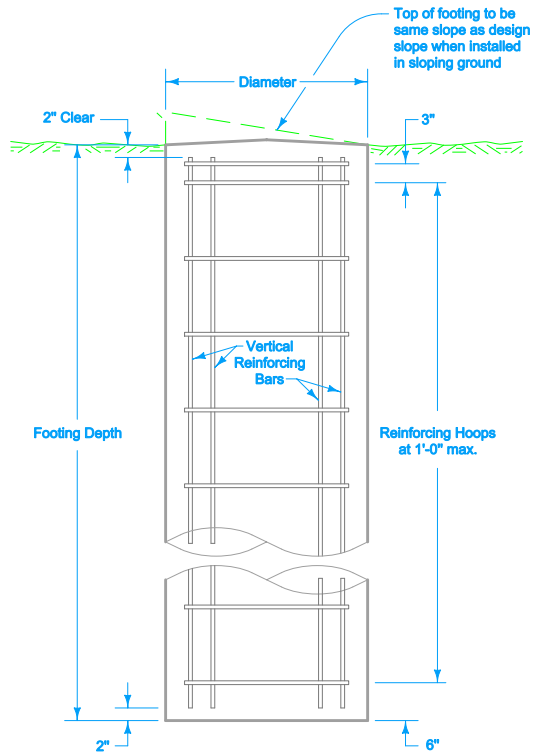

**INSTALLATION
NORMAL FOOTING IN EARTH**

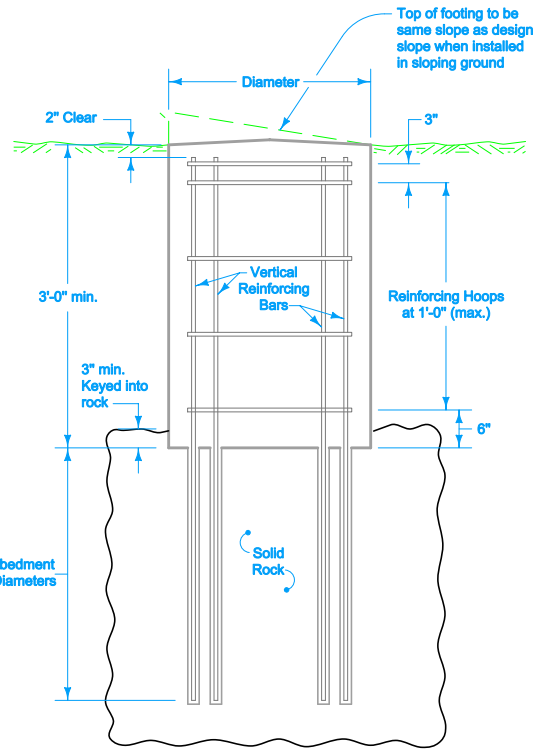

**ALTERNATE DESIGN
FOOTING IN SOLID ROCK** ④

③ Lengths are for normal footings. Required length may vary where alternate rock design is used.

④ Set vertical bars in solid rock as follows:
 1. Drill holes twice bar diameter and fill with water.
 2. When hole is fully saturated; blow water out and fill two-thirds depth with sand cement mortar.
 3. Insert bar and consolidate mortar.
 4. Fill hole to top with mortar.

FOOTING REINFORCING DATA					
Post Size	Stub Length	Footing		Vertical Rein. Bar	
		Diameter	Depth	Size	Length ③
W6x9	2'-6"	2'-0"	6'-0"	No. 6	5'-8"
W6x12	2'-6"	2'-0"	6'-0"	No. 6	5'-8"
W6x15	2'-6"	2'-0"	6'-6"	No. 6	6'-2"
W8x18	2'-6"	2'-0"	7'-0"	No. 6	6'-8"
W8x21	3'-0"	2'-8"	7'-6"	No. 8	7'-2"
W10x22	3'-0"	2'-8"	8'-0"	No. 8	7'-8"
W10x26	3'-0"	2'-8"	8'-6"	No. 8	8'-2"
W12x26	3'-0"	2'-8"	9'-0"	No. 8	8'-8"

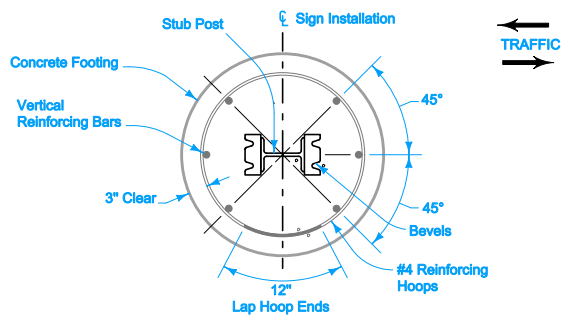

**PLAN
(Reinforcing Placement and Sign Orientation)**

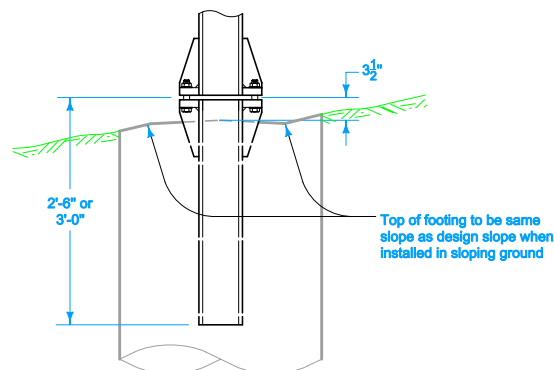

BREAKAWAY POST INSTALLATION

 Iowa Department of Transportation	REVISION
	3 10-19-10
STANDARD ROAD PLAN	SI-113
REVISIONS: Corrected 'D' dimension in Section A-A.	
<i>Deanna Maifeld</i> APPROVED BY DESIGN METHODS ENGINEER	
SUPPORT STRUCTURES - STEEL BREAKAWAY POSTS	