

SECTION A-A
DOWELED PCC PAVEMENT

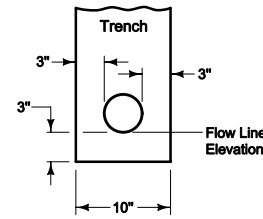

DRAIN PLACEMENT ④

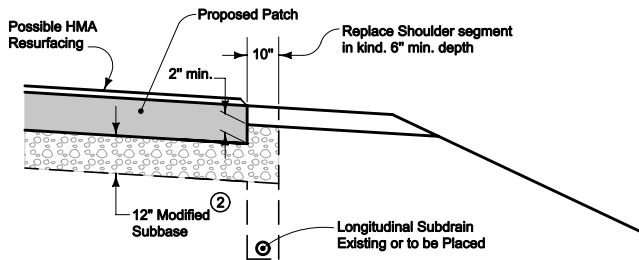

MODIFIED SUBBASE AND SUBDRAIN
IF LONGITUDINAL SUBDRAIN IS PRESENT OR IS TO BE PLACED

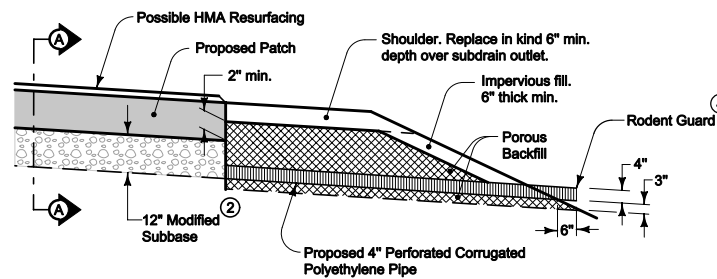

MODIFIED SUBBASE AND SUBDRAIN ④
WITHOUT LONGITUDINAL SUBDRAIN

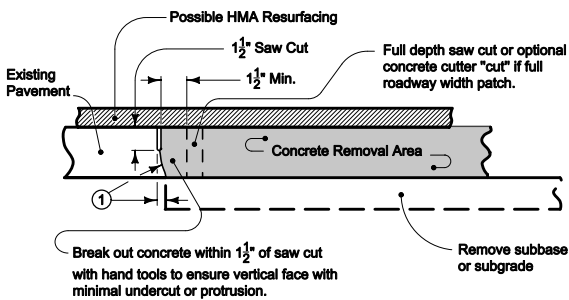

PAVEMENT REMOVAL DETAILS

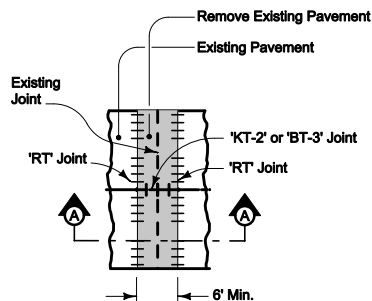

FULL ROADWAY WIDTH PATCH

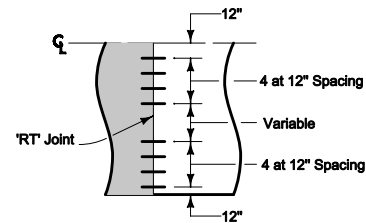

TYPICAL HALF PLAN

Place Full Depth Patch with 'EF' Joint after the final lift of asphalt has been placed. Porous Backfill and Subdrain may be placed prior to construction of resurfacing of shoulders.

Place and pay for Full Depth Patch according to Full Depth Patch specifications and Standard Road Plan RR-4, except as noted on this sheet.

Place Full Depth Patch and 'EF' Joint full width of the roadway. If roadway has PCC shoulders, extend 'CF' joint across shoulder. Cost of placing 'CF' joint is incidental to 'EF' joint.

See PV-1 for joint and bar placement details.

- ① The face of the patch should be near vertical. No need to remove protrusions smaller than 2 inches if uniformly tapered from bottom of saw cut to bottom of patch. A step or ledge on this face is not allowed.
- ② 12 inches Modified Subbase is required under Full Depth Patch with 'EF' Joint. Modified Subbase should extend over longitudinal subdrain, if present.
- ③ Unless otherwise noted in the plans, depth of patch, T, is 12 inches regardless of existing pavement thickness.
- ④ If longitudinal subdrain (shoulder) is not to be placed or if it is not present on side of roadway to be patched, then place 4 inch Perforated Corrugated PE Pipe at low end(s) of patch. Use removable grate rodent guard except for projects using recycled PCC subbase where a removable fork rodent guard is required. Refer to RF-19E for rodent guard details. Refer to Drain Placement detail.

Possible Contract Items:

- Joint Assembly, EF
- Patches, Full-Depth Repair
- Patches by Count (Repair)
- Patches, Full-Depth Finish, by Area
- Patches, Full-Depth Finish, by Count
- Subdrain, Longitudinal, (Patches) 4"
- Subbase Patch with EF Joint

Possible Tabulation:
102-6C

 Iowa Department of Transportation	REVISION	
	3	10-19-10
	STANDARD ROAD PLAN RR-1 SHEET 1 of 1	
REVISIONS: Changed subdrain size to 4". Changed 6" Special Backfill to 12" Modified Subbase. Added minimum drain trench width. Added Rodent Guard.		
<i>Deanna McFalls</i> APPROVED BY DESIGN METHODS ENGINEER		
FULL DEPTH PATCH WITH 'EF' JOINT IN PCC		