

PLAN VIEW OF BRIDGE BERM AREA

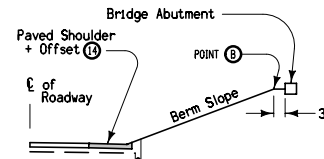

SECTION A-A

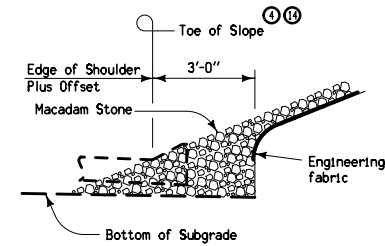

PARTIAL SECTION A-A  
As constructed by others

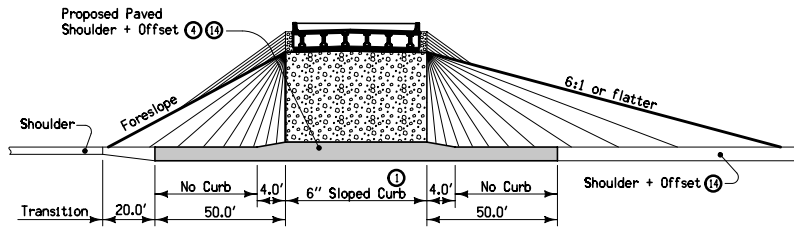

SIDE VIEW BENEATH BRIDGE

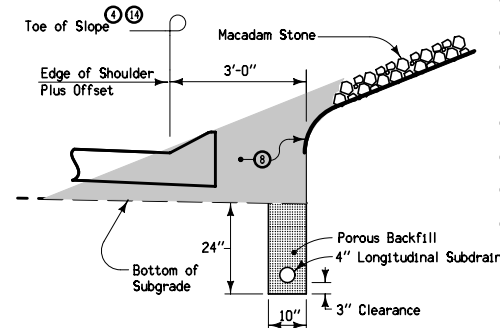

PARTIAL SECTION A-A  
Proposed construction

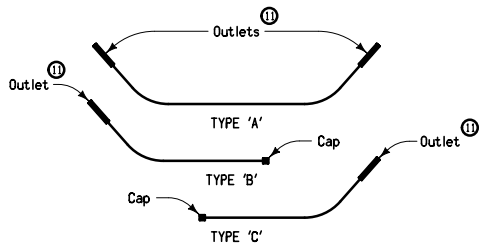

SUBDRAIN LAYOUT TYPES

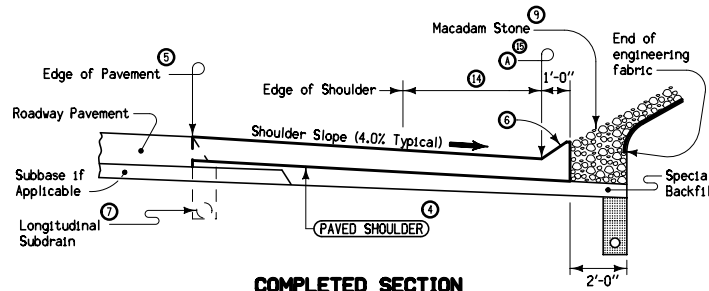

COMPLETED SECTION

The cost of removal, stockpiling and placement of the macadam stone shall be considered incidental to "Paved Shoulder, P.C. Concrete".

For additional information see Bridge Situation Plan

- ① Width of bridge slab + 3' on each side. Build 6" sloped curb to this width.
- ② Foreslope transition for bridge. Refer to Typical 4303.
- ③ Continue shoulder slope through crosshatched area.
- ④ See typical cross-sections for details of paved shoulder.
- ⑤ If roadway pavement is newly-constructed PCC, use BT-1 or BT-2 joint. If roadway pavement is existing PCC, use BT-3, BT-4, or BT-5 joint. See PV-1.
- ⑥ 6" sloped curb. Refer to PV-2.
- ⑦ Roadway subdrain location. Use caution when excavating. Maintain porous material in trench to bottom of roadway pavement.
- ⑧ Remove and stockpile macadam stone. Carefully separate the macadam stone from the surrounding soil. Preserve the integrity of the engineering fabric.
- ⑨ Place clean macadam stone from stockpile.
- ⑩ Approximate location of bridge berm subdrain.
- ⑪ RF-19E subdrain outlet. When flow of subdrain does not require an outlet at both ends, cap the end without an outlet in a method approved by the Engineer.
- ⑫ 2 x (shoulder width).
- ⑬ "X" distance based on station difference between points C2 and C3.
- ⑭ 5' offset unless otherwise noted on the Bridge Situation Plan. 4' offset minimum.
- ⑮ Point 'A' is the toe of the berm as shown in the Berm Slope Location Table.

Possible Contract Items:

Longitudinal Subdrain (Shoulder), 4-inch  
Subdrain Outlet, RF-19E  
Paved Shoulder, P.C. Concrete  
Special Backfill

Possible Tabulation: 104-9

 <b>Iowa Department of Transportation</b> <b>STANDARD ROAD PLAN</b>	REVISION 3 04-20-10
	<b>RL-15</b>
	SHEET 1 of 1
<small>REVISIONS: Updated references to renamed standards.</small> <i>Deanna McFalls</i> <small>APPROVED BY DESIGN METHODS ENGINEER</small>	
<b>BRIDGE BERM GRADING WITH RECOVERABLE SLOPE</b>	