

BAR PLACEMENT
(Applies to all joints unless otherwise detailed)

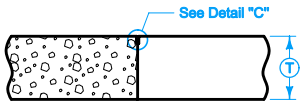

'B'
PLAIN JOINT
Abutting Pavement Slabs

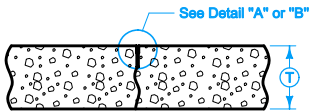

'C'
CONTRACTION JOINT

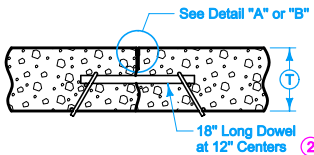

'CD'
DOWELED CONTRACTION JOINT

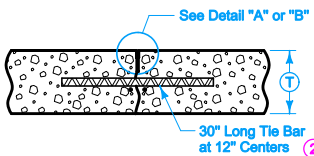

'CT'
TIED CONTRACTION JOINT

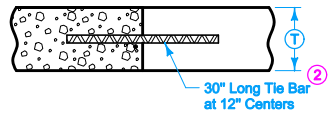

'DW'
DAY'S WORK JOINT (Non-Working)

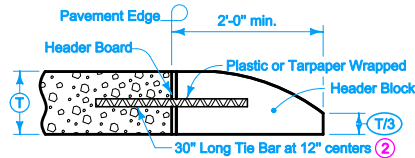

'HT'
HEADER JOINT
(End Rigid Pavement)

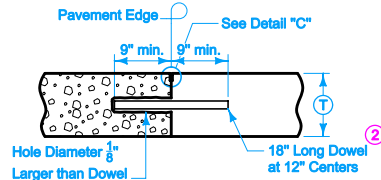

'RD'
ABUTTING PAVEMENT JOINT

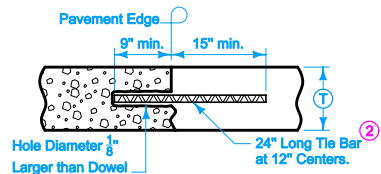

'RT'
ABUTTING PAVEMENT JOINT RIGID TIE

TRANSVERSE CONTRACTION

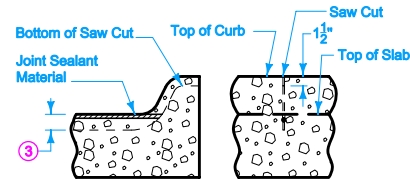

'C' JOINT IN CURB
(Match 'CT', 'CD', or 'C' Joint in Pavement.)

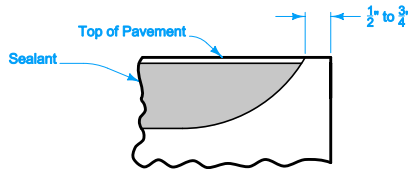

SECTION A-A
(Detail at Edge of Pavement)

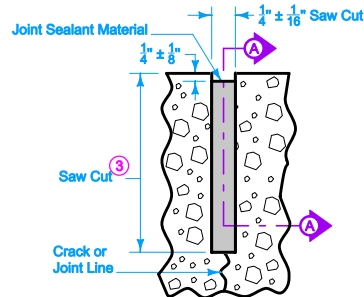

DETAIL "A"
(Saw cut formed by conventional concrete sawing equipment)

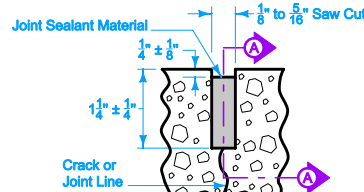

DETAIL "B"
(Saw cut formed by approved early concrete sawing equipment)

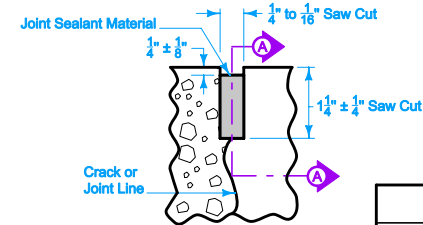

DETAIL "C"

- ① See dowel assemblies for fabrication details.
- ② See Bar Size Table.
- ③ Depth of saw cut shall be $T/3 \pm \frac{1}{4}$, except 'C' joint shall be $T/4 \pm \frac{1}{4}$.
- ④ Locate 'DW' joint at a midpanel location between future 'C' or 'CD' joints. Make it no closer than 5 feet to a 'C' or 'CD' joint.
- ⑤ Place bars within the limits shown under dowel assemblies.
- ⑥ Edge with $\frac{1}{4}$ inch tool for length of joint indicated if formed; edging not required when cut with diamond blade saw. Remove header block and board when second slab is poured.
- ⑦ When tying into old pavement, T represents the depth of sound Portland Cement Concrete.
- ⑧ Unless otherwise specified, transverse contract joints in mainline pavement shall be 'CD' when T is greater or equal to 8 inches. 'C' when T is less than 8 inches.
- ⑨ 'RT' joint may be used in lieu of 'DW' joint at the end of the days work. Any pavement damaged due to the drilling shall be removed at the Contractor's expense.

BAR SIZE TABLE		
T	Dowel Diameter	Tie Bar Size
< 8"	$\frac{3}{4}$ "	#6
$\geq 8"$ but < 10"	$\frac{1}{4}$ "	#10
$\geq 10"$	$\frac{1}{2}$ "	#11

 Iowa Department of Transportation	REVISION
	1 10-19-10
	PV-1 SHEET 1 of 5
REVISIONS: Sheet 3 changed 'ED', 'EE', 'EF' joint note. Sheet 4 changed 'EF' joint opening width in table from 4" to 3.5".	
<i>Deanna Maifield</i> APPROVED BY DESIGN METHODS ENGINEER	
JOINTS	

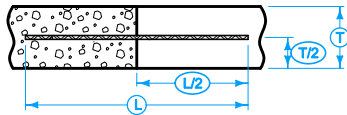

TIE BAR PLACEMENT
(Applies to all joints unless otherwise detailed) (7)

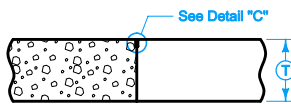

'B' PLAIN JOINT
Abutting Pavement Slabs

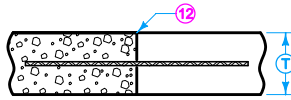

'BT' ABUTTING PAVEMENT JOINT - RIGID TIE

T	Joint	Bars	Bar Length and Spacing
< 8"	'BT-1'	#4	36" Long at 30" Centers
≥ 8"	'BT-2'	#5	36" Long at 30" Centers

3/4" Dia. Hole for BT-3 and BT-4 Joint
5/8" Dia. Hole for BT-5 Joint

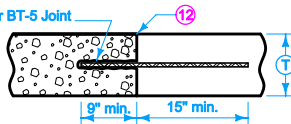

'BT' ABUTTING PAVEMENT JOINT - RIGID TIE (DRILLED)

T	Joint	Bars	Bar Length and Spacing
< 8"	'BT-5'	#4	24" Long at 30" Centers
≥ 8"	'BT-3'	#5	24" Long at 30" Centers
	'BT-4'		24" Long at 15" Centers

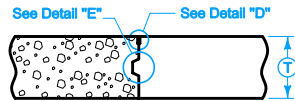

'K' KEYED JOINT FOR ADJACENT SLABS
(Where T is 8" or more)

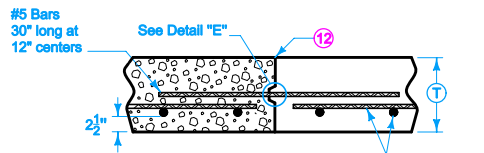

'KS-1' Single-Reinforced Pavement (Bridge Approach)

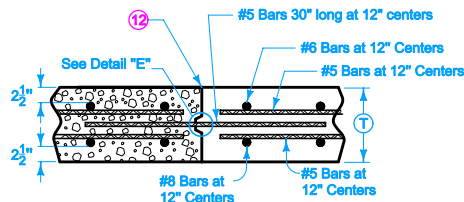

'KS-2' Double-Reinforced Pavement (Bridge Approach)

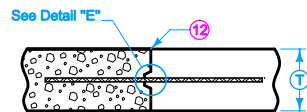

'KT' ABUTTING PAVEMENT JOINT - KEYWAY TIE (10) (13)

T	Joint	Bars	Bar Length and Spacing
< 8"	'KT-1'	#4	30" Long at 30" Centers
≥ 8"	'KT-2'	#5	30" Long at 30" Centers
	'KT-3'		30" Long at 15" Centers

LONGITUDINAL CONTRACTION

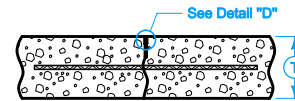

'L' CONTRACTION JOINT (13)

T	Joint	Bars	Bar Length and Spacing
< 8"	'L-1'	#4	36" Long at 30" Centers
≥ 8"	'L-2'	#5	36" Long at 30" Centers
	'L-3'		36" Long at 15" Centers

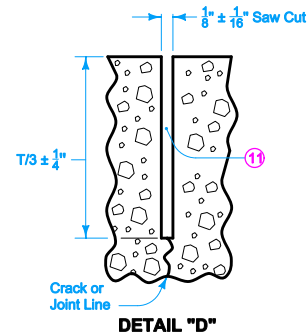

DETAIL "D"

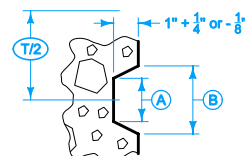

DETAIL "E"

KEYWAY DIMENSIONS			
Keyway Type	Pavement Thickness T	A	B
Standard	8" or greater	1 3/4"	2 3/4"
Narrow	Less than 8"	1"	2"

- (7) When tying into old pavement, (T) represents the depth of sound Portland Cement Concrete.
- (10) Bar supports may be necessary for fixed form paving to insure the bar remains in a horizontal position in the plastic concrete.
- (11) Sealant or cleaning not required.
- (12) Sawing or sealing of joint not required.
- (13) The following joints are interchangeable, subject to the pouring sequence:
'BT-1', 'L-1', and 'KT-1'
'KT-2' and 'L-2'
'KT-3' and 'L-3'

<p>Iowa Department of Transportation</p> <p>STANDARD ROAD PLAN</p> <p>REVISIONS: Sheet 3 changed 'ED', 'EE', 'EF' Joint note. Sheet 4 changed 'EP' joint opening width in table from 4" to 3.5".</p> <p style="text-align: right;"><i>Deanna Maifeld</i> APPROVED BY DESIGN METHODS ENGINEER</p>	REVISION
	1 10-19-10
	PV-1 SHEET 2 of 5
JOINTS	

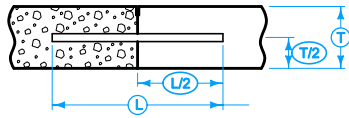

DOWEL PLACEMENT
(Applies to all joints unless otherwise detailed)

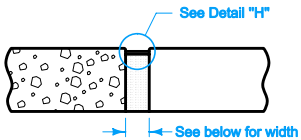

'CF' JOINT

TYPE	WIDTH
CF-1	2"
CF-2	2½"
CF-3	3"
CF-4	3½"

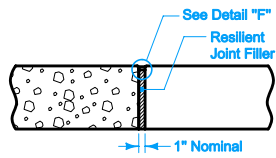

'E' JOINT
1" EXPANSION JOINT

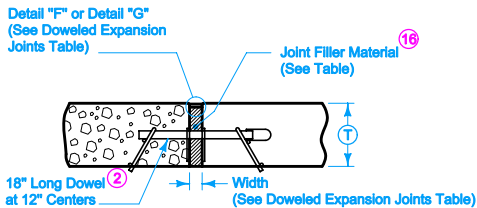

'ED', 'EE', 'EF' DOWELED EXPANSION JOINT

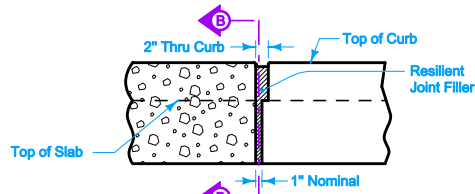

'E' JOINT IN CURB
(View at Back of Curb)

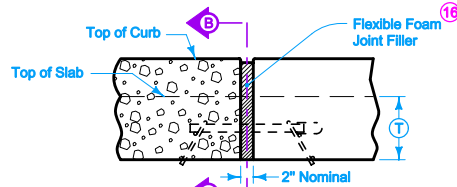

'EE' JOINT IN CURB
(View at Back of Curb)

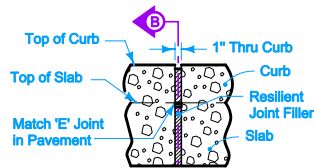

'ES' JOINT IN CURB
(View at Back of Curb)

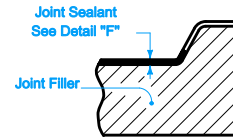

SECTION B-B

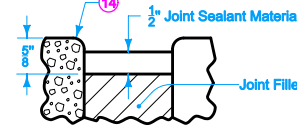

DETAIL "F"

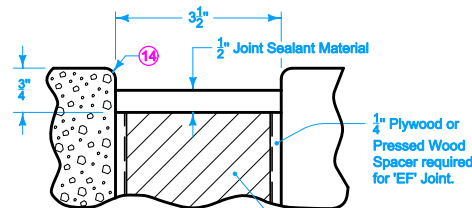

DETAIL "G"

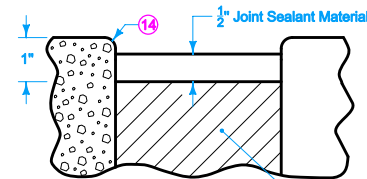

DETAIL "H"

- ② See Bar Size Table.
- ⑭ Edge with ¼ inch tool for length of joint indicated if formed; edging not required when cut with diamond blade saw.
- ⑮ See dowel assemblies for fabrication details and placement limits. The free end of dowel bar shall be coated to prevent bond with pavement. At intake locations, dowel bars may be cast-in-place.
- ⑯ Holes for Joint Material shall be predrilled or preformed for appropriate dowel size.
- ⑰ Compact tire buffings by spading with a square-nose shovel.

DOWELED EXPANSION JOINTS		
TYPE	WIDTH	FILLER MATERIAL ⑯
ED	1"	Resilient (Detail "F")
EE	2"	Flexible Foam (Detail "F")
EF	3½"	Flexible Foam (Detail "G")

BAR SIZE TABLE			
Ⓣ	< 8"	≥ 8" but < 10"	≥ 10"
Dowel Diameter	¾"	1¼"	1½"

 Iowa Department of Transportation	REVISION
	1 10-19-10
	STANDARD ROAD PLAN PV-1 SHEET 3 of 5
REVISIONS: Sheet 3 changed 'ED', 'EE', 'EF' Joint note. Sheet 4 changed 'EF' joint opening width in table from 4" to 3.5".	
<i>Deanna Maifield</i> APPROVED BY DESIGN METHODS ENGINEER	
JOINTS	

EXPANSION

CONTRACTION JOINTS

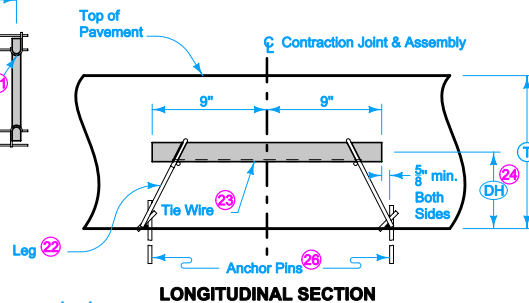
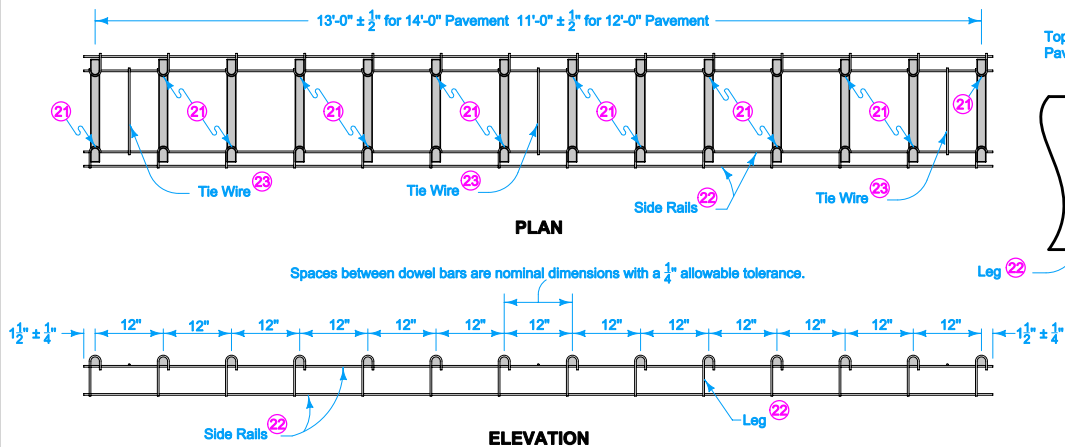

- 18 Dowel bars shall be 18 inches long with a tolerance of $\pm \frac{1}{8}$ inch. The centerline of individual dowels shall be parallel to the other dowels in the assembly within $\pm \frac{1}{8}$ inch.
- 19 Wire sizes shown are the minimum required. Wires shall have a minimum tensile strength of 50 ksi.
- 20 Details apply to both transverse contraction and expansion joints.
- 21 Weld alternately throughout.
- 22 #1/0 gauge (0.306 inch diameter) wire.
- 23 #10 gauge (0.135 inch diameter) wire, welded or friction fit to upper side rail, both sides.
- 24 Measured from the centerline of dowel bar to bottom of lower side rail + $\frac{1}{4}$ inch.
- 25 Clip and remove center portion of tie during field assembly.
- 26 Per lane width, a minimum of (8) anchor pins evenly spaced (4 per side), to prevent movement of assembly during construction. Assemblies placed on pavement or PCC base shall be anchored with devices approved by the Engineer.
- 27 0.250 inch diameter wire.

EXPANSION JOINTS

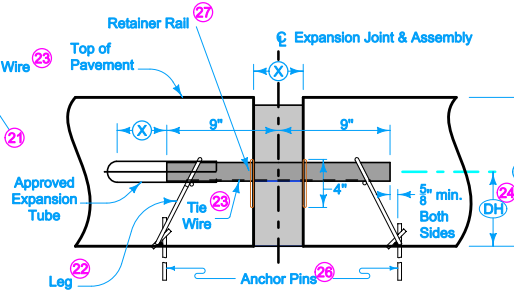
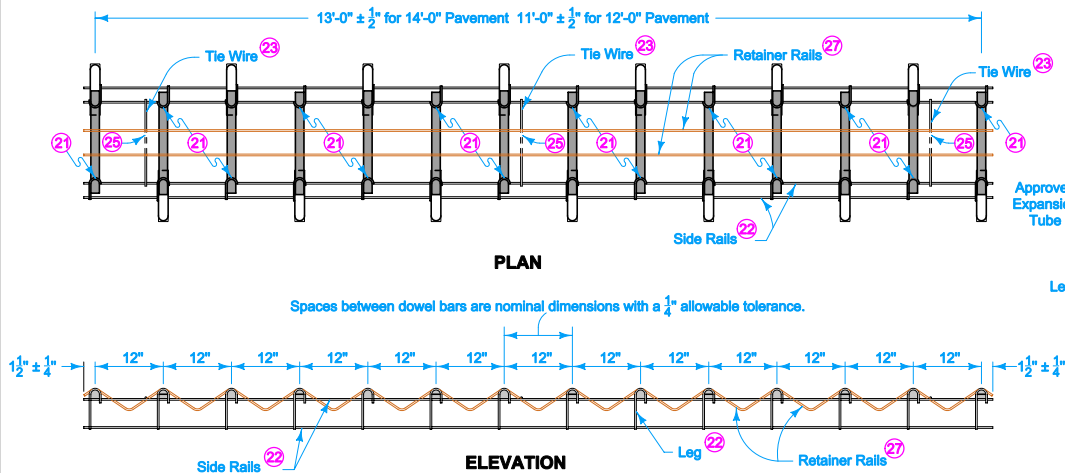

DOWEL HEIGHT AND DIAMETER		
T	DH 24	Diameter
7" to 7 1/2"	3 3/4"	3/4"
8" to 9 1/2"	4 3/4"	1 1/4"
10" to 11 1/2"	5 1/2"	1 1/2"
12" to 13"	6 1/2"	1 5/8"

JOINT OPENING AND EXPANSION TUBE EXTENSION		
Joint Type	X	Minimum Tube Length
"ED"	1"	6"
"EE"	2"	7"
"EF"	3 1/2"	9"

Iowa Department of Transportation

STANDARD ROAD PLAN

REVISIONS: Sheet 3 changed 'ED', 'EE', 'EF' Joint note. Sheet 4 changed 'EP' joint opening width in table from 4" to 3.5".

Deanna Maifeld
APPROVED BY DESIGN METHODS ENGINEER

REVISION	1	10-19-10
PV-1		SHEET 4 of 5

DOWEL ASSEMBLIES 18 19 20

JOINTS

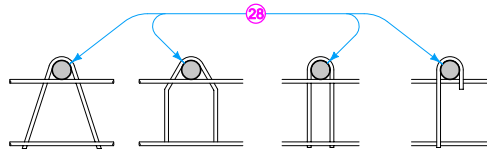

OPTIONAL LEG SHAPES

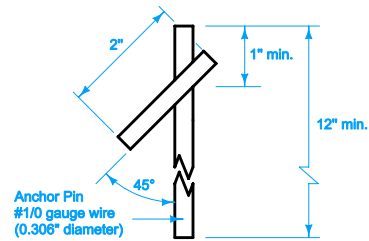

ANCHOR PIN

- 18 Dowel bars shall be 18 inches long with a tolerance of $\pm \frac{1}{8}$ inch. The centerline of individual dowels shall be parallel to the other dowels in the assembly within $\pm \frac{1}{8}$ inch.
- 19 Wire sizes shown are the minimum required. Wires shall have a minimum tensile strength of 50 ksi.
- 20 Details apply to both transverse contraction and expansion joints.
- 28 Diameter of bend around dowel is dowel diameter + $\frac{1}{8}$ to $\frac{3}{16}$ inches.

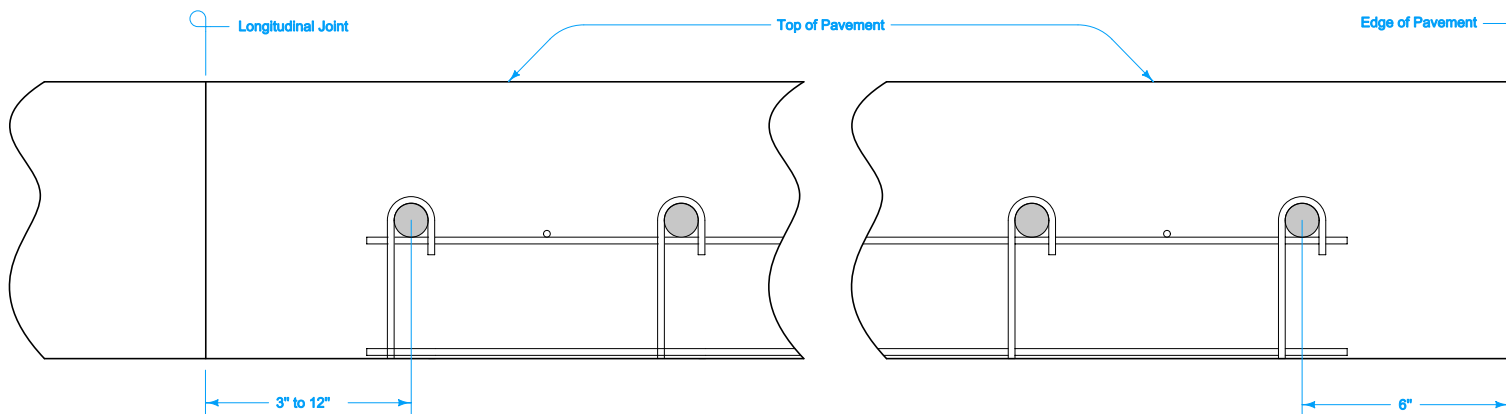

PLACEMENT LIMITS

DOWEL ASSEMBLIES 18 19 20

 Iowa Department of Transportation	REVISION	
	1	10-19-10
STANDARD ROAD PLAN		PV-1
		SHEET 5 of 5
<small>REVISIONS: Sheet 3 changed 'ED', 'EE', 'EF' Joint note. Sheet 4 changed 'EF' joint opening width in table from 4" to 3.5".</small>		
<i>Deanna Maifeld</i> <small>APPROVED BY DESIGN METHODS ENGINEER</small>		
JOINTS		