

Possible Sidewalk - exact shape and dimensions determined by the Engineer to comply with individual project requirements.

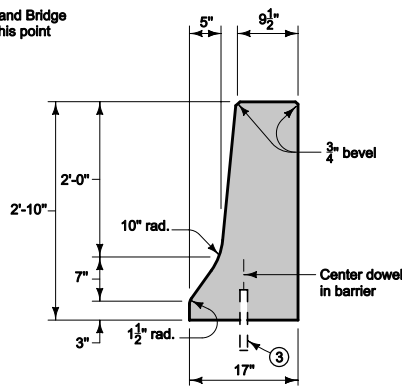

FULL BARRIER RAIL SECTION

Install a 'C' joint in concrete approach barrier to match the location of each joint in both roadway and bridge approach pavement.

- ① Typical joint spacing and location. Specific project requirements shall be as directed by the Engineer.
- ② Match boxout width to existing curb and gutter joint. Use 2 foot wide boxout where curb and gutter are not constructed.
- ③ #8 x 8 inch deformed bars or 1 inch diameter smooth.
- ④ For joint detail, see PV-1.
- ⑤ Bottom width of barrier is maintained at 17 inches.
- ⑥ Bottom width of barrier transitions from 8 to 17 inches.
- ⑦ Required sidewalk will be measured and paid for separately.
- ⑧ Additional concrete quantity required for extended roadway pavement will be included in roadway paving quantity.
- ⑨ Place no delineator or object marker in front of, or on, the barrier.
- ⑩ Approximately 2.0 cubic yards of concrete are required to construct barrier as shown. Amount may vary depending on individual site requirements.

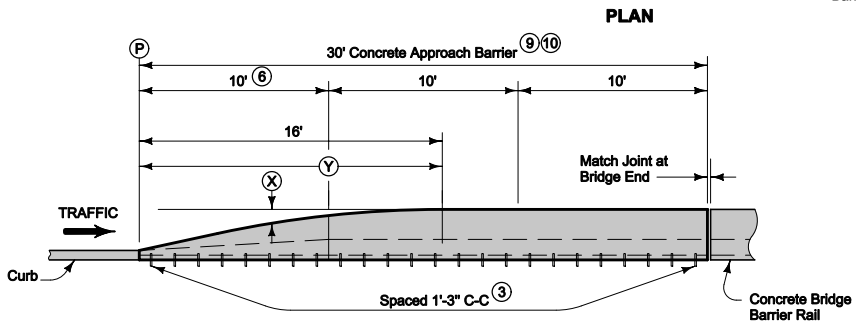

ELEVATION

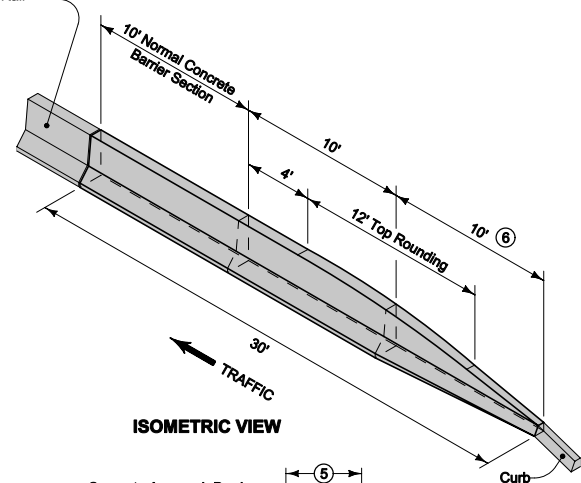

ISOMETRIC VIEW

OFFSETS FOR ROUNDED BARRIER TOP																
Y = Distance from (P)	ft. 1.0	2.0	3.0	4.0	5.0	6.0	7.0	8.0	9.0	10.0	11.0	12.0	13.0	14.0	15.0	16.0
X = Offset to Rounded Top	ft. 2.13	1.91	1.70	1.48	1.26	1.06	0.87	0.70	0.54	0.42	0.30	0.20	0.12	0.06	0.02	0.00

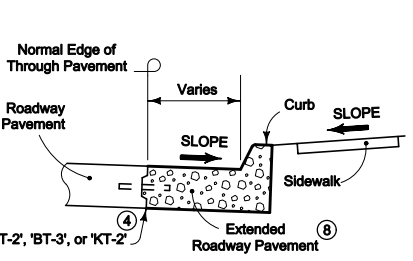

SECTION A-A

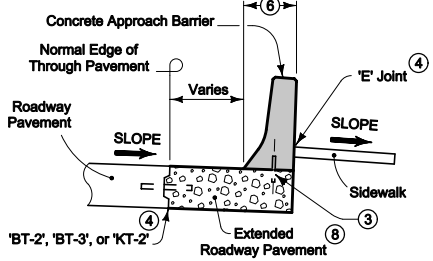

SECTION B-B

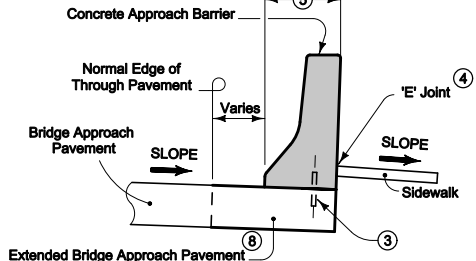

SECTION C-C

Possible Contract Item:
Concrete Barrier, Tapered End, BA-108

Possible Tabulation:
108-18B

 Iowa Department of Transportation	REVISION
	New 04-20-10
STANDARD ROAD PLAN	BA-108
REVISIONS: New. Replaces RE-46.	SHEET 1 of 1
<i>Deanna Maiford</i> APPROVED BY DESIGN METHODS ENGINEER	
CONCRETE BARRIER TAPERED END SECTION (35 MPH OR LESS)	