



---

## STEEL H PILES

### **GENERAL**

Steel H-Piles shall be rolled from high-strength low-alloy Columbium-vanadium structural steel, meeting the requirements of Article 4167 of the Standard Specifications and the requirements of ASTM A 572 / A 572 M Grade 50 (345) and shall have cross section dimensions meeting the current edition of ASTM A 6 / A 6 M for the section number designated.

Steel H-Piles shall not be accepted in the field without the Mill Test Report, proper identification list. (project number, heat number, County, number of pieces, design number, and contractor's name)

Steel H-Piles shall be free of injurious defects, shall have a smooth finish, shall be uniform in thickness and shall be true to dimensions, weights, and required thickness.

Steel H-Piles shall be properly identified with heat number, size, length, and mill identification / name marked on each pile.

Steel H-Piles shall be melted and manufactured in the United States.

Steel H-Piles shall have a minimum yield point of 50 KSi (345 MPa) and a minimum tensile strength of 65 KSi (450 MPa). Elongation shall meet the requirements of ASTM A 572 / A 572 M for size specified.

Note: For grade 50 (345) steel of thicknesses  $\frac{3}{4}$ " (20 mm) and less, the tensile strength shall be a minimum of 70 KSi (485 MPa).

For welding and pre-heat requirements, please refer to [IM 558](#)

Shipping invoice shall have the following information:

1. Company's name and address (imprint)
2. Customer / contractor's name
3. Quantity of piles (number)
4. Material description (type & length)
5. Project number
6. Heat number
7. Shipping date

### **SPLICING/WELDING STEEL PILE**

Field welding of steel pile shall conform to the requirements of [IM 558](#) and preapproved welding procedures requiring the use of backing plates. Only field welds are permitted and only at air temperature above  $0^{\circ}\text{F}$  ( $-18^{\circ}\text{C}$ ). Pre-heating shall be required. Welding shall be performed by a state certified field welder.

---

The number of permitted splices to achieve plan-specified lengths of steel H-piles shall be limited to the following:

<u>Plan Pile Length in Feet (Meters)</u>	<u>Number of Permitted Welds (Splices)</u>
0-50 (0-15)	0
51-100 (15.1-30)	1
101-150 (30.1-45)	2

**NOTE:** When steel H-piles are to be spliced, the shortest pile length shall be the last added length.

### **MONITORING INSPECTION**

1. Minimum sample rate frequency - one sample per source per size per District
2. The District Materials Engineer will coordinate sampling.
3. Samples shall be properly identified by heat number, source and size, and shall be accompanied with their respective Mill Test Report.
4. Sample size shall be a full cross-sectional area of a minimum 1.5 ft. (460 mm) in length.
5. Field Material personnel shall secure the sample from the project site with all required information (mill test report, monitor inspection form documentation).
6. The contractor shall be responsible for cutting the required sample.
7. Samples will be processed in the Central Laboratory and shall be measured for width and depth, dimensional compliance and weighed for compliance with ASTM A6/A6M Specifications of  $\pm 2.5\%$  of the theoretical or specified amounts.

### **Cut-off Pile Pieces**

Pile cut-ff pieces shall be accepted on the basis of Mill Test Report and proper identification (heat number and source). Welding of pile cut-off pieces shall conform to the requirements of IM 558. It is the contractor's responsibility to have the cut-off pilings properly identified, marked and to possess all required paperwork (Mill Test Analysis and Laboratory Test Report). Un-identified cut-off pile pieces shall not be accepted (heat number, source, and mill test report).

---

**ACCEPTANCE**

Steel piling shall be accepted on the basis of the Mill Test Report and shall be from an approved source. The Mill Test Report shall show compliance with the tolerances outlined in ASTM A6/A6M. Any test sample that fails to comply with the requirements and tolerances will be handled on an individual basis as directed by the Materials Engineer and/or a designated representative.

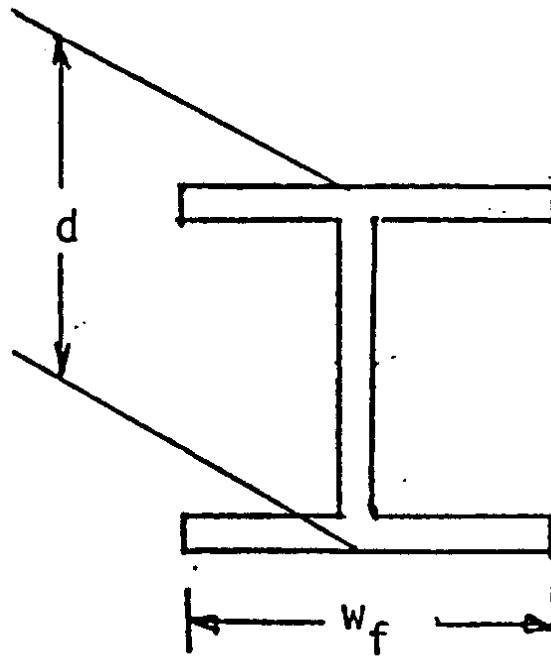

**Certification Statement (Sample)**

We hereby certify that the contents of this report are accurate. All test results and fabrication performed by this material manufacturer are in compliance with the requirements of ASTM A 572 and the cross sectional dimensions of ASTM A 6 / A6M. We also certify that this material is melted and manufactured in the USA.

Signed \_\_\_\_\_  
Authorized Representative

Notarized by Notary Public

**(FOR CENTRAL LABORATORY'S USE)  
 DIMENSIONS & TOLERANCES FOR WEIGHT COMPLIANCE**

**H-PILES - ENGLISH**

Designation	Depth, d			Flange Width, w <sub>f</sub>			Min. Acceptable Weight Lbs./Ft. 0.975 Theoretical
	Min.	Theo.	Max.	Min.	Theo.	Max.	
	In.	In.	In.	In.	In.	In.	
HP 14 x 117 x 102 x 89 x 73	14 1/8	14 1/4	14 3/8	14 11/16	14 7/8	15 1/8	114.08
	13 7/8	14	14 1/8	14 9/16	14 3/4	15	99.45
	13 3/4	13 7/8	14	14 9/16	14 3/4	15	86.78
	13 1/2	13 5/8	13 3/4	14 7/16	14 5/8	14 7/8	71.18
HP 12 x 84 x 74 x 63 x 53							81.90
	12	12 1/8	12 1/4	12 1/16	12 1/4	12 1/2	72.15
							61.42
	11 5/8	11 3/4	11 7/8	11 13/16	12	12 1/4	51.68
HP 10 x 57 x 42	9 7/8	10	10 1/8	10 1/16	10 1/4	10 1/2	55.58
	9 5/8	9 3/4	9 7/8	9 15/16	10 1/8	10 3/8	40.95
HP 8 x 36	7 7/8	8	8 1/8	7 15/16	6 1/8	8 3/8	35.10

**(FOR CENTRAL LABORATORY'S USE)  
 DIMENSIONS & TOLERANCES FOR WEIGHT (MASS) COMPLIANCE**

**H-PILES - METRIC**

Designation Nominal mm x kg/m	Depth, d			Flange Width, w <sub>f</sub>			Min. Acceptable Mass kg/m 0.975 Theoretical
	Min.	Theo.	Max.	Min.	Theo.	Max.	
	mm	mm	mm	mm	mm	mm	
HP 360 x 174	358	361	365	373	378	384	169.6
x 152	353	356	360	371	376	382	148.2
x 132	348	351	355	368	373	379	128.7
x 108	343	346	350	365	370	376	105.3
HP 310 x 125	309	312	316	307	312	318	121.9
x 110	305	308	312	305	310	316	107.2
x 93	300	303	307	303	308	314	90.7
x 79	296	299	303	301	306	312	77.0
HP 250 x 85	251	254	258	255	260	266	82.9
x 62	243	246	250	251	256	262	60.4
HP 200 x 53	201	204	208	202	207	213	51.7