

METAL END SECTIONS FOR CIRCULAR PIPES

Pipe Dia. (In.)	Min. Thick. In.	Gage	Dimensions (Inches)				
			A	H	W	L	
15	.064	16	8	6	21	37	30
18	.064	16	8	6	24	40	48
21	.064	16	8	6	27	43	66
24	.064	16	8	6	30	46	84
30	.109	12	12	9	36	60	120
36	.109	12	12	9	42	66	156
42	.109	12	16	12	48	80	192
48	.109	12	16	12	54	86	228
54	.109	12	16	12	60	92	264
60	.109	12	16	12	66	98	300

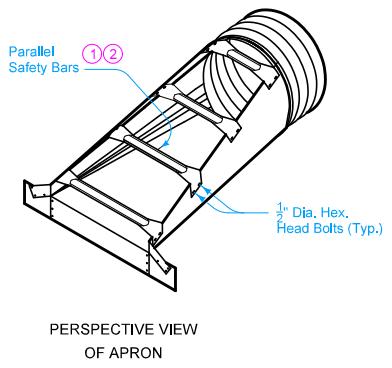
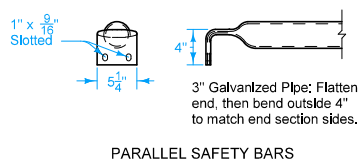
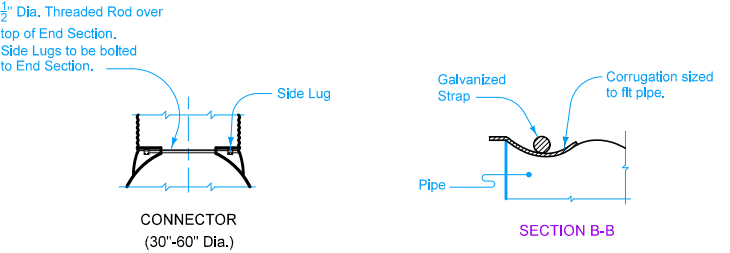

Install aprons and hardware fabricated from galvanized steel complying with Section 4141 of the Standard Specifications. Alternate design details may be submitted to the Engineer for approval.

- Apron may be attached to culvert pipe as follows:
- A. If normal culvert is of circumferential corrugation type, use an approved bolt or clamp to fasten apron directly to apron.
 - B. If normal culvert is of helical corrugation type:
 1. Use an approved sizing ring securely fastened to inside diameter of apron to connect to the culvert pipe using special dimple band connector.
 2. "Dimple" bands will not be allowed when a positive joint is specified.

Refer to Materials I.M. 441 for approved coupling devices.

Repair, to the Engineer's satisfaction, breaks or damage to the coating that occur during handling or installation.

Price bid for "Aprons, Safety Slope" is full compensation for fabrication and installation of the apron.

- ① Number of bars required will vary depending on the length of the end section.
- ② Parallel safety bars are required for pipes 30" diameter and larger. For pipe 24" diameter and smaller, parallel safety bars will be required only when specified in the project plans.

Possible Contract Item:
Aprons, Safety Slope

Possible Tabulation:
104-3

IOWA DOT	REVISION
	1 4-21-20
	STANDARD ROAD PLAN
DR-211	SHEET 1 of 1
REVISIONS: Added Designer Info button.	
APPROVED BY DESIGN METHODS ENGINEER	
METAL SAFETY SLOPE APRON	
6:1 SLOPE	