

FENCE PLAN

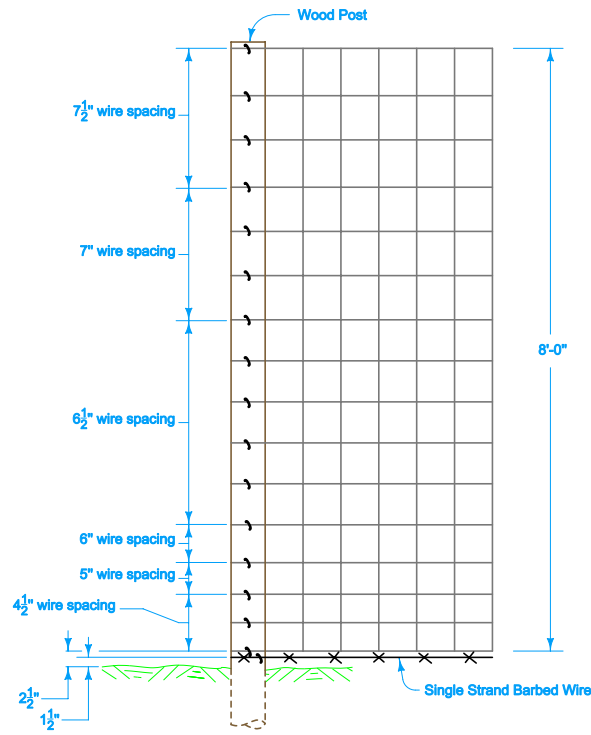

ELEVATION

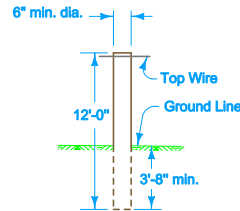

WOOD POST

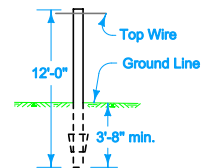

STEEL POST

Space line brace posts according to [MI-103](#) where fencing is continuous and where end, corner, and line brace posts are not specified.

Double wrap barbed wire and tie off at end posts, corner posts, and line brace posts. Single wrap woven wire and tie off. Restart fence to be continued, in like manner.

Fence wire may be placed on either the road side or the field side of posts, depending on local conditions; I.E., on curves, the wire should be placed on the side which would result in the least amount of tension on the staples. This will also apply where wind, drift, or other conditions would exert unusual pressure against the wire.

Furnish woven Wire Fence Fabric that meets or exceeds the requirements (excluding wire spacing and fence height) for 12.5 gage wire as per ASTM A 116. Space horizontal and vertical wire or closer as shown on this detail.

Furnish Tines molded in one piece of steel with no welds.

Furnish structural steel tubes with a wall thickness of 0.1875" and a unit weight of 4.32 lbs/ft.

Galvanize all tines, structural steel tubes, support plates, hinges, and top braces according to Standard Specifications [4154.10](#).

Refer to [MI-103](#) for layouts of brace posts.

Refer to [MI-103](#) for details of channel crossing installation and termination of fencing at structures.

Measurement of deer fence includes all brace panels but not deer gates.

Possible Tabulation:
[100-7](#)

 Iowa Department of Transportation	REVISION	
	New	04-20-10
STANDARD ROAD PLAN		MI-104
		SHEET 1 of 3

REVISIONS: New. Replaces 510-4(1),(2),(3).

Deanna McFalls
APPROVED BY DESIGN METHODS ENGINEER

DEER FENCE CONSTRUCTION

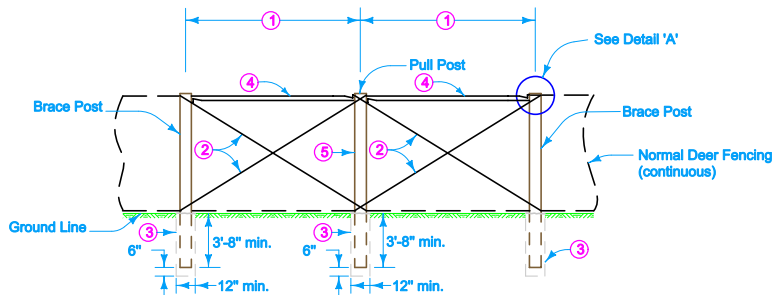

PULL POST ASSEMBLY

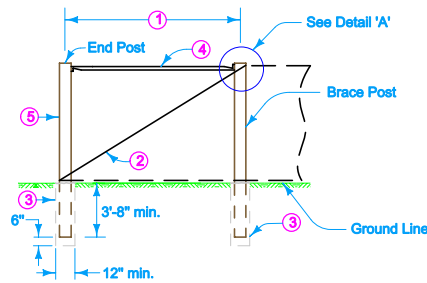

END POST INSTALLATION

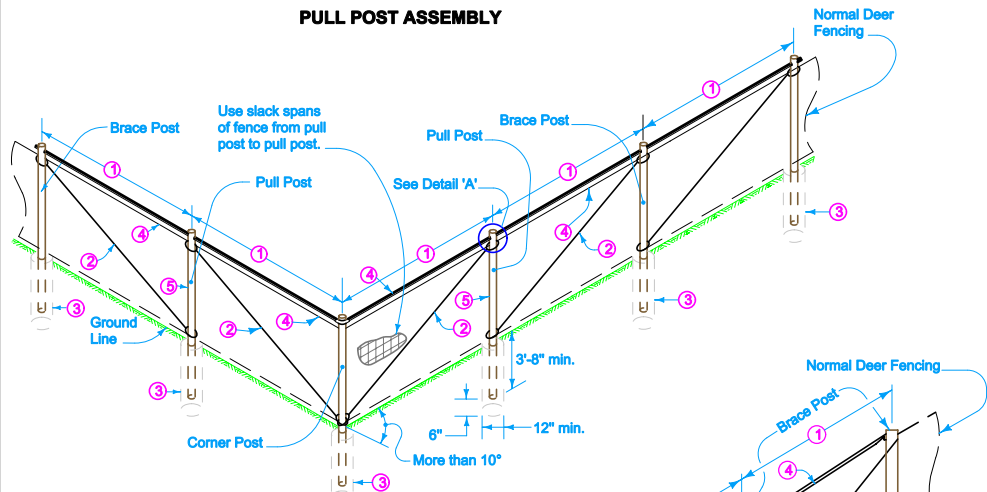

CORNER POST ASSEMBLY

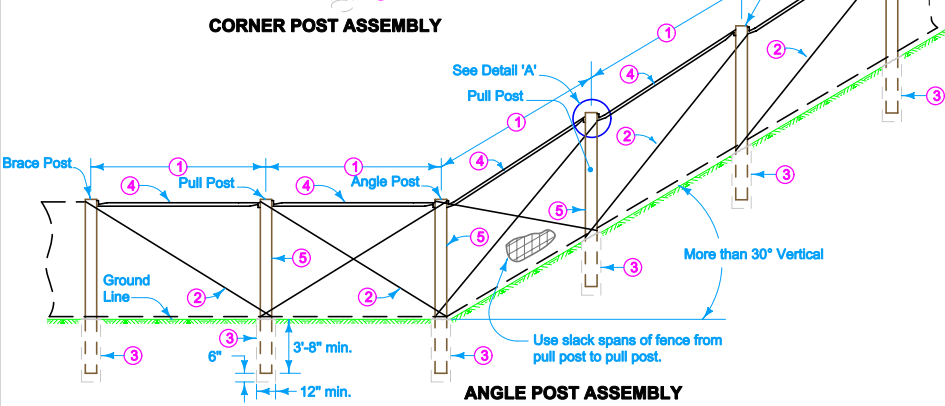

ANGLE POST ASSEMBLY

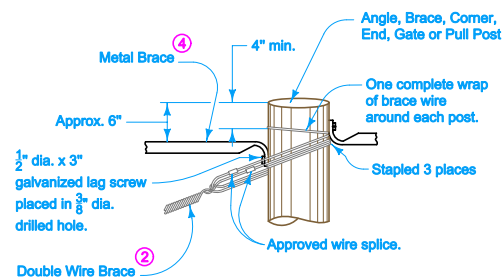

DETAIL 'A' BRACE WIRE INSTALLATION

(Brace wire wrapped the same at the bottom of post.)

- 1 Brace Panel.
- 2 Brace wire: 4 strands of No. 9 wire.
- 3 Details indicate placement of granular material for certain posts. Posts may be driven if satisfactory method is demonstrated to the Engineer. Granular material will not be required for driven posts.
- 4 Metal Brace 8 feet long.
- 5 Wrap wire fabric around post.
- 6 Twist the two brace wires together to produce proper tension in the brace assembly.

 Iowa Department of Transportation	REVISION New 04-20-10
	MI-104 SHEET 2 of 3
REVISIONS: New. Replaces 510-4(1),(2),(3).	
<i>Deanna McFalls</i> APPROVED BY DESIGN METHODS ENGINEER	
DEER FENCE CONSTRUCTION	

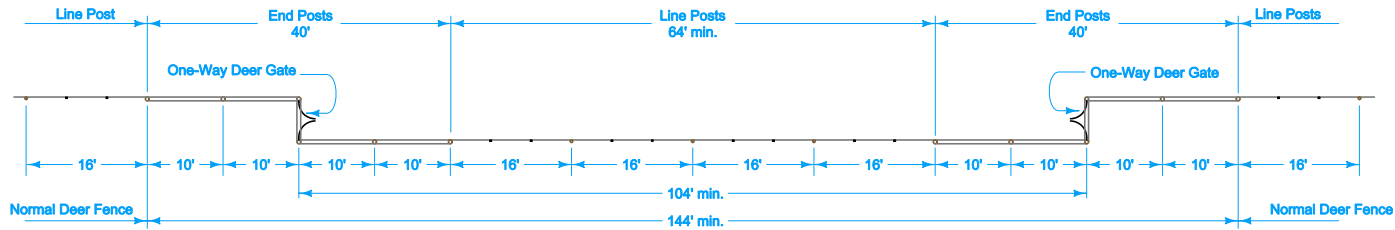

GATE PLAN

- ⑦ Spring loaded hinge allows tines to spread apart and return to original position.
- ⑧ Two 2 in. x 2 in. x $\frac{1}{8}$ in. L top braces held by $\frac{1}{2}$ inch diameter bolts.
- ⑨ Attach nut and washer to each bolt.
- ⑩ Support Plate 3 in. x $\frac{5}{8}$ in. x 37 in.
- ⑪ 2 in. x 2 in. x 54 in. structural steel tubing welded to Hinge Plate.
- ⑫ $\frac{3}{4}$ in. diameter x 8 in. bolt welded to Support Plate

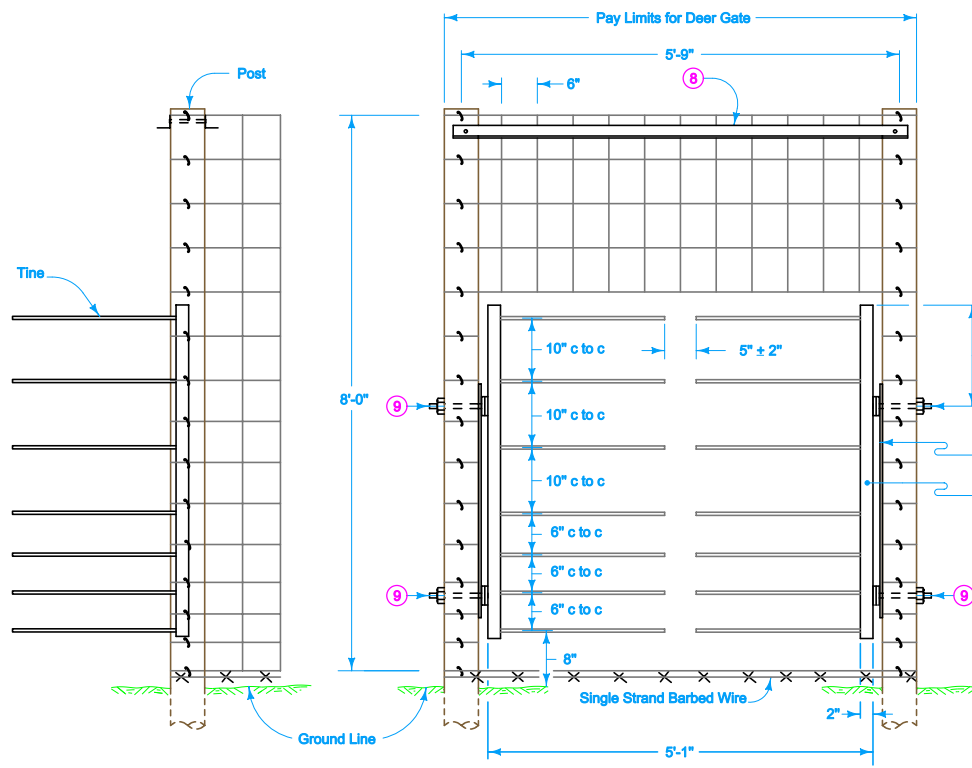

SECTION A-A

GATE FRONT

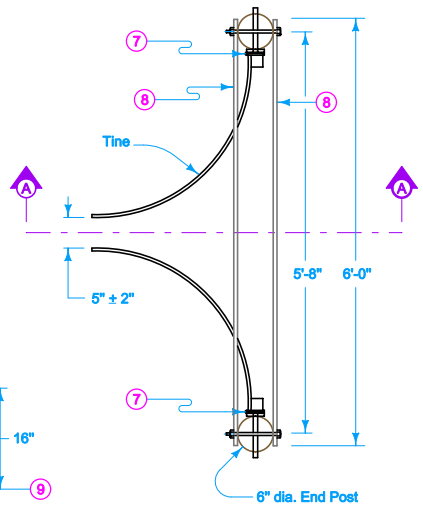

GATE TOP

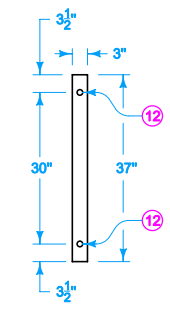

SUPPORT PLATE

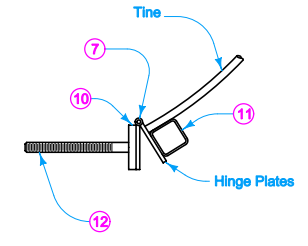

HINGE

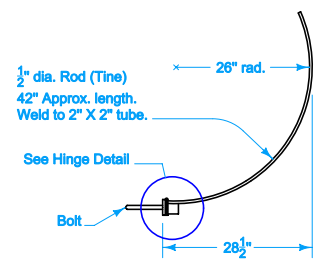

TINE

<p>Iowa Department of Transportation</p>	REVISION
	New 04-20-10
STANDARD ROAD PLAN	MI-104
REVISIONS: New. Replaces 510-4(1),(2),(3).	SHEET 3 of 3
<i>Deanna McFalls</i> APPROVED BY DESIGN METHODS ENGINEER	
DEER FENCE CONSTRUCTION	