

ELEVATION

Use Grade 60 epoxy-coated reinforcing bars. Provide 2 inches minimum cover. Anchor all reinforcement to prevent movement. Secure each section at the front, back, and at 3'-6" intervals using a method approved by the Engineer.

- ① Expansion joints are necessary only where specifically required by project plans. Conform expansion material to the shape of the barrier. No sealer is required.
- ② Where abutting sections are placed as separate pours, a butt joint may be used. Extend longitudinal reinforcement into the abutting section a minimum of 1'-6".
- ③ For barrier dowelled to pavement, match pavement joints. For free-standing barrier with integral footings, use 20 foot maximum, 15 foot minimum joint spacing.
- ④ Use 1 inch diameter deformed dowel bars of sufficient length to ensure 6 inch minimum embedment in barrier and supporting surface. Install dowels either in supporting surface when placed, or in drilled holes using polymer grout complying with Materials I.M. 491.11 or hydraulic cement grout complying with Materials I.M. 491.13.

- ⑤ Fillet all exposed corners with a $\frac{3}{4}$ inch dressed and beveled strip.
- ⑥ Construct concrete footing when barrier is not placed on concrete slab. Apply Section 2403.03, but the use of forms is optional. If forms are used, place backfill around the completed footing.
- ⑦ Place barrier markers at 100 foot increments in areas with non-continuous lighting, or 250 foot increments in areas with continuous lighting. Marker color to be the same as adjacent edge line.

Possible Contract Item:
Concrete Barrier, BA-102 or
Concrete Barrier, BA-102 and Footing

Possible Tabulation:
108-18B

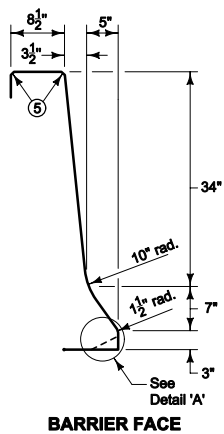

BARRIER FACE

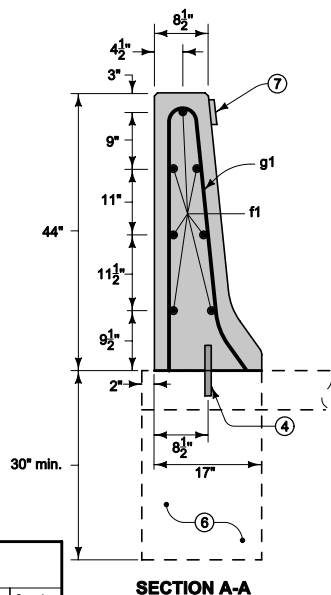

SECTION A-A

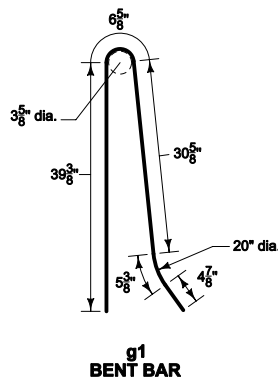

g1 BENT BAR

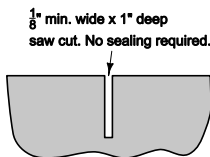

SAWED CONTRACTION JOINT

Saw cut top and front face. Saw cut back if exposed.

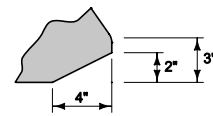

DETAIL 'A'

Special Shaping for Barrier over Intake

CONCRETE QUANTITIES Per foot 0.11 cy

REINFORCING BAR LIST Per Section (Approx. 20 feet)					
Bar	Size	Number of Bars	Length	Weight (lbs.)	Spacing
g1	5	14	5'-8"	83	1'-6"
f1	5	5	19'-6"	98	—

<p>Iowa Department of Transportation</p> <p>STANDARD ROAD PLAN</p> <p>REVISIONS: New. Replaces RE-44C.</p>	<p>REVISION</p> <p>New 04-20-10</p>
	<p>BA-102</p> <p>SHEET 1 of 1</p>

Deanna McFalls
APPROVED BY DESIGN METHODS ENGINEER

**44" CONCRETE BARRIER
(HALF SECTION)**