

AT JOINT INTERSECTION

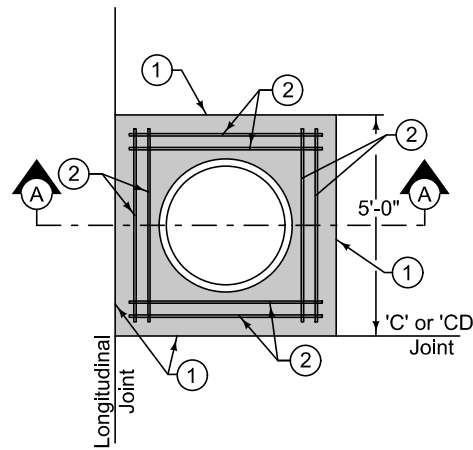

OFFSET AT JOINT INTERSECTION

Construct boxout with Class C concrete or match pavement class. Minimum 2 inches clear on reinforcement. Center casting within boxout area.

- ① 'KT-1', 'KT-2', 'BT-1', or 'BT-2' joint if three-piece floating casting (SW 601 Type B and D or SW-602 Type F) is used. 'E' joint if two-piece fixed casting (SW 601 Type A and C or SW-602 Type E) is used.
- ② 4 foot 8 inch (typ.) #4 bar. Place at mid-slab.
- ③ #4 hoops (variable length). Place at mid-slab.
- ④ No boxout is required for three-piece floating castings (SW 601 Type B and D or SW-602 Type F). If a boxout is used with a three-piece casting, construct as detailed in Section A-A for three-piece floating casting.

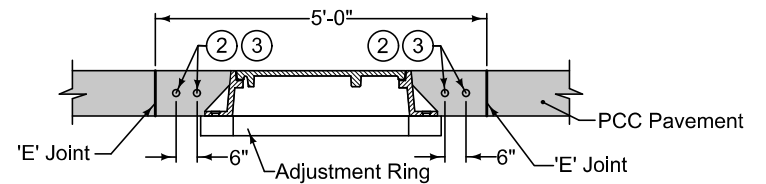

SECTION A-A  
(For two-piece fixed casting)

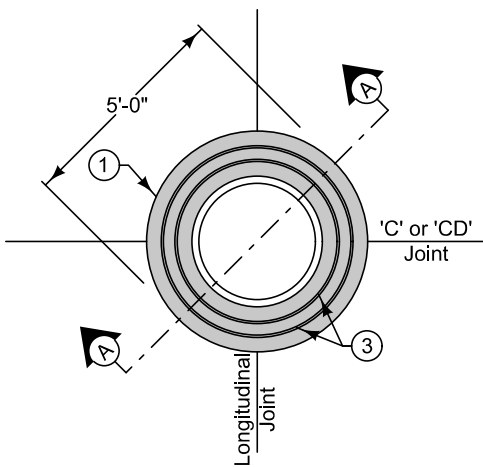

CIRCULAR

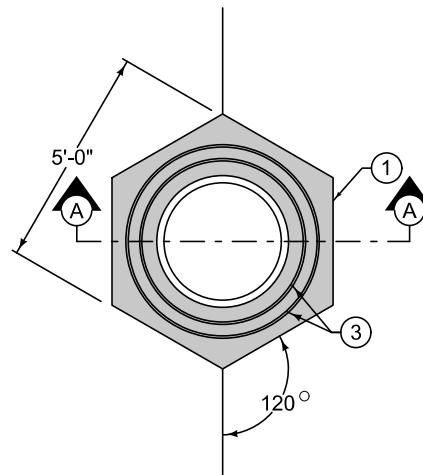

AT A SINGLE JOINT

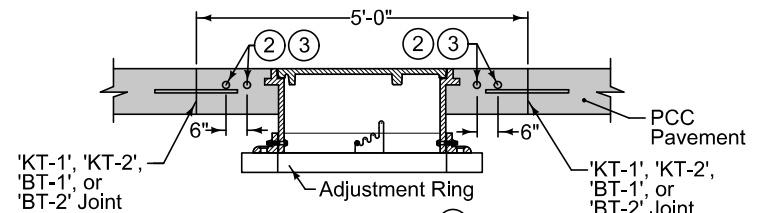

SECTION A-A ④  
(For three-piece floating casting)

FIGURE 7010.103 SHEET 1 OF 1

SUDAS Iowa Department of Transportation	REVISION
	New 04-19-11
FIGURE 7010.103	STANDARD ROAD PLAN
Paul D. Wiegand Deanna Markfeld <small>SUDAS DIRECTOR DESIGN METHODS ENGINEER</small>	
<b>PV-103</b> SHEET 1 of 1	

REVISIONS: New. Joint Standard with SUDAS.

MANHOLE BOXOUTS IN  
PCC PAVEMENT