

DETAIL 'A'

For joint details, see PV-101.
For curb details, see PV-102.

All Transverse Bars are #5.

See RK-21 or RK-22 for shoulders.

- ① 2" to 2½" clear to bent bar.
- ② Minimum lap length: #5 bars - 18 inches
#6 bars - 27 inches
#8 bars - 48 inches
- ③ If bridge is skewed, place additional #5 bar parallel to skewed face.

Possible Contract Item:
Bridge Approach, RK-26

Possible Tabulation:
112-6

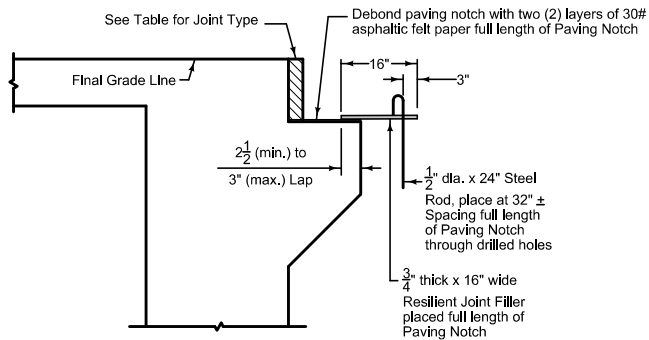

DETAIL 'B'

JOINT TYPE FOR MOVEABLE ABUTMENT BRIDGES		
Joint	Maximum Bridge Length	
	Concrete Beam or Slab	Steel Girder
CF-1	370'	250'
CF-2	465'	320'
CF-3	575'	400'

MOVEABLE ABUTMENT

 Iowa Department of Transportation	REVISION	
	7	10-18-11
	RK-26	
STANDARD ROAD PLAN		SHEET 1 of 4
<small>REVISIONS: Changed "U" bar size on sheets 1 and 2 from #5 to #4 to match sheet 4. Added circle note 9 and Detail 'G'. Changed curb.</small>		
<i>Deanna Macfild</i> <small>APPROVED BY DESIGN METHODS ENGINEER</small>		
DOUBLE REINFORCED 10" APPROACH WITH VARIABLE DEPTH PAVING NOTCH		

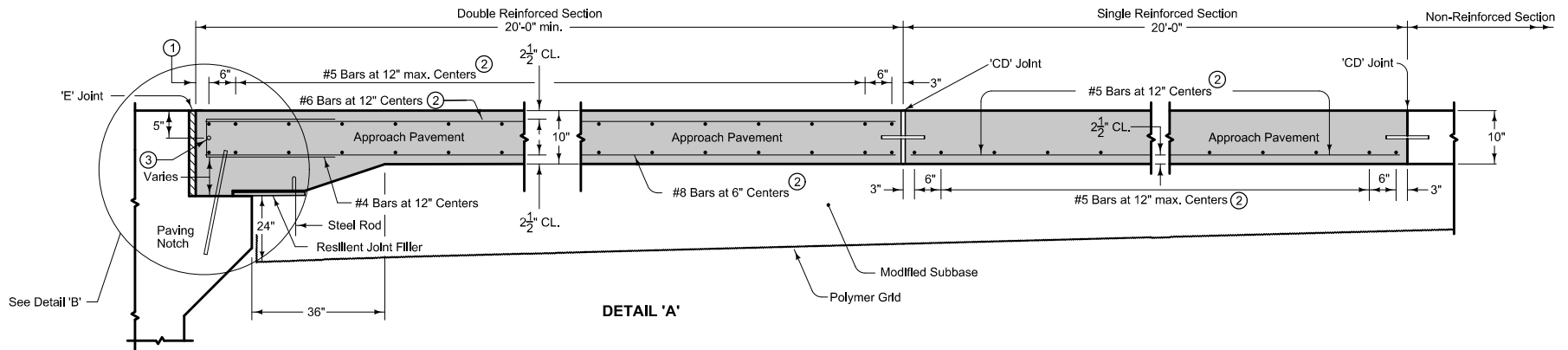

DETAIL 'A'

- ① 2" to 2½" clear to bent bar.
- ② Minimum lap length: #5 bars - 18 inches
#6 bars - 27 inches
#8 bars - 48 inches
- ③ If bridge is skewed, place additional #5 bar parallel to skewed face.

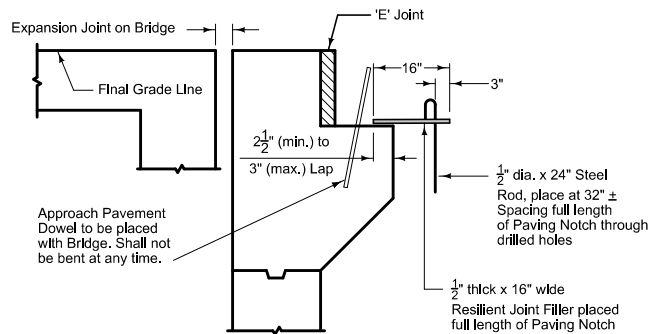

DETAIL 'B'

FIXED ABUTMENT

 Iowa Department of Transportation	REVISION	
	7	10-18-11
STANDARD ROAD PLAN		RK-26
		SHEET 2 of 4
REVISIONS: Changed "U" bar size on sheets 1 and 2 from #5 to #4 to match sheet 4. Added circle note 9 and Detail 'G'. Changed curb.		
<i>Deanna Macfadyen</i> APPROVED BY DESIGN METHODS ENGINEER		
DOUBLE REINFORCED 10" APPROACH WITH VARIABLE DEPTH PAVING NOTCH		

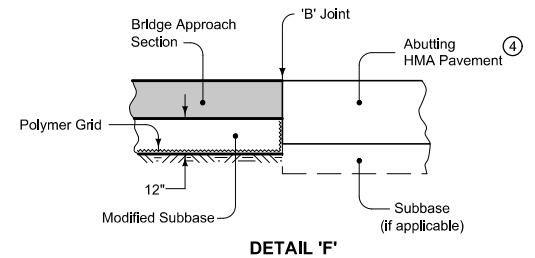
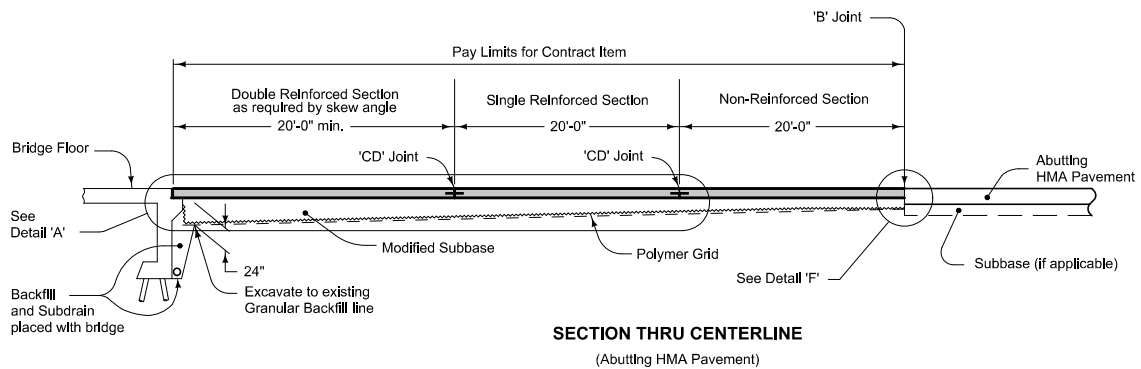
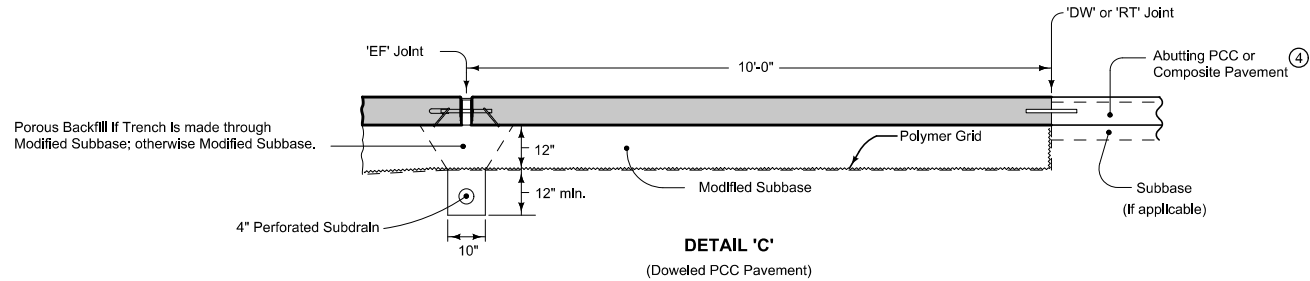
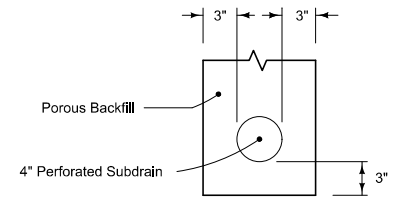
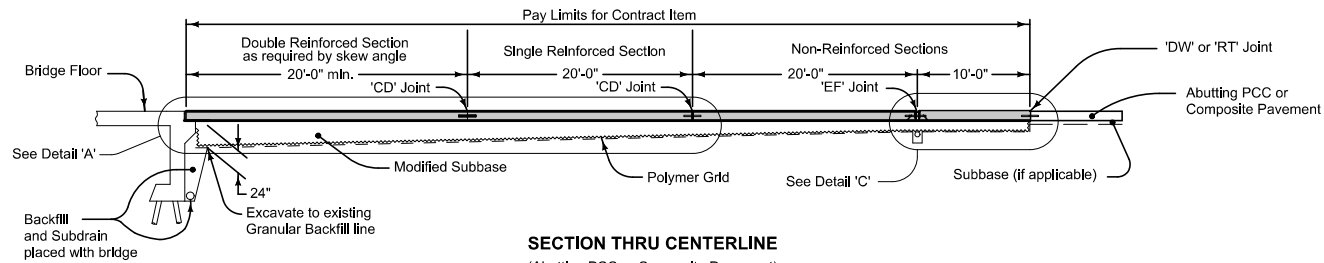

 Iowa Department of Transportation	REVISION
	7 10-18-11
STANDARD ROAD PLAN	RK-26
	SHEET 3 of 4

REVISIONS: Changed "U" bar size on sheets 1 and 2 from #5 to #4 to match sheet 4. Added circle note 9 and Detail 'G'. Changed curb.

Deanna Macfild
APPROVED BY DESIGN METHODS ENGINEER

④ If abutting pavement (PCC or HMA) is not in place, see RK-30.

**DOUBLE REINFORCED 10" APPROACH
WITH VARIABLE DEPTH PAVING NOTCH**

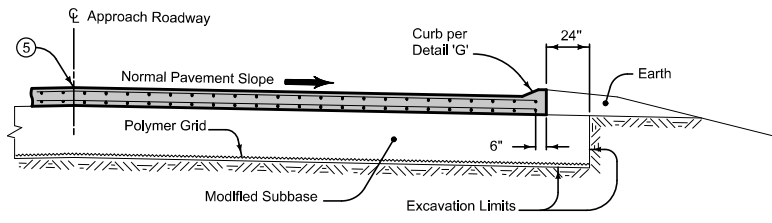

SECTION A-A ^⑥

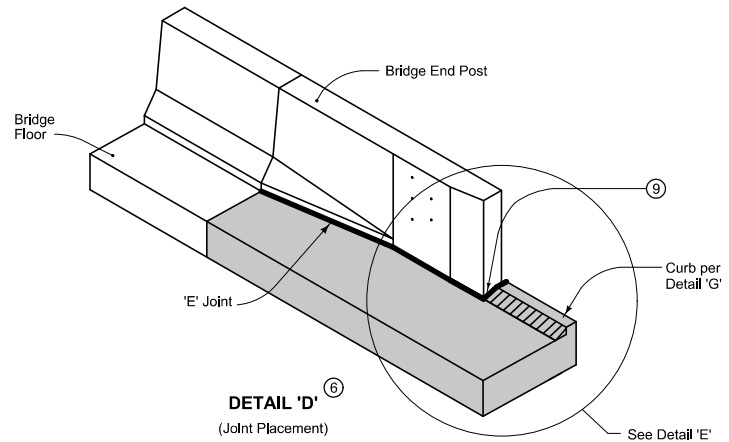

DETAIL 'D' ^⑥
(Joint Placement)

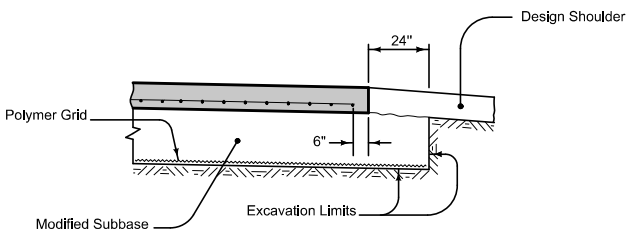

SECTION B-B ^⑥

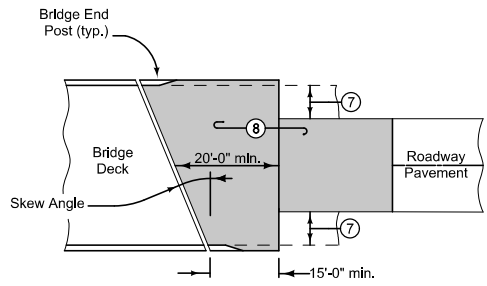

APPROACH PAVEMENT LAYOUT AT A SKEW

- ⑤ Longitudinal Joint: (PV-101)
Single pour - Saw cut joint per Detail B
Two pours - use 'KS-2' Joint
 - ⑥ See RK-21, RK-22, or RK-23.
 - ⑦ Design shoulder width.
 - ⑧ Reinforced bridge approach section.
 - ⑨ Expansion joint at end of bridge end post: Place joint filler the full depth of the bridge approach pavement. In areas with curb, place full depth of pavement plus curb and shape material to fit the shape of the curb per Section B-B of PV-101. Seal joint per Detail F of PV-101.
- Fixed Abutment Bridges: Type 'E' Joint
- Moveable Abutment Bridges: Flexible Foam Expansion Joint Filler in accordance with Specification Section 4136. Minimum filler width is the abutment 'CF' joint width. Joint length as required to completely fill from back side of curb to front face of bridge wing.

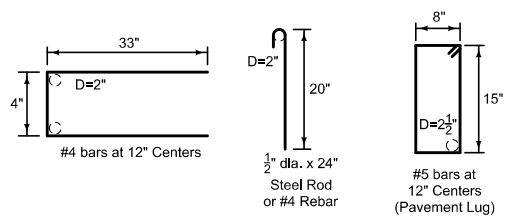

BENT BAR SHAPES

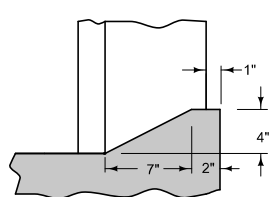

DETAIL 'G'

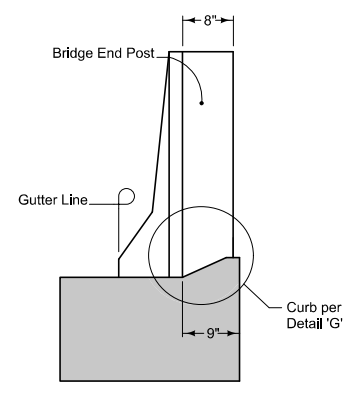

DETAIL 'E'
(Back of Curb Placement)

 Iowa Department of Transportation	REVISION	
	7	10-18-11
	STANDARD ROAD PLAN	
RK-26		SHEET 4 of 4
<small>REVISIONS: Changed "U" bar size on sheets 1 and 2 from #5 to #4 to match sheet 4. Added circle note 9 and Detail 'G'. Changed curb.</small>		
<i>Deanna Macfild</i> <small>APPROVED BY DESIGN METHODS ENGINEER</small>		

DOUBLE REINFORCED 10" APPROACH WITH VARIABLE DEPTH PAVING NOTCH