

| H<br>IN<br>FT. | CL - CL<br>ABUT. BRG. | PILING<br>NO. &<br>LAYOUT | DES. BRG.<br>(TONS) | FOOTING SIZE   |
|----------------|-----------------------|---------------------------|---------------------|----------------|
| 20'-4          | 10D                   | 47                        |                     |                |
| 21'-10         | 10D                   | 48                        |                     | 4' x 9' x 22'  |
| 22'-4          | 10D                   | 50                        |                     |                |
| 24'-0          | 11B                   | 48                        |                     |                |
| 20'-4          | 10E                   | 48                        |                     |                |
| 21'-10         | 10E                   | 49                        |                     | 4' x 9' x 24'  |
| 22'-4          | 10E                   | 50                        |                     |                |
| 24'-0          | 11C                   | 48                        |                     |                |
| 20'-4          | 11D                   | 46                        |                     |                |
| 21'-10         | 11D                   | 47                        |                     | 4' x 10' x 24' |
| 22'-4          | 11D                   | 49                        |                     |                |
| 24'-0          | 11D                   | 50                        |                     |                |
| 20'-4          | 12A                   | 43                        |                     |                |
| 21'-10         | 12A                   | 44                        |                     | 4' x 13' x 22' |
| 22'-4          | 12A                   | 45                        |                     |                |
| 24'-0          | 12A                   | 46                        |                     |                |
| 20'-4          | 12A                   | 45                        |                     |                |
| 21'-10         | 12A                   | 46                        |                     | 4' x 13' x 22' |
| 22'-4          | 12A                   | 47                        |                     |                |
| 24'-0          | 12A                   | 48                        |                     |                |

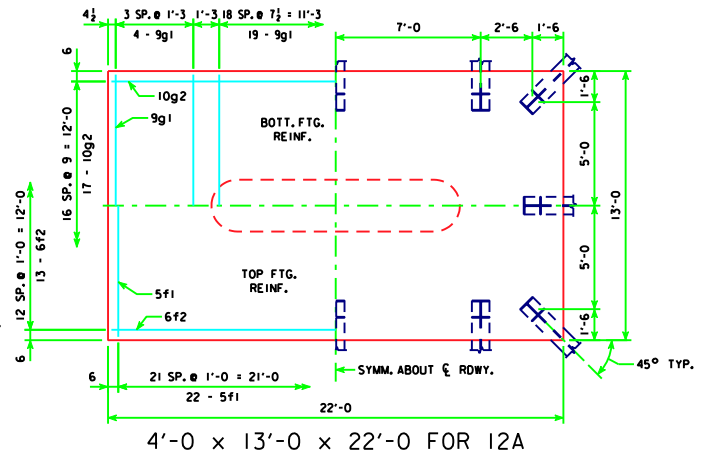

| FOOTING SIZE   | REINFORCING STEEL (ONE FOOTING) |                     |        | TOTAL WEIGHT (L.B.) | STRUCTURAL CONCRETE (CY) |      |
|----------------|---------------------------------|---------------------|--------|---------------------|--------------------------|------|
|                | BAR                             | NO., SIZE & SPACING | LENGTH |                     |                          |      |
| 4' x 9' x 22'  | d2                              | 30 - #9 AS SHOWN    | 9'-1   | 926                 | 3091                     | 29.3 |
|                | f1                              | 22 - #5 @ 1'-0      | 8'-8   | 199                 |                          |      |
|                | f2                              | 9 - #6 @ 1'-0       | 21'-8  | 293                 |                          |      |
|                | g1                              | 26 - #7 AS SHOWN    | 8'-8   | 461                 |                          |      |
|                | g2                              | 13 - #10 @ 0'-8 1/2 | 21'-8  | 1212                |                          |      |
|                | d2                              | 30 - #9 AS SHOWN    | 9'-1   | 926                 |                          |      |
| 4' x 9' x 24'  | f1                              | 24 - #5 @ 1'-0      | 8'-8   | 217                 | 3792                     | 32.0 |
|                | f2                              | 9 - #6 @ 1'-0       | 23'-8  | 320                 |                          |      |
|                | g1                              | 28 - #7 AS SHOWN    | 8'-8   | 496                 |                          |      |
|                | g2                              | 18 - #10 @ 0'-6     | 23'-8  | 1833                |                          |      |
|                | d2                              | 30 - #9 AS SHOWN    | 9'-1   | 926                 |                          |      |
|                | f1                              | 24 - #5 @ 1'-0      | 9'-8   | 242                 |                          |      |
| 4' x 10' x 24' | f2                              | 11 - #6 @ 0'-11     | 23'-8  | 619                 | 4011                     | 35.6 |
|                | g1                              | 24 - #8 AS SHOWN    | 9'-8   | 619                 |                          |      |
|                | g2                              | 18 - #10 @ 0'-6 1/2 | 23'-8  | 1833                |                          |      |
|                | d2                              | 30 - #9 AS SHOWN    | 9'-1   | 926                 |                          |      |
|                | f1                              | 24 - #5 @ 1'-0      | 9'-8   | 242                 |                          |      |
|                | f2                              | 11 - #6 @ 0'-11     | 23'-8  | 619                 |                          |      |
| 4' x 13' x 22' | f1                              | 22 - #5 @ 1'-0      | 12'-8  | 291                 | 4388                     | 42.4 |
|                | f2                              | 13 - #6 @ 1'-0      | 21'-8  | 423                 |                          |      |
|                | g1                              | 27 - #9 AS SHOWN    | 12'-8  | 1163                |                          |      |
|                | g2                              | 17 - #10 @ 0'-9     | 21'-8  | 1585                |                          |      |
|                | d2                              | 30 - #9 AS SHOWN    | 9'-1   | 926                 |                          |      |
|                | f1                              | 22 - #5 @ 1'-0      | 12'-8  | 291                 |                          |      |

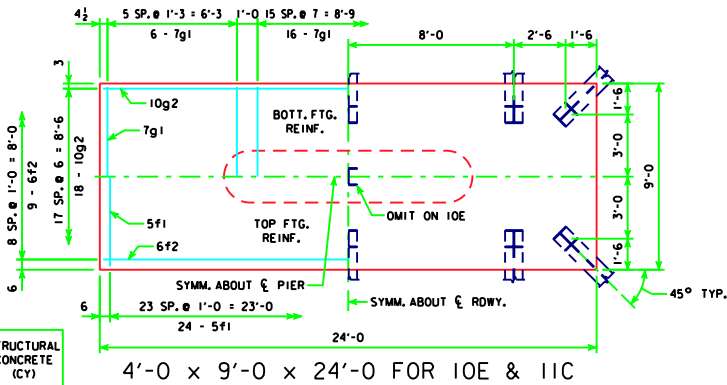
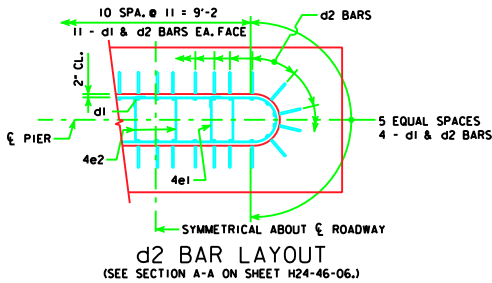

NOTE:  
SEE SHEET H24-47-06 FOR FOOTING NOTES.

|                      |                                 |   |           |  |
|----------------------|---------------------------------|---|-----------|--|
| LATEST REVISION DATE | <br>APPROVED BY BRIDGE ENGINEER | <br><b>Iowa Department of Transportation</b><br>Highway Division  | H24-48-06 |  |
|                      |                                 | STANDARD DESIGN - 24' ROADWAY, THREE SPAN BRIDGE<br><b>PRETENSIONED PRESTRESSED CONCRETE BEAM BRIDGES</b> |           |  |
|                      |                                 | HL93 SUPERSTRUCTURE    DECEMBER, 2006    HS25 SUBSTRUCTURE  |           |  |
|                      |                                 | <b>TEE PIER - STEEL PILE FOOTINGS, H=25' TO 40'</b><br>0° SKEW  |           |  |