

SHOULDERS

2 LANE

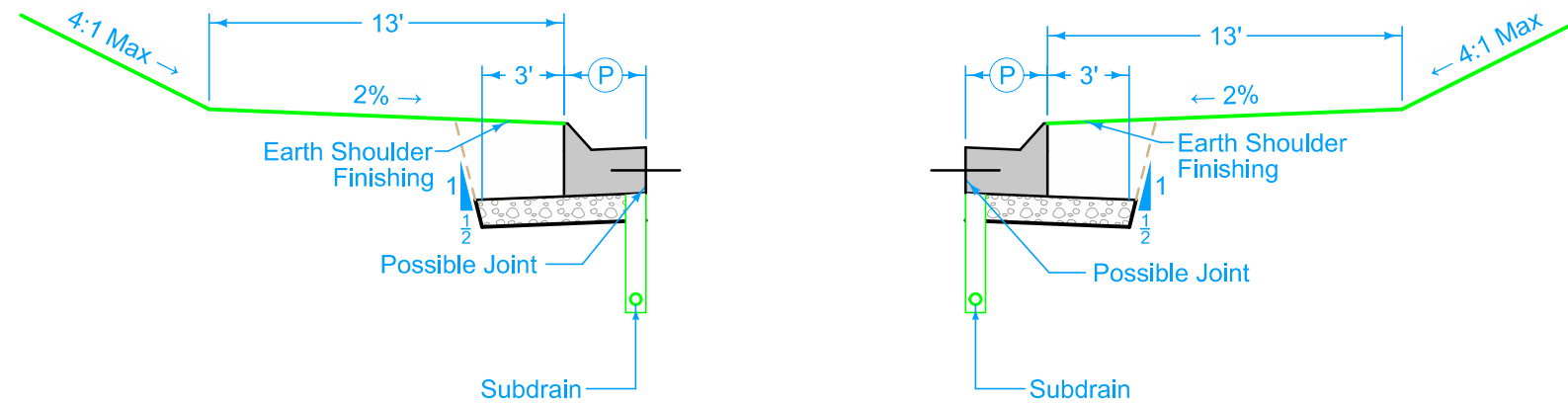

Curbed Shoulder

Shoulder Jointing:
 Longitudinal joint not required when distance from back of curb to nearest joint is less than 15':

Single pour: L-2
 Staged : BT-2
 Transverse: C at 17' spacing

		2_Curb_ 04-15-25	
STATION TO STATION	(P) Feet	Curb Type See PV-102	