

SHOULDERS RAMPS

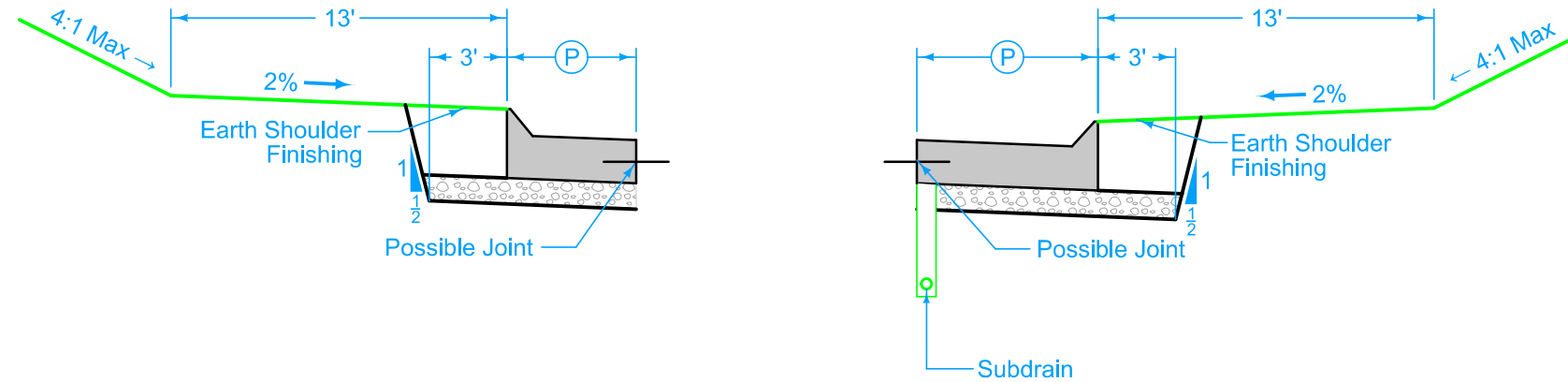

Curbed Shoulder

Shoulder jointing:
 Longitudinal joint not required when distance from back of curb to nearest joint is less than 16':

Transverse: C at 15' spacing
 Single pour: L-2
 Staged : BT-2

			1R_Curb_ 04-15-25
BEGIN STATION	END STATION	(P) Feet	Curb Type See PV-102