

TYPICAL SECTION

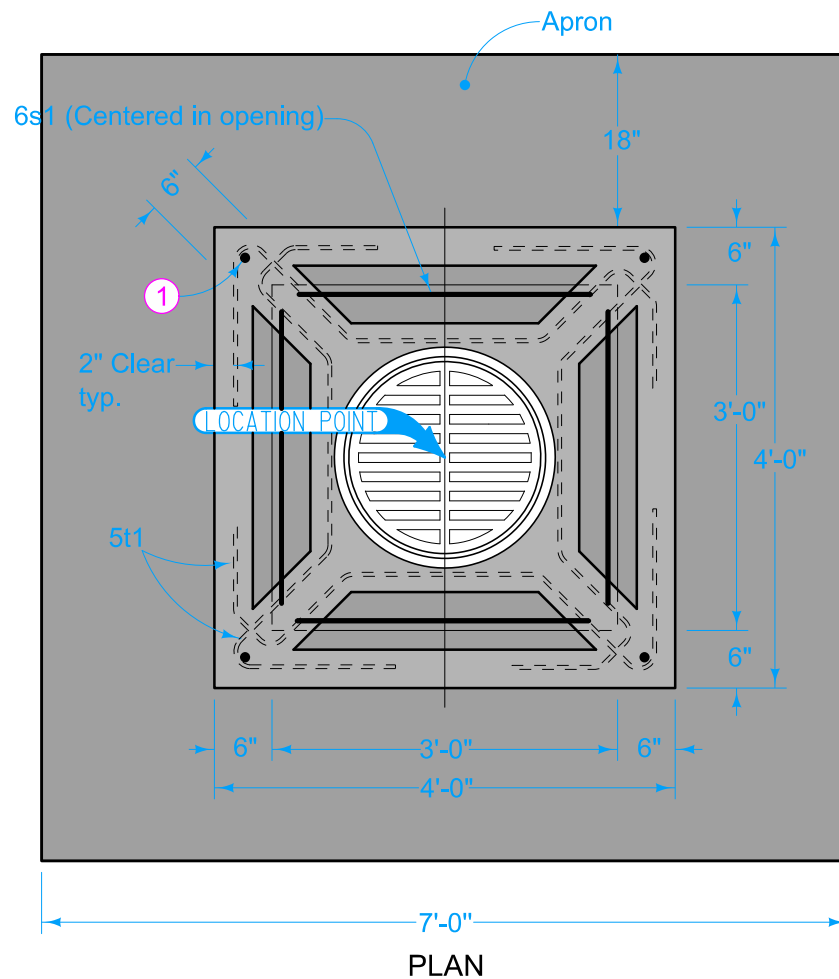

PLAN

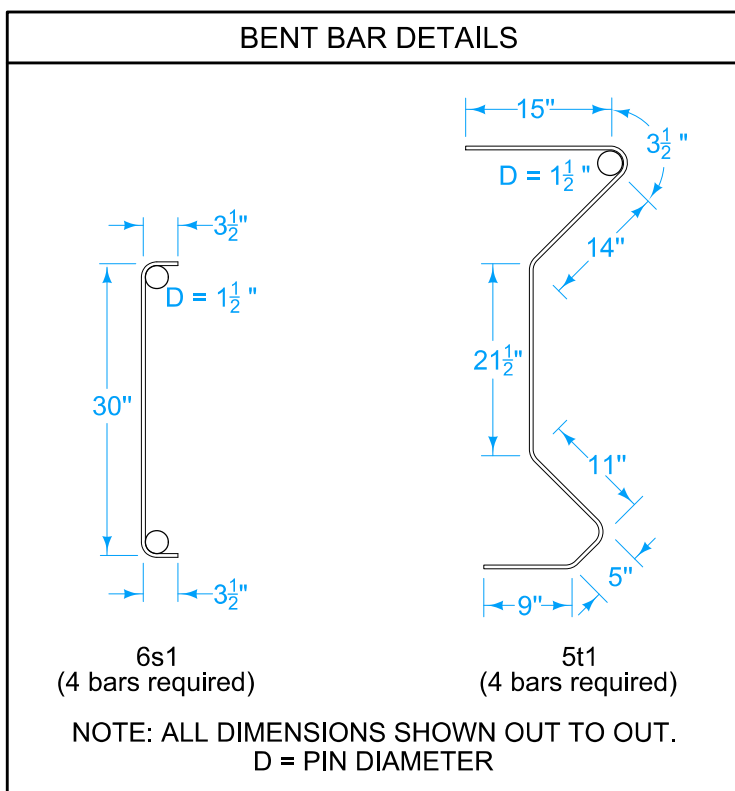

6s1
(4 bars required)

5t1
(4 bars required)

NOTE: ALL DIMENSIONS SHOWN OUT TO OUT.
D = PIN DIAMETER

Top of intake may be poured in the field or precast. For precast units, place a 1 inch diameter X 3 inch deep alignment hole 3 inches from each side of the corners of the unit.

Maximum pipe size 18 inches.

- ① Four #6 X 9 inch alignment pins (precast tops only).
- ② 12 inch minimum wall height above all pipes.

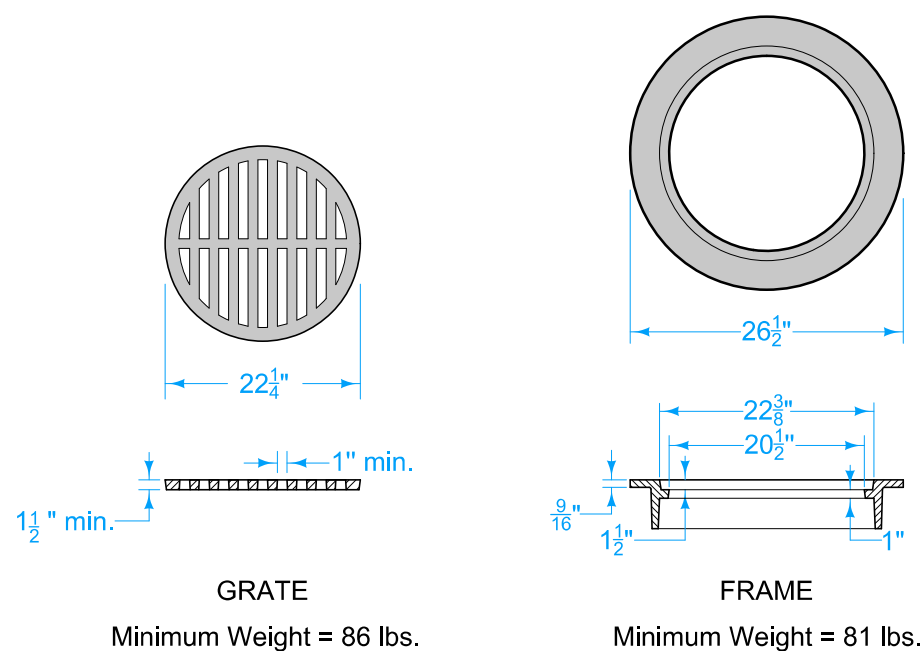

GRATE

Minimum Weight = 86 lbs.

FRAME

Minimum Weight = 81 lbs.

 STANDARD ROAD PLAN	REVISION	
	3	04-17-18
	SW-562	
SHEET 1 of 1		
REVISIONS: Changed the title. Added a Concrete Fillet. Added maximum pipe size.		
 APPROVED BY DESIGN METHODS ENGINEER		
VERTICAL THROAT AREA INTAKE (SMALL BOX)		