

Adjacent walls may have different widths based upon pipe configuration, but structure must be rectangular.

- ① Provide two #4 hoop bars at top opening and at all pipe openings.
- ② Cast-in-place base shown. If base is precast integral with walls, the footprint of the base is not required to extend beyond the outer edge of the walls.
- ③ Wall widths vary with pipe diameter and range from 4 feet minimum to 9 feet maximum. Provide 12 inches of wall width (minimum) each side of pipe opening.
- ④ 12 inch minimum wall height above all pipes.

TYPICAL SECTION

FIGURE 6010.403 SHEET 1 OF 2

SUDAS	IOWA DOT	REVISION	
		2	04-21-20
FIGURE 6010.403	STANDARD ROAD PLAN	SW-403	
		SHEET 1 of 2	

REVISIONS: Added Class I Bedding Material.

Paul D. Wrigans
 SUDAS DIRECTOR

Stuart Miller
 DESIGN METHODS ENGINEER

**DEEP WELL RECTANGULAR
STORM SEWER MANHOLE**

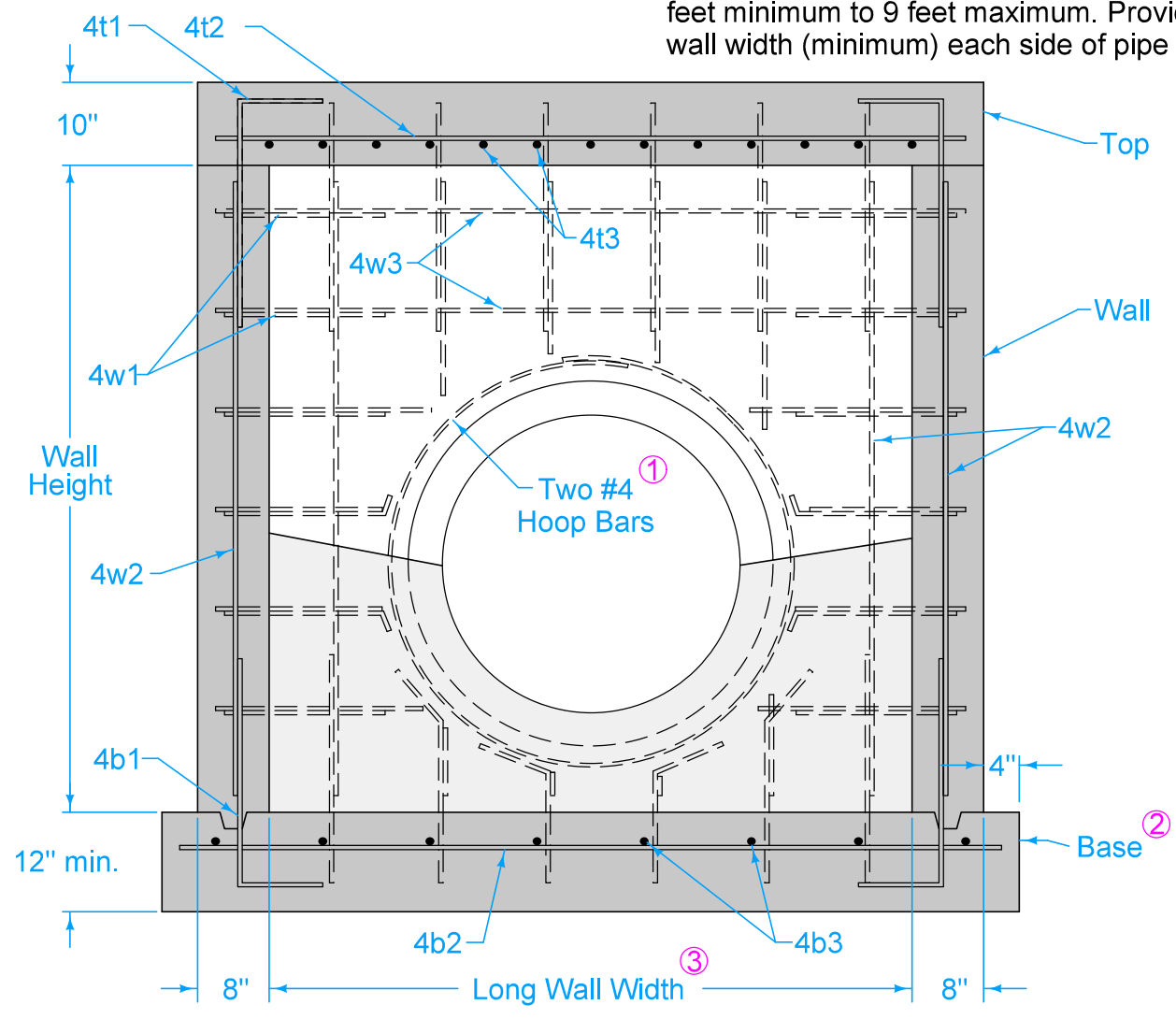
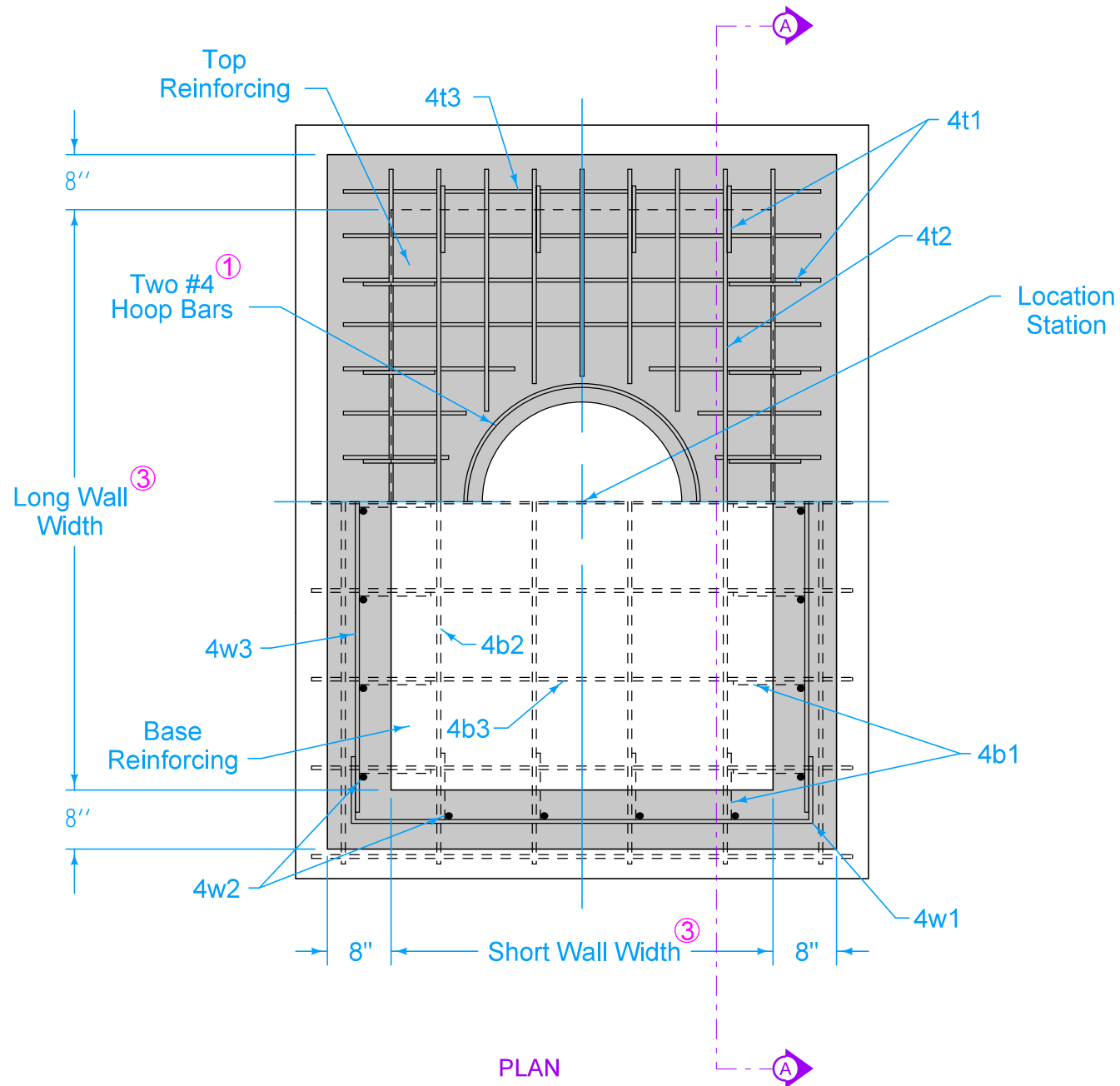

- ① Provide two #4 hoop bars at top opening and at all pipe openings.
- ② Cast-in-place base shown. If base is precast integral with walls, the footprint of the base is not required to extend beyond the outer edge of walls.
- ③ Wall widths vary with pipe diameter and range from 4 feet minimum to 9 feet maximum. Provide 12 inches of wall width (minimum) each side of pipe opening.

PLAN

SECTION A-A

REINFORCING BAR LIST					
Mark	Size	Location	Shape	Length	Spacing
4t1	4	Top	┌	36"	12"
4t2	4	Top	—	Long Wall plus 12"	6"
4t3	4	Top	—	Short Wall plus 12"	6"
4b1	4	Base	└	36"	12"
4b2	4	Base	—	Long Wall plus 18"	12"
4b3	4	Base	—	Short Wall plus 18"	12"
4w1	4	Walls	┌	Short Wall plus 48"	12"
4w2	4	Walls	—	Wall Height minus 4"	12"
4w3	4	Walls	—	Long Wall plus 12"	12"

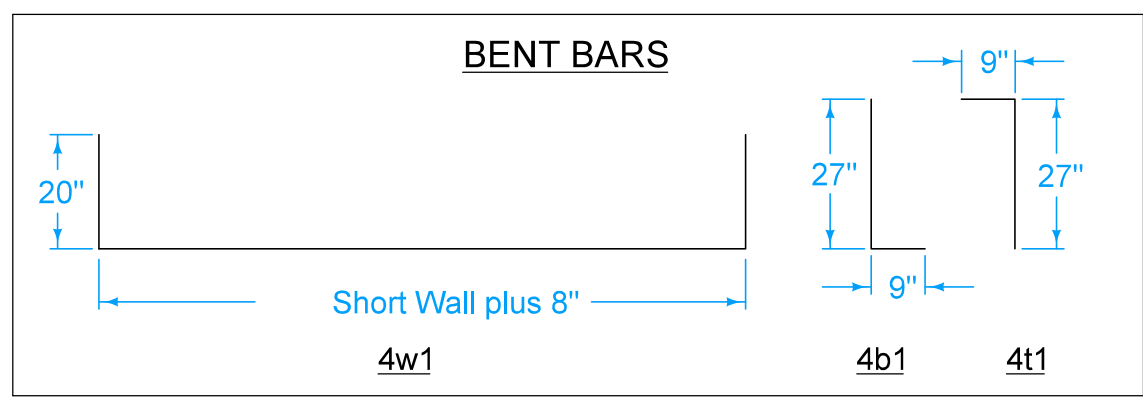

FIGURE 6010.403 SHEET 2 OF 2

SUDAS IOWA DOT FIGURE 6010.403 STANDARD ROAD PLAN	REVISION 2 04-21-20
	SW-403 SHEET 2 of 2
REVISIONS: Added Class I Bedding Material.	
<i>Paul D. Wiegand</i> SUDAS DIRECTOR	<i>Stuart Miller</i> DESIGN METHODS ENGINEER
DEEP WELL RECTANGULAR STORM SEWER MANHOLE	