

'W' and 'T' are specified by the individual project plans. Dimensions may vary for superelevated curves or at locations specifically designated by the Engineer.

For joint details, refer to PV-101 and PV-121.

Install contraction joints adjacent to all existing joints or at the interval specified on the plans. Extend existing expansion joint through the widening unit. This work is incidental to other work on the project.

Construct special shaping of widening units through bridge approach sections as directed by the Engineer. The joint between the widening unit and the end of a bridge consists of a 3 inch wide joint filled with full depth bituminous resilient filler as specified in Article 4136.03, A of the Standard Specifications

Excavation in excess of that indicated is incidental to other work on the project.

- ① 'BT-3' placed at mid-height unless noted otherwise.
- ② For ramps and superelevated curves, match the cross-slope of the widening unit to the existing pavement.
- ③ See Section 2514 (for Portland Cement Concrete Widening) or Section 2213 (for Base Widening) of the Standard Specifications.

Possible Contract Items:

- Portland Cement Concrete Pavement Widening
- Base Widening, Portland Cement Concrete
- Removal of Curb
- Removal of Flumes
- Shoulders
- Excavation, Class 13, For Widening
- Special Backfill

Possible Tabulations:

- 106-5
- 106-4
- 110-4
- 110-3

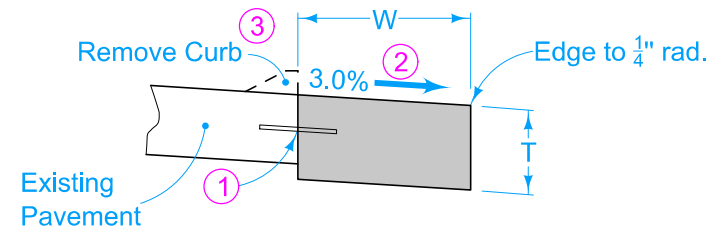

PAVEMENT WIDENING

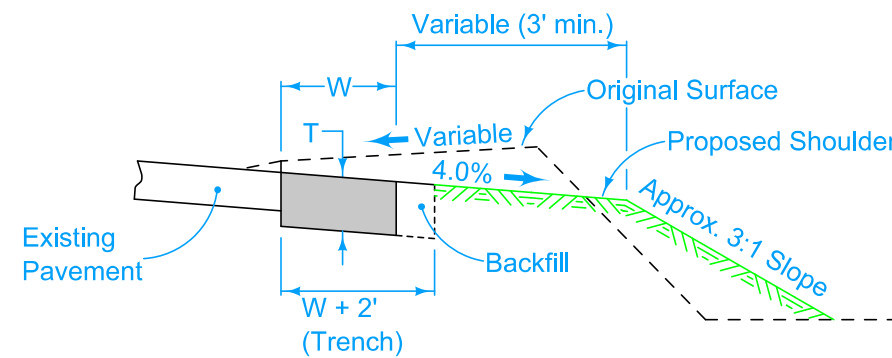

TYPE 'A'

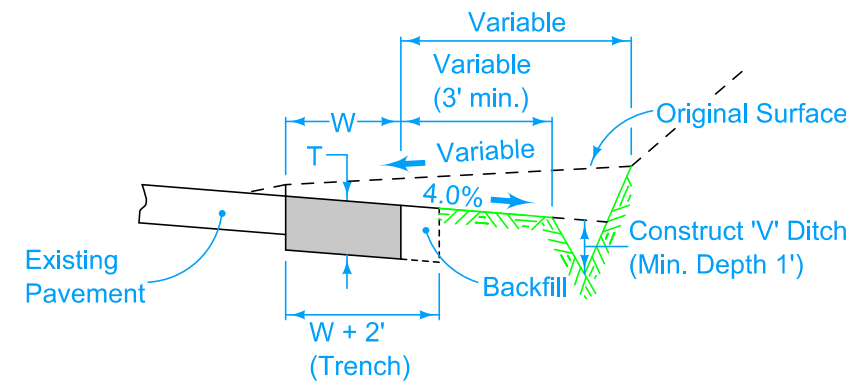

TYPE 'B'

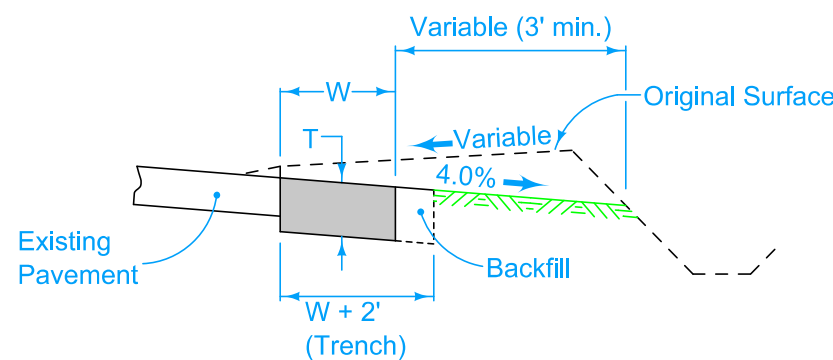

TYPE 'C'

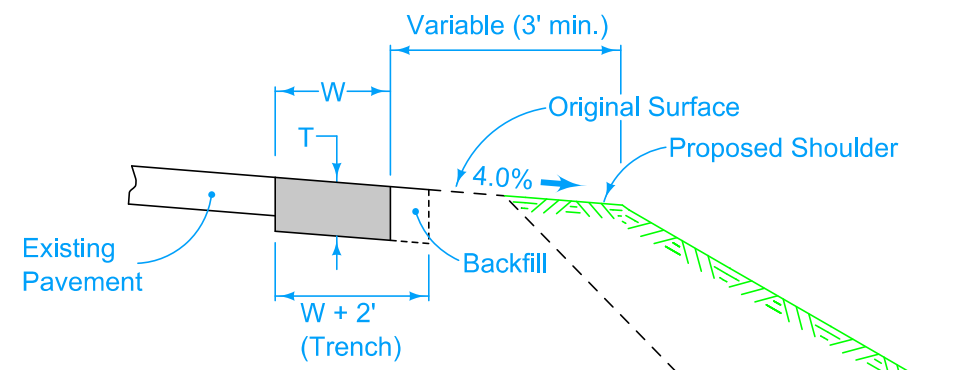

TYPE 'D'

SHOULDERS FOR PAVEMENT WIDENING

IOWA DOT	REVISION	
	2	10-21-14
STANDARD ROAD PLAN		PV-105
		SHEET 1 of 1

REVISIONS: Changed the P dimension to W in each of the drawings.

Shawn Miller
APPROVED BY DESIGN METHODS ENGINEER

PCC PAVEMENT WIDENING