

AT JOINT INTERSECTION

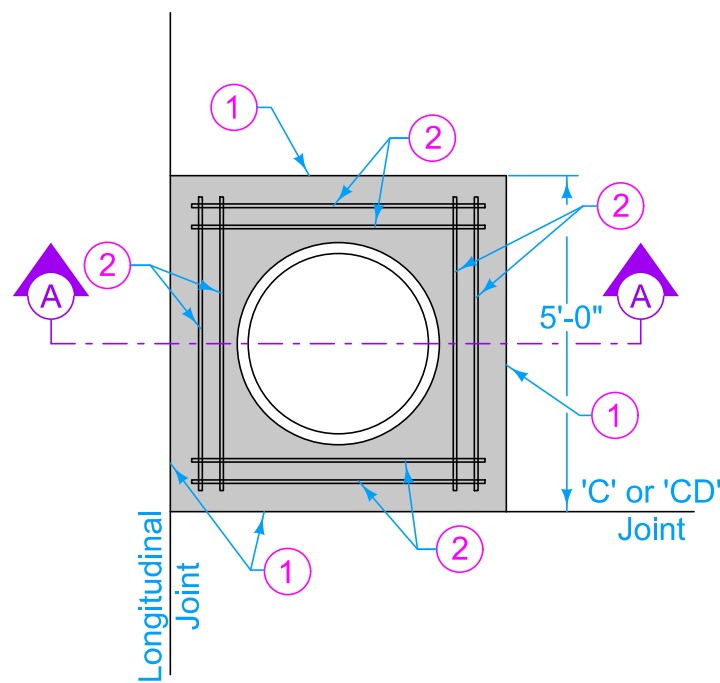

OFFSET AT JOINT INTERSECTION

Construct boxout with Class C concrete or match pavement class. Minimum 2 inches clear on reinforcement. Minimum 12 inches of concrete between outside of casting and nearest joint. Center casting within boxout area if possible.

- ① 'KT-1', 'KT-2', 'BT-1', or 'BT-2' joint if three-piece floating casting (SW 601 Type B and D or SW-602 Type F) is used. 'E' joint if two-piece fixed casting (SW 601 Type A and C or SW-602 Type E) is used.
- ② 4 foot 8 inch (typ.) #4 bar. Place at mid-slab.
- ③ #4 hoops (variable length). Place at mid-slab.
- ④ No boxout is required for three-piece floating castings (SW 601 Type B and D or SW-602 Type F). If a boxout is used with a three-piece casting, construct as detailed in Section A-A for three-piece floating casting.
- ⑤ If a circular boxout is cut and extracted after PCC construction, a 'B' joint may be substituted for the 'E' joint if approved by the Engineer.

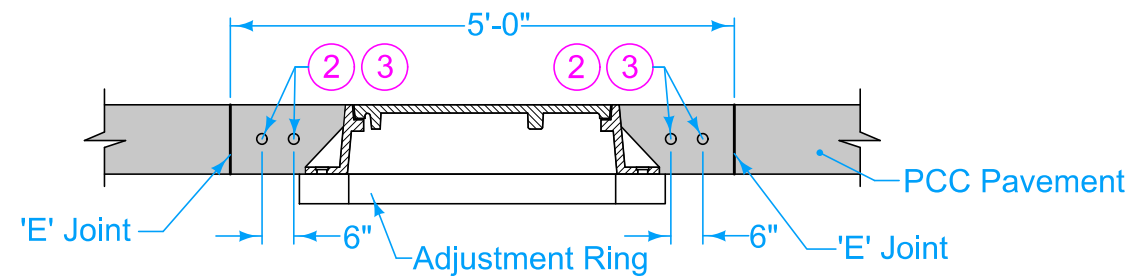

SECTION A-A
(For two-piece fixed casting)

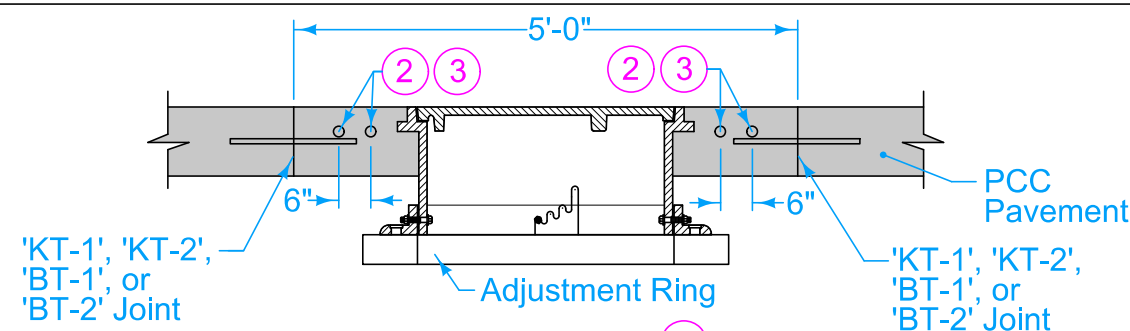

SECTION A-A ④
(For three-piece floating casting)

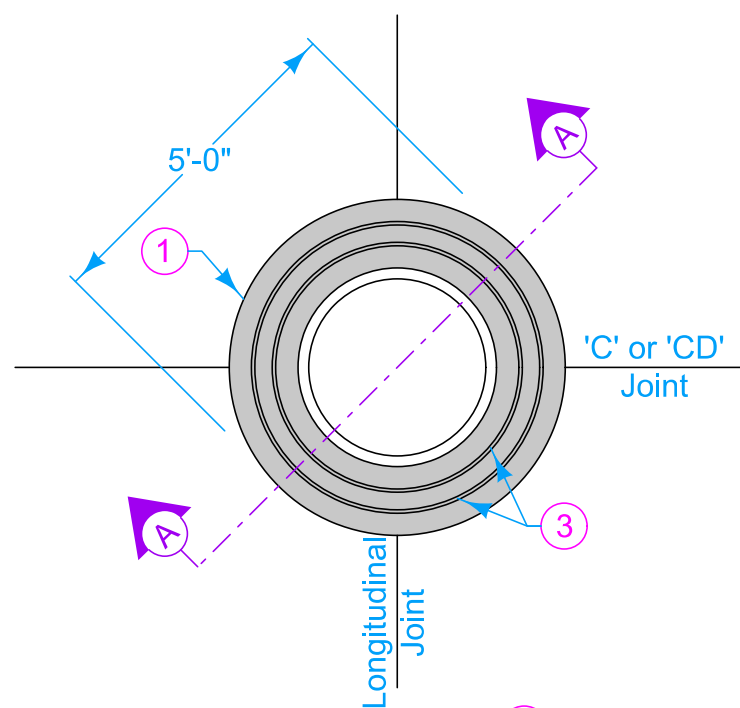

CIRCULAR

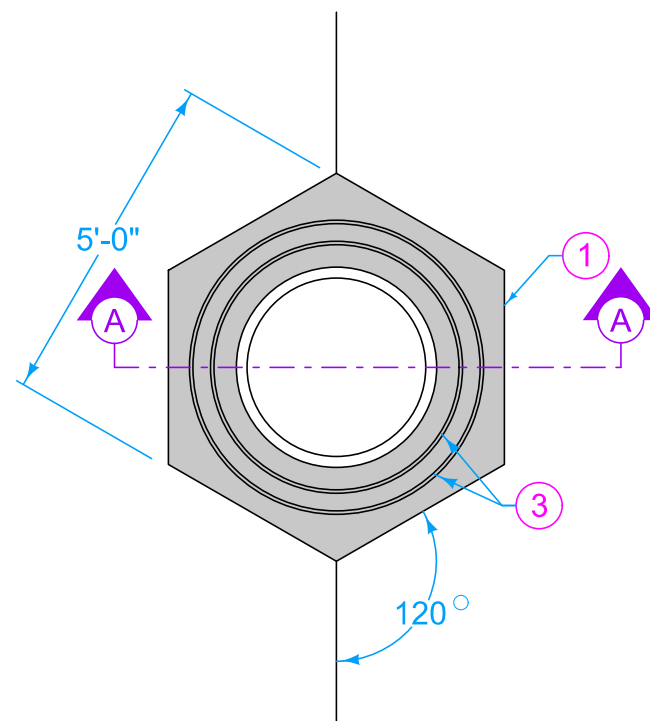

AT A SINGLE JOINT

SUDAS IOWA DOT	REVISION 2 04-19-22
	PV-103 SHEET 1 of 1
FIGURE 7010.103 STANDARD ROAD PLAN	REVISIONS: Added note 5.
<i>Paul D. Wrigand</i> SUDAS DIRECTOR	<i>Shawn Miller</i> DESIGN METHODS ENGINEER

MANHOLE BOXOUTS IN
PCC PAVEMENT