

FULL ROADWAY WIDTH PATCH

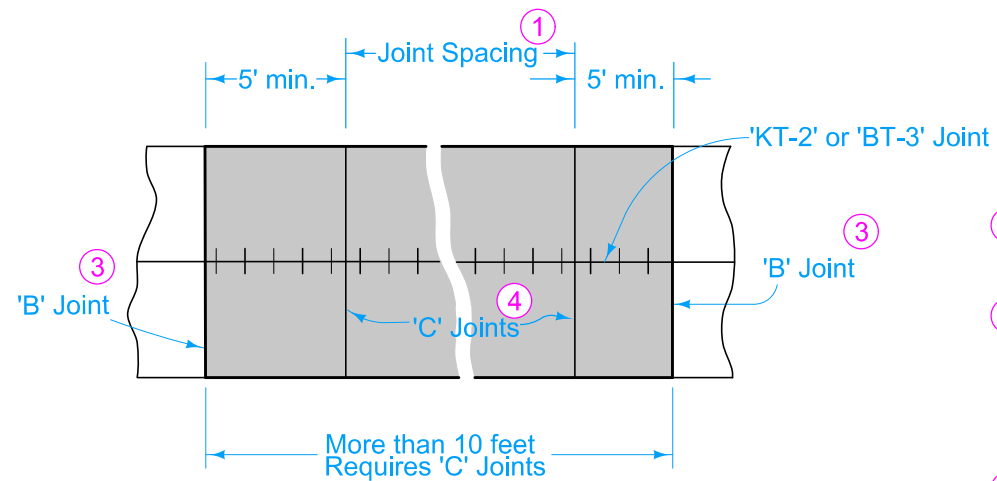

FULL ROADWAY WIDTH PATCH

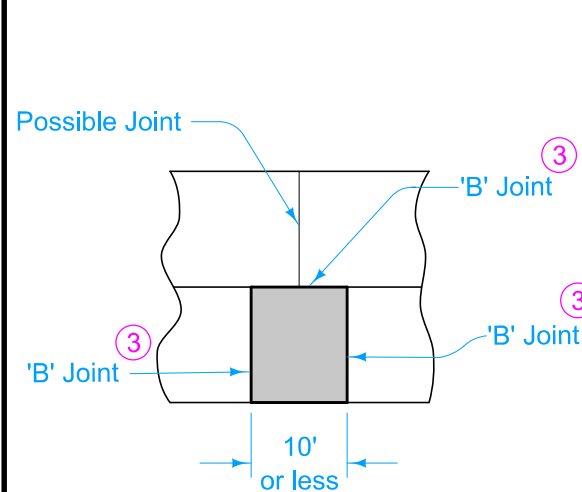

ONE LANE WIDTH PATCH

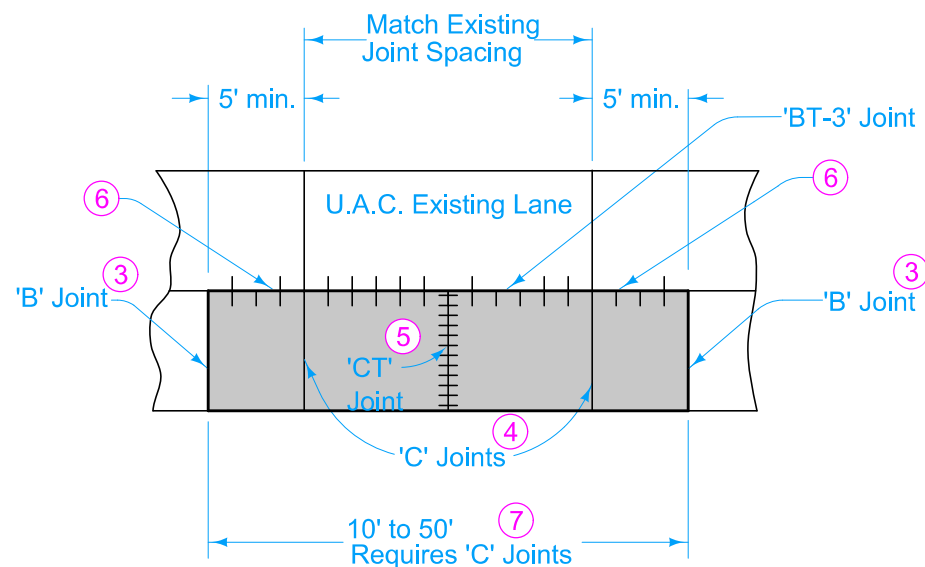

ONE LANE WIDTH PATCH

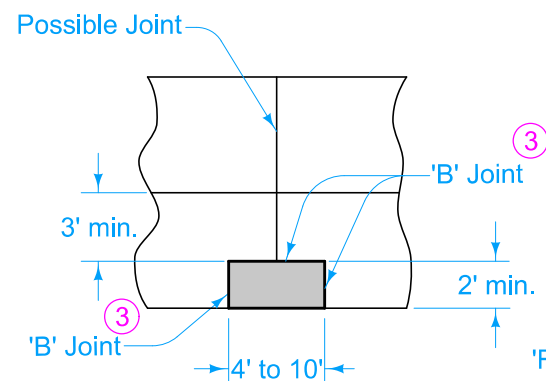

PARTIAL LANE WIDTH PATCH

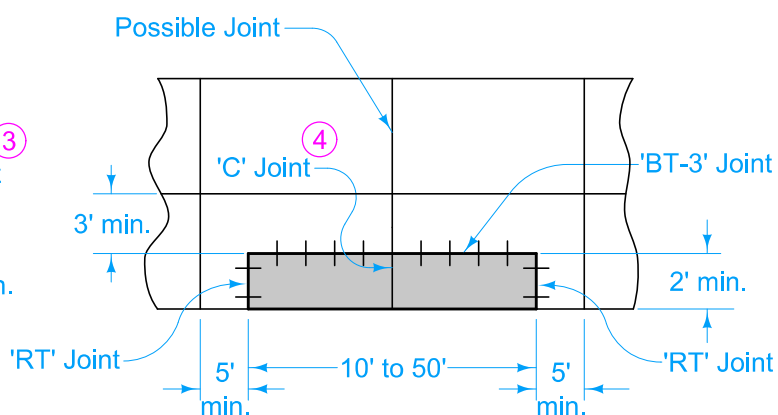

PARTIAL LANE WIDTH PATCH

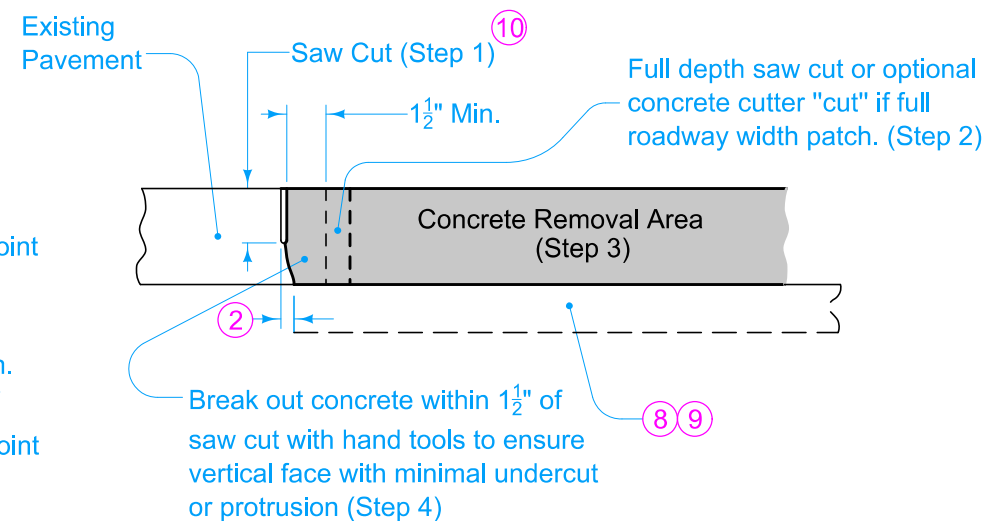

PAVEMENT REMOVAL

- ① Joint spacing 10 feet minimum, 17 feet maximum, 15 feet optimum.
- ② The face of the patch should be near vertical. Protrusions less than 2 inches need not be removed if uniformly tapered from bottom of saw cut to bottom of patch. A step or ledge on this face will not be allowed.
- ③ If resurfacing is part of the contract, do not saw or seal joint after patching. If patch is not to be surfaced, then saw and seal according to PV-101.
- ④ If resurfacing is part of the contract, saw 'C' joints, but do not seal. If the patch is not to be resurfaced, then saw and seal according to PV-101.

See PV-101 for joint and bar placement details.
Construct rectangular patches even when existing pavement joints are skewed.

- ⑤ Establish a new joint at approximate mid patch. This joint does not need to align with any existing joint or crack in adjacent pavement.
- ⑥ 'B' joint if end of patch does not match an existing joint or crack in the adjacent lane.
- ⑦ If one lane patch exceeds 50 feet, both lanes should be considered for patching.
- ⑧ Possible Subbase Patch, see PR-140.
- ⑨ If longitudinal subdrain (shoulder) is not to be placed or if it is not present on side of roadway to be patched, then place drain per PR-140.
- ⑩ Saw cut through overlay so that cut is 1 1/2 inches into original pavement.

Possible Contract Items:

- CT Joint
- Patches, Full-Depth Repair
- Patches by Count (Repair)
- Patches, Full-Depth Finish, by Count
- Patches, Full-Depth Finish, by Area
- Patches, Full-Depth Finish, by Area (50 feet or greater in length)

Possible Tabulation:
102-6C

	REVISION	
	3	04-21-20
STANDARD ROAD PLAN		PR-102
<small>REVISIONS: Removed INTERIM from the standard.</small>		<small>SHEET 1 of 1</small>
<small>APPROVED BY DESIGN METHODS ENGINEER</small>		
FULL DEPTH PCC PATCH WITHOUT DOWELS		