

Place Full Depth Patch with 'EF' Joint after the final lift of asphalt has been placed. Porous Backfill and Subdrain may be placed prior to construction of resurfacing of shoulders.

Place Full Depth Patch according to Full Depth Patch specifications and Standard Road Plan PR-103, except as noted on this sheet.

Place Full Depth Patch and 'EF' Joint full width of the roadway. If roadway has PCC shoulders, extend 'CF' joint across shoulder. Cost of placing 'CF' joint is incidental to 'EF' joint.

See PV-101 for joint and bar placement details.

- ① Break out concrete within 1 1/2" of saw cut with hand tools to ensure near vertical face with minimal undercut or protrusion. No need to remove protrusions smaller than 2 inches if uniformly tapered from bottom of saw cut to bottom of pavement. A step or ledge on this face will not be allowed.
- ② 12 inches Modified Subbase is required under Full Depth Patch with 'EF' Joint. Extend Modified Subbase over longitudinal subdrain, if present.
- ③ Unless noted otherwise in the plans, depth of patch, T, is 12 inches regardless of existing pavement thickness.
- ④ If longitudinal subdrain (shoulder) is not to be placed or if it is not present on side of roadway to be patched, then place Patch Subdrain at low end(s) of patch.

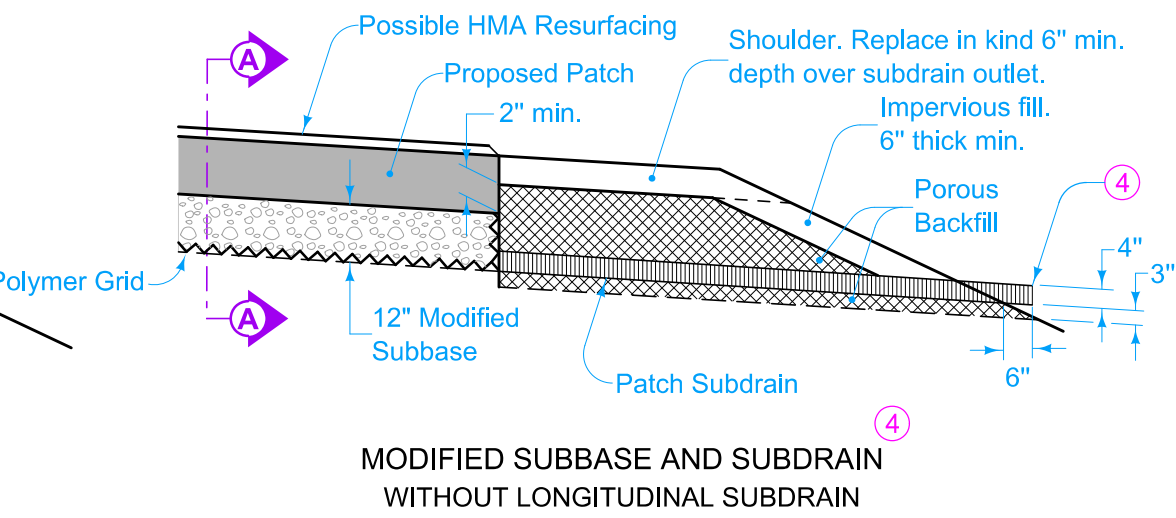
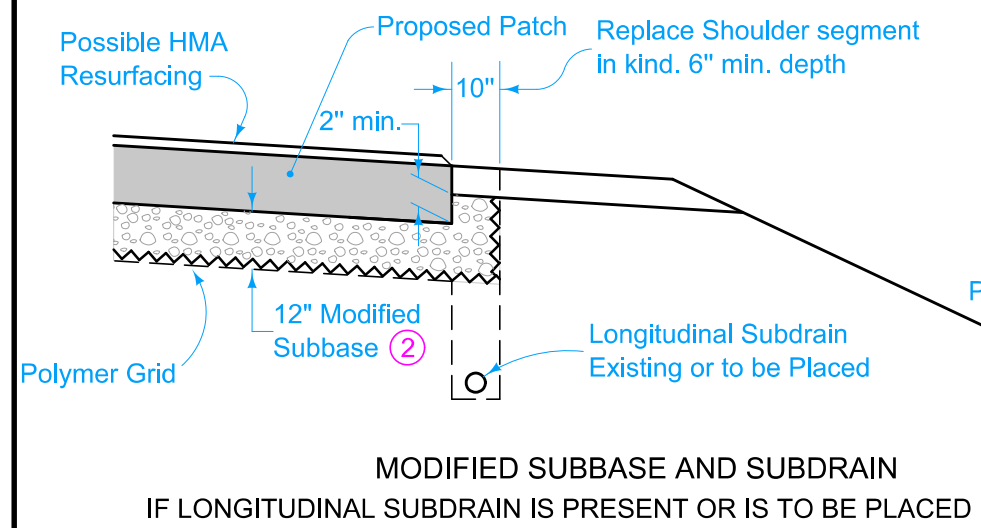

- Possible Contract Items:
- Joint Assembly, EF
 - Patches, Full-Depth Repair
 - Patches by Count (Repair)
 - Patches, Full-Depth Finish, by Count
 - Patches, Full-Depth Finish, by Area
 - Patches, Full-Depth Finish, by Area (50 feet or greater in length)
 - Patch Subdrain
 - Subbase Patch with EF Joint

Possible Tabulation:
102-6C

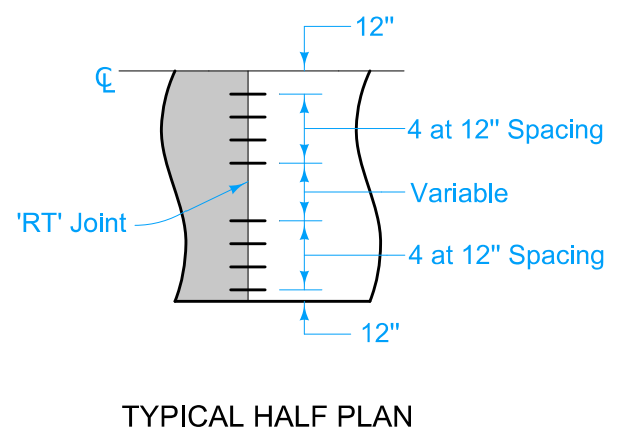
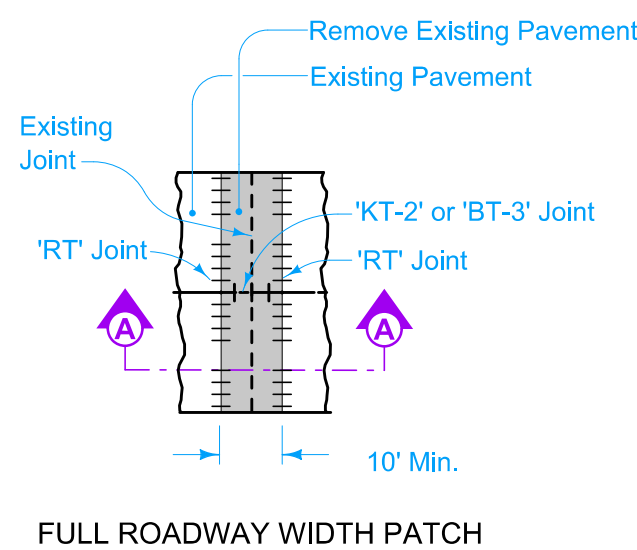
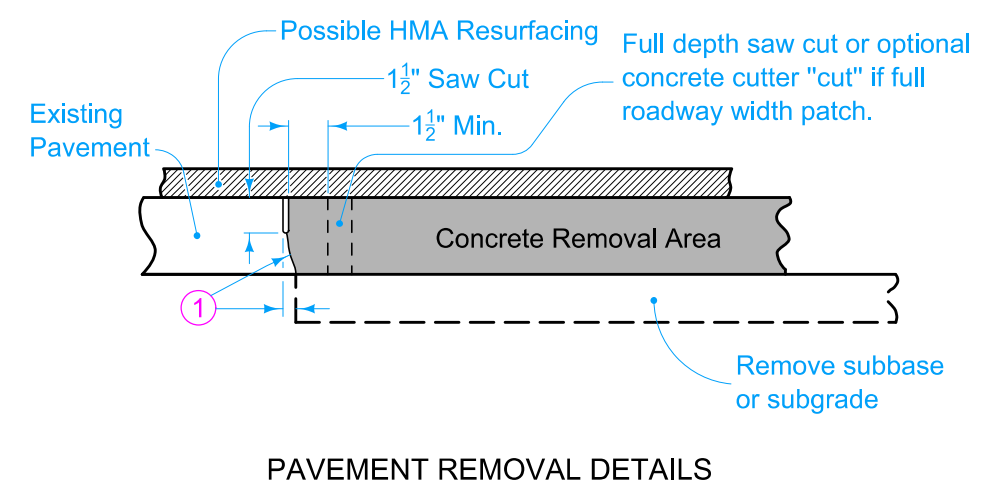

	REVISION	
	1	04-21-15
STANDARD ROAD PLAN		PR-101
		SHEET 1 of 1

REVISIONS: Removed references to rodent guards.

Shawn Miller
APPROVED BY DESIGN METHODS ENGINEER

FULL DEPTH PATCH WITH 'EF' JOINT IN PCC