

TYPE 1

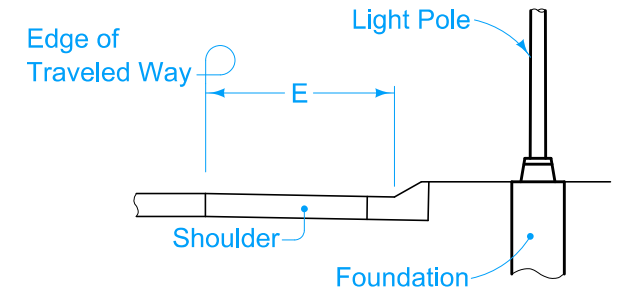

TYPE 2

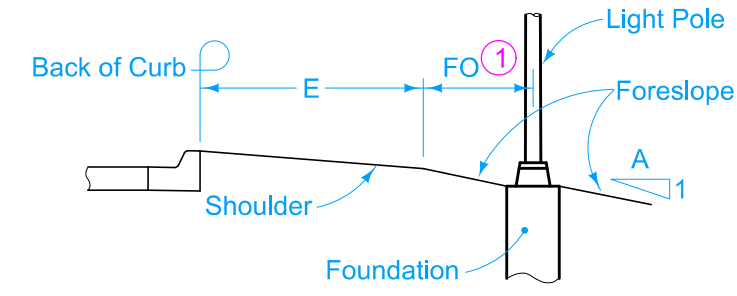

TYPE 3

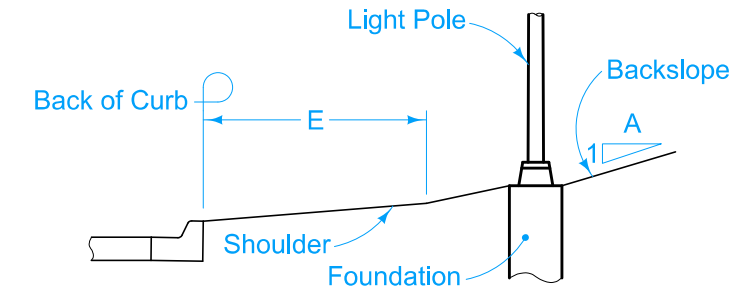

TYPE 4

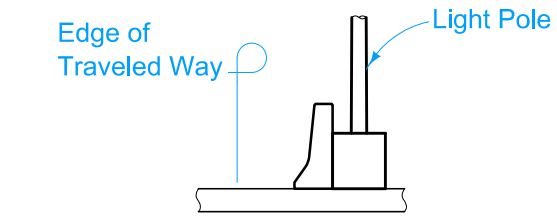

TYPE 5
Concrete Barrier Rail or Bridge Rail

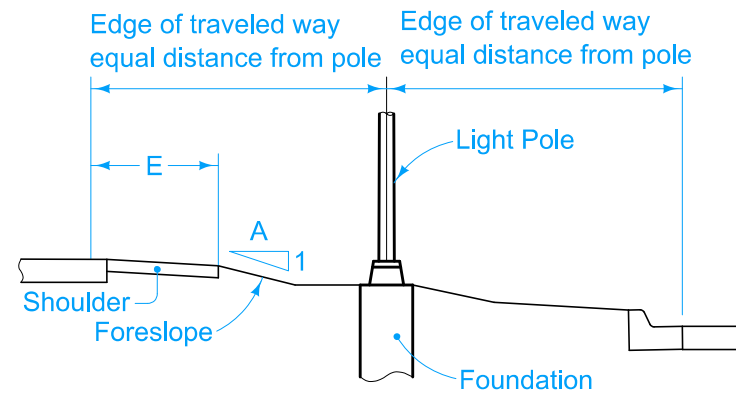

TYPE 6

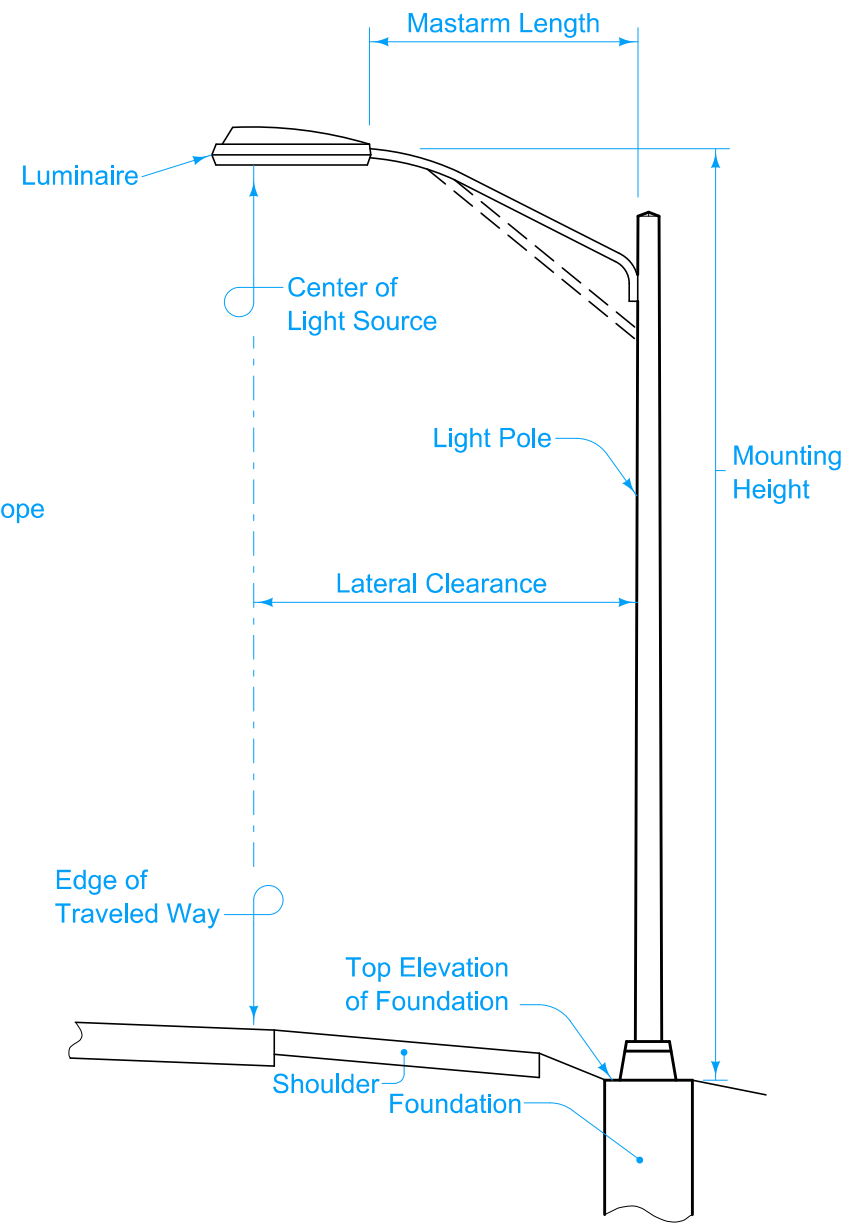

TYPICAL POLE INSTALLATION

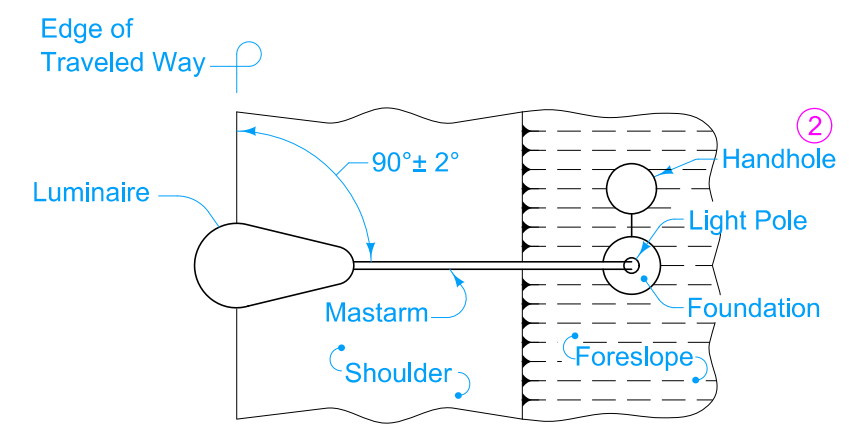

ORIENTATION OF MASTARM

Mounting Height (MH) is the dimension measured vertically from the center of end of mastarm to the top of foundation as shown. Allowable tolerance on MH for final installation is from +3 inches to -3 inches.

Overhang (OH) is the horizontal dimension from the edge of traveled way to the Luminaire center. Unless specifically designated otherwise, design OH is zero, with an allowable tolerance of ±6 inches.

Lateral clearance will be controlled by luminaire dimensions, and by specified overhang and mastarm dimensions. Unless directed otherwise by the Engineer, clearance of adjacent poles having identical mastarm lengths is not to vary by more than ±3 inches.

Orientation: If not specified otherwise, angular orientation of mastarm is $90^\circ \pm 2^\circ$ to the respective centerlines or baselines, or to the respective edges of the pavement along acceleration and deceleration tapers.

Twin-Mastarm Angles: Included angle is to provide required orientation within the nearest 5 degrees increment. Anticipated angle will be shown on the detail plans.

Edge of traveled way is considered to be the edge line.

① Foundation offset (FO) is measured to the centerline of foundation. If the foreslope is steeper than 6:1, FO should be between 2 and 3 feet. If the foreslope is 6:1 or flatter, the FO will vary based on specified mastarm length.

② Slip-base only. May be placed behind pole. Meet the requirements of Article 2523.03, O, of the Standard Specifications.

Possible Contract Item:
Lighting Poles

Possible Tabulation:
108-1

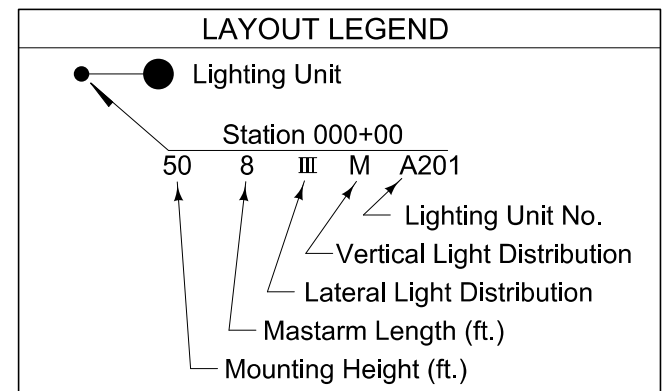

	REVISION	
	New	10-21-14
STANDARD ROAD PLAN		LI-101
REVISIONS: New. Replaces RM-31 and RM-32.		SHEET 1 of 1
 APPROVED BY DESIGN METHODS ENGINEER		

LIGHT POLE LOCATION