

# DESIGNER INFORMATION

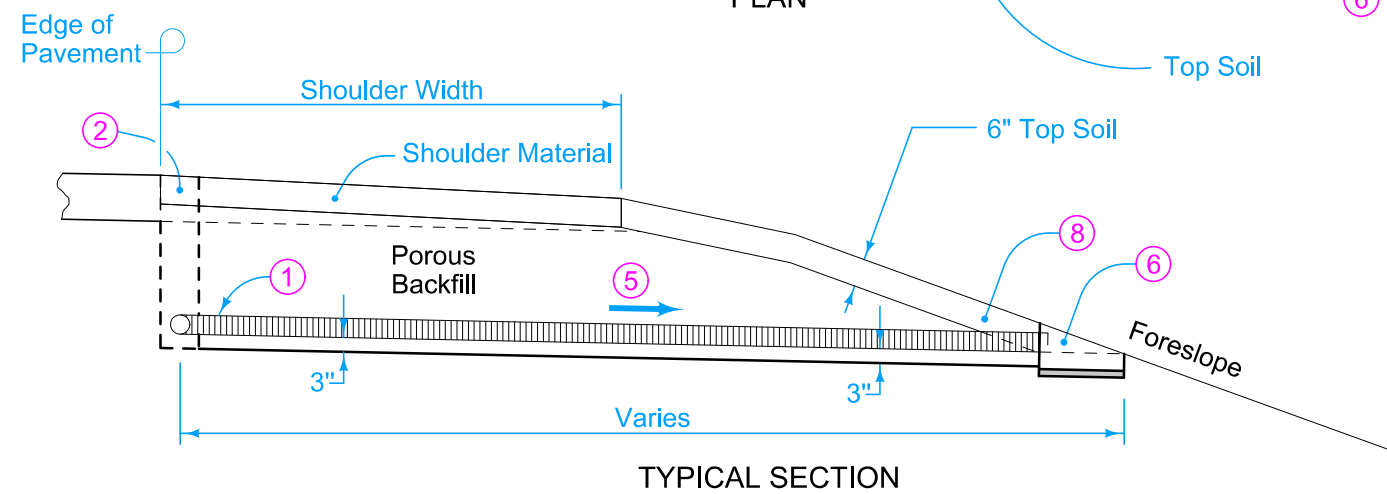

LONGITUDINAL AND TRANSVERSE OUTLETS

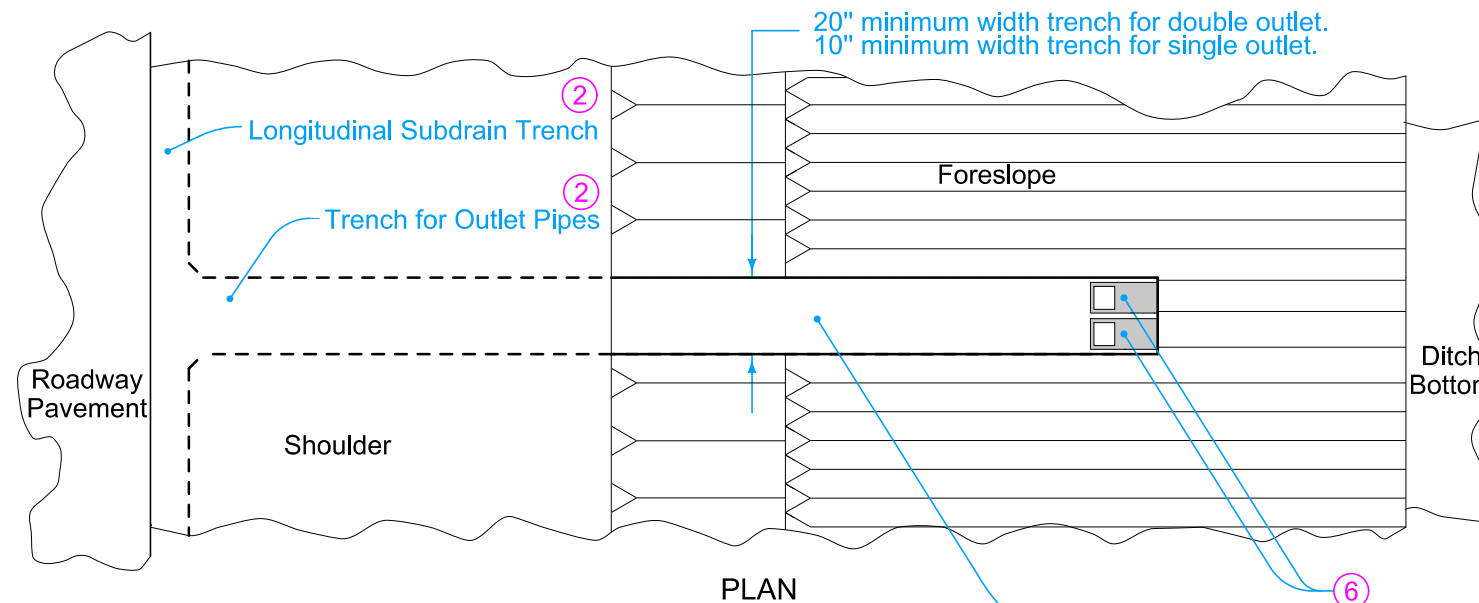
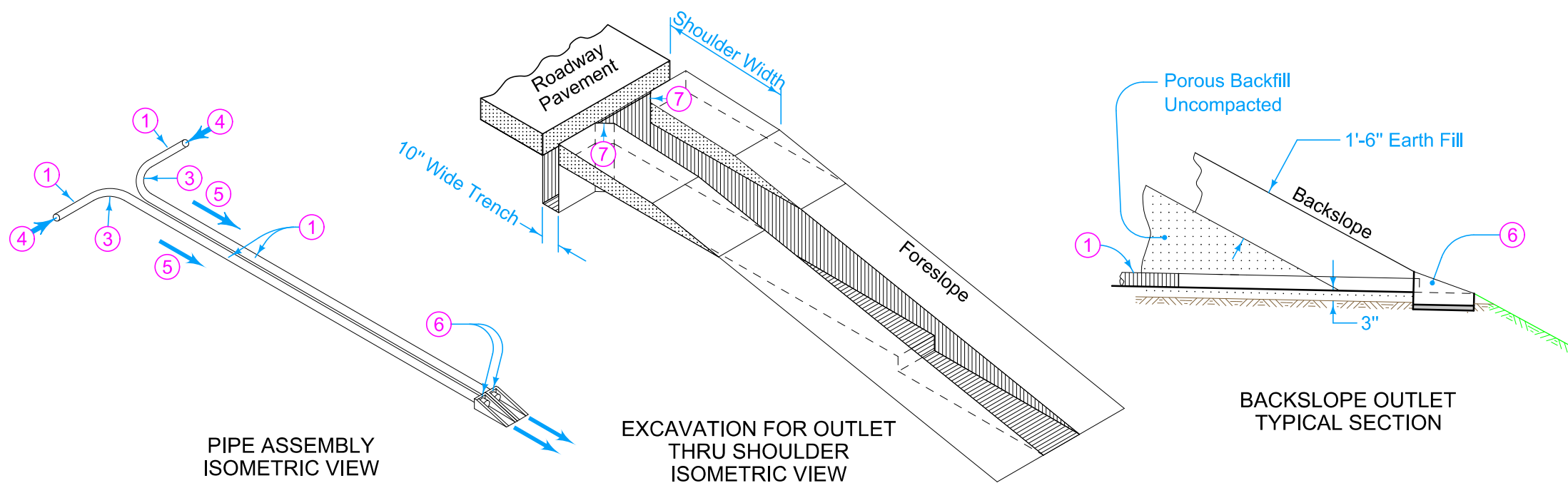

Extend subdrain 3 inches minimum (6 inches maximum) into precast subdrain headwall. Connect using one of the following methods:  
 -Grouted connection using a non-shrink grout complying with Materials I.M. 491.13.  
 -Gasketed connection approved by the Engineer.

Shape adjacent slope to match slope of precast subdrain headwall.

- ① Perforated Subdrain (Polyethylene Corrugated Tubing).
- ② On projects where existing shoulder material is removed, replace the shoulder material according to Article 2502.03, C of the Standard Specifications.
- ③ 'Y' or 'T' connection will not be allowed. Place subdrain on 1 foot minimum radius.
- ④ Direction of flow.
- ⑤ 6 inch minimum drop in elevation between longitudinal subdrain and outlet. 12 inch minimum drop for projects using recycled PCC subbase.
- ⑥ Precast concrete headwall.
- ⑦ Bevel the trench to provide a minimum of 3 inches of porous backfill surrounding all portions of subdrain pipe.
- ⑧ Place Top Soil over outlet and carefully compact to avoid damaging outlet pipe.

Possible Contract Item:  
Subdrain Outlet, DR-306

Possible Tabulation:  
104-5C  
104-9

	REVISION	
	2	10-17-23
<b>STANDARD ROAD PLAN</b>		<b>DR-306</b>
		SHEET 1 of 2

REVISIONS: Change from granular cap to top soil cap.

*Shawn Miller*  
APPROVED BY DESIGN METHODS ENGINEER

## PRECAST CONCRETE HEADWALL FOR SUBDRAIN OUTLETS

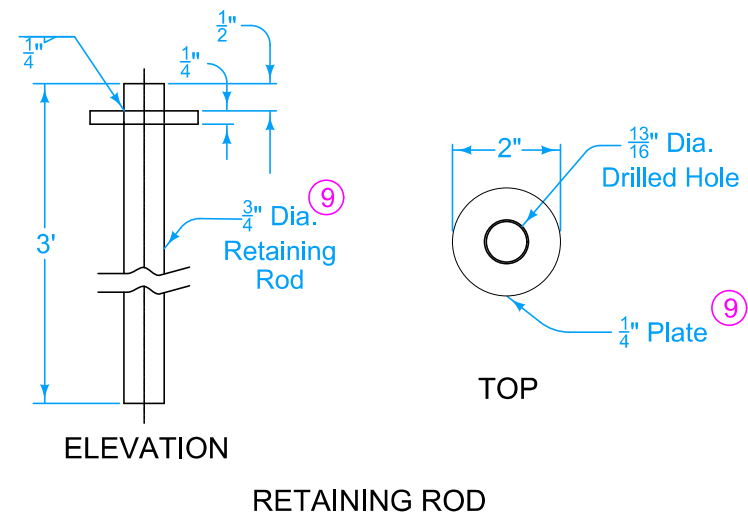
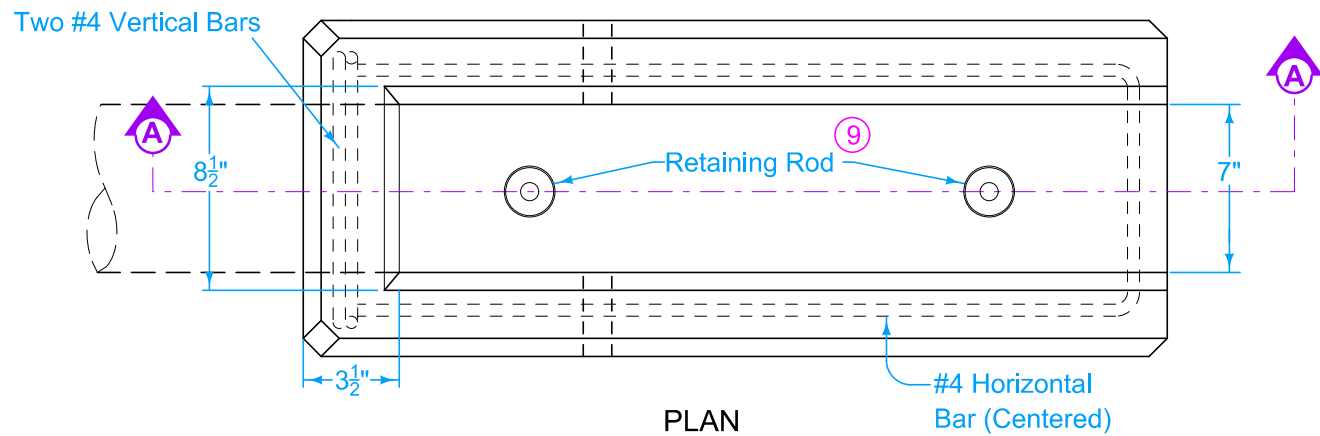

Comply with Section 2419 of the Standard Specifications.

⑨ ASTM A36 Steel galvanized according to ASTM A123 or ASTM F2329 after shop welding is complete.

⑩ After installing retaining rod, fill recess with bituminous material complying with ASTM C990 to prevent moisture infiltration.

⑪ Granular material complying with Section 4133 of the Standard Specifications.

⑫ Maximum diameter 2 inches. Fill hole with soil tight plug after placing headwall and before placing backfill.

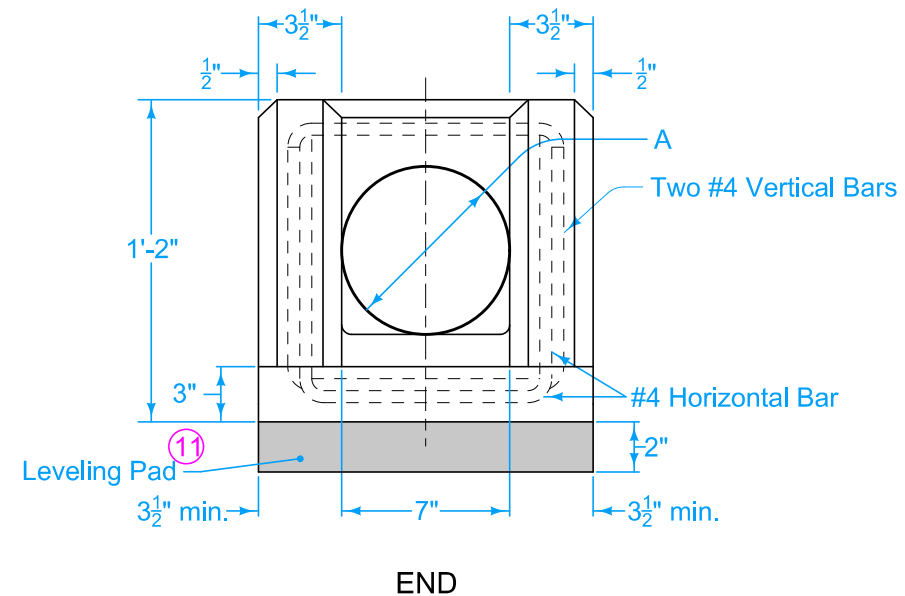
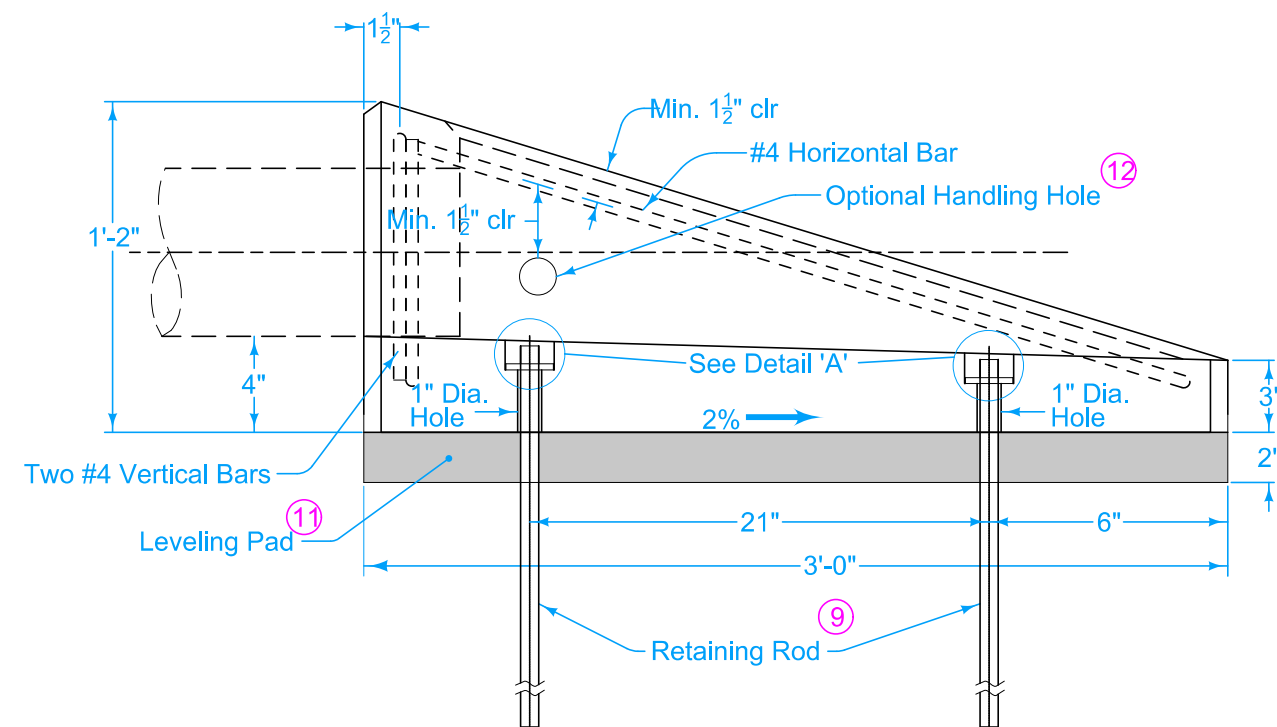

DIMENSION	4" DIA PIPE	6" DIA PIPE
A	5"	7"

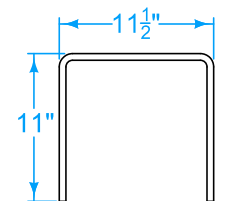
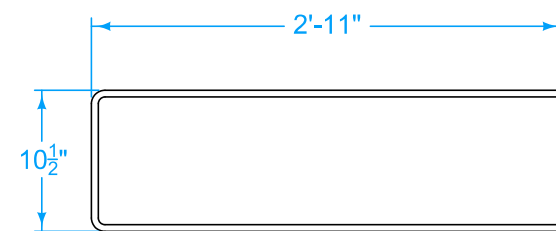

BENT BAR SHAPES

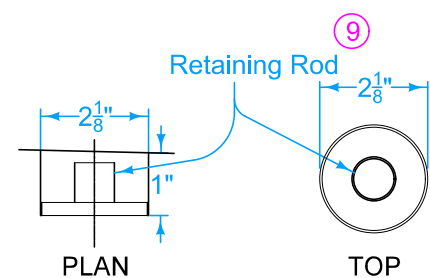

DETAIL 'A'  
(Recess for Retaining Rod)

	REVISION	
	2	10-17-23
<b>STANDARD ROAD PLAN</b>		<b>DR-306</b>
REVISIONS: Change from granular cap to top soil cap.		SHEET 2 of 2
 APPROVED BY DESIGN METHODS ENGINEER		
<b>PRECAST CONCRETE HEADWALL FOR SUBDRAIN OUTLETS</b>		