

Drainage

Drainage

NO.	DATE	TITLE
DR-101	04-18-17	Pipe Culvert (Bedding and Backfill)
DR-102	04-21-15	Pipe Culvert (Cover and Camber)
DR-103	04-21-15	Pipe Culvert (Installation Details)
DR-104	04-19-16	Depth of Cover Tables for Concrete and Corrugated Pipe
DR-111	04-17-18	Box Culvert (Backfill)
DR-121	04-18-23	Connected Pipe Joints
DR-122	10-18-16	Construction of Type "C" Concrete Adaptors for Pipe Culvert Connections
DR-141	04-18-17	Pipe Bends and Half Pipe
DR-142	10-19-21	Culvert Pipe Tee Sections
DR-201	10-17-23	Concrete Aprons
DR-202	10-17-23	Low Clearance Concrete Pipe Aprons
DR-203	04-21-20	Metal Pipe Aprons and Beveled Ends
DR-204	04-21-20	Metal Arch Aprons (for Corrugated Metal Pipe)
DR-205	10-17-23	Concrete Apron with End Wall
DR-206	10-17-23	Low Clearance Concrete Pipe Apron With End Wall
DR-211	04-21-20	Metal Safety Slope Apron 6:1 Slope
DR-212	04-21-20	Beveled Pipe and Guard
DR-213	10-18-22	Pipe Apron Guard
DR-301	04-19-22	Subdrains for Fill or Foundation Drainage (Standard)
DR-302	04-18-23	Subdrains Standard (Farm Tile Replacement)
DR-303	10-17-17	Subdrains (Longitudinal)
DR-305	04-19-22	Subdrain Outlets (Standard Subdrain, Pressure Release and Special)
DR-306	10-17-23	Precast Concrete Headwall for Subdrain Outlets
DR-401	04-16-24	Scour Protection for Bridge End Drain
DR-402	04-16-24	Rock Flume for Bridge End Drain
DR-501	04-17-18	Corrugated Metal Type "A" Diaphragm
DR-502	10-18-16	Slotted Drain for Median Crossovers
DR-503	04-21-20	Safety Grates for Box Culverts

Drainage

NO.	DATE	TITLE
DR-504	04-21-20	Diagonal Placed Drain for Median Crossovers
DR-601	04-18-17	Reinforced Concrete Pipe Culvert
DR-602	04-18-17	Reinforced Concrete Pipe Culvert with Tees
DR-611	04-18-17	Reinforced Concrete Pipe Culvert Letdown Structure
DR-612	04-18-17	Apron Tee Inlet
DR-613	04-17-18	Concrete Pipewith "D" Section
DR-621	04-18-17	Pipe Extension
DR-622	10-17-17	Pipe Extension Horizontal Bend One or Both Ends
DR-625	04-18-17	Pipe Extension Letdown Structure with Metal Apron
DR-626	10-15-19	Pipe Extension - Adding Lanes
DR-627	10-15-19	Pipe Extension Horizontal Bend - Adding Lanes
DR-628	10-15-19	Pipe Extension Both Ends Horizontal Bend (Optional) - Adding Lanes
DR-629	04-18-17	Pipe Extension Letdown Structure Horizontal Bend (Optional) - Adding Lanes
DR-631	04-18-17	Corrugated Pipe Culvert Letdown Structure with Single Elbow
DR-632	04-18-17	Corrugated Pipe Culvert Letdown Structure with Double Elbow
DR-641	04-21-20	Concrete/Corrugated Pipe Culvert Letdown Structure with Metal Apron
DR-642	04-18-17	Apron Pipe Tee Inlet
DR-651	04-18-17	Unclassified Pipe Culvert
DR-652	04-18-17	Unclassified Letdown Structure Single Elbow
DR-653	04-18-17	Unclassified Roadway Letdown Pipe with Metal Apron

Refer to DR-104 for minimum and maximum allowable cover H for the particular kind of pipe culvert.

- ① The backfill adjacent to and above the pipe culvert may be placed in conjunction with normal embankment construction. Thoroughly tamp the embankment within the limits shown.
- ② Take extra care to ensure complete and satisfactory tamping of backfill material in the area immediately adjacent to the lower portion of pipe.
- ③ Carefully shape excavation below groundline either using a template conforming to actual dimension and shape of the pipe or using other means. If using other means, check with a template conforming to the actual dimension and shape of the pipe.
- ④ For culverts backfilled by flooding, place a cohesive soil plug at the inlet, outlet, and, when necessary, sides, prior to flooding.
- ⑤ 4-inch Porous Backfill bedding. 2-inch Floodable Backfill bedding may be used under unsealed rigid pipe.
- ⑥ Extend Porous Backfill through the outlet end soil plug when used for bedding.
- ⑦ Quantity calculations are based upon a 1:1 slope and minimum trench dimension. Actual slope of trench may vary based upon Contractor's operations.
- ⑧ Ground Line at time of pipe installation. When existing ground exceeds 5 feet depth over pipe, backfill and compaction by flooding is not required more than 5 feet above the pipe.
- ⑨ Where a corrugated metal pipe culvert requiring elongation is to be installed (to counteract deformation caused by backfill), complete elongation using a means approved by the Engineer. Elongation may be developed either as part of shop fabrication or field installation. Install with elongated axis vertical.

Possible Contract Items:
Flowable Mortar
Flooded Backfill
Excavation, Class 20

Possible Tabulations:
104-3
104-4

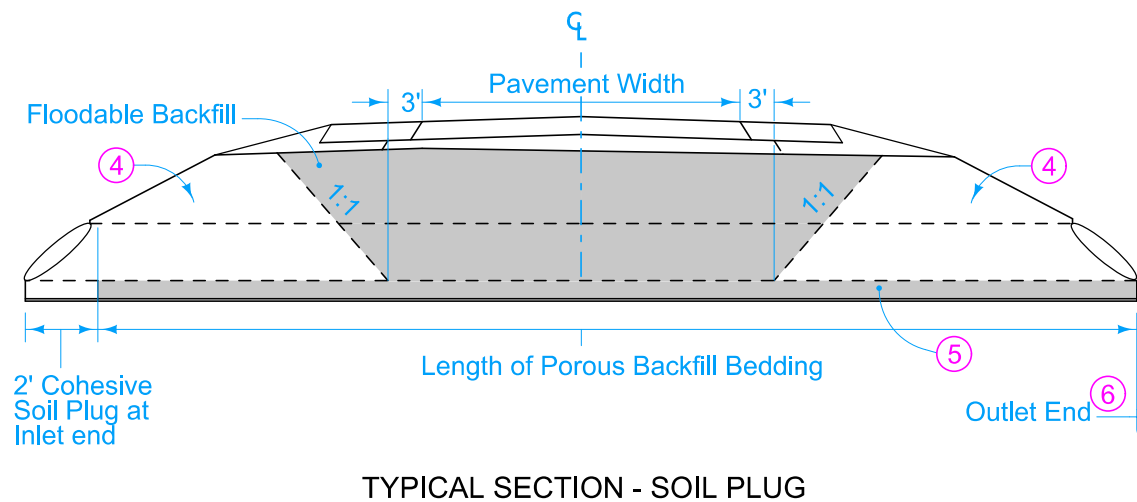
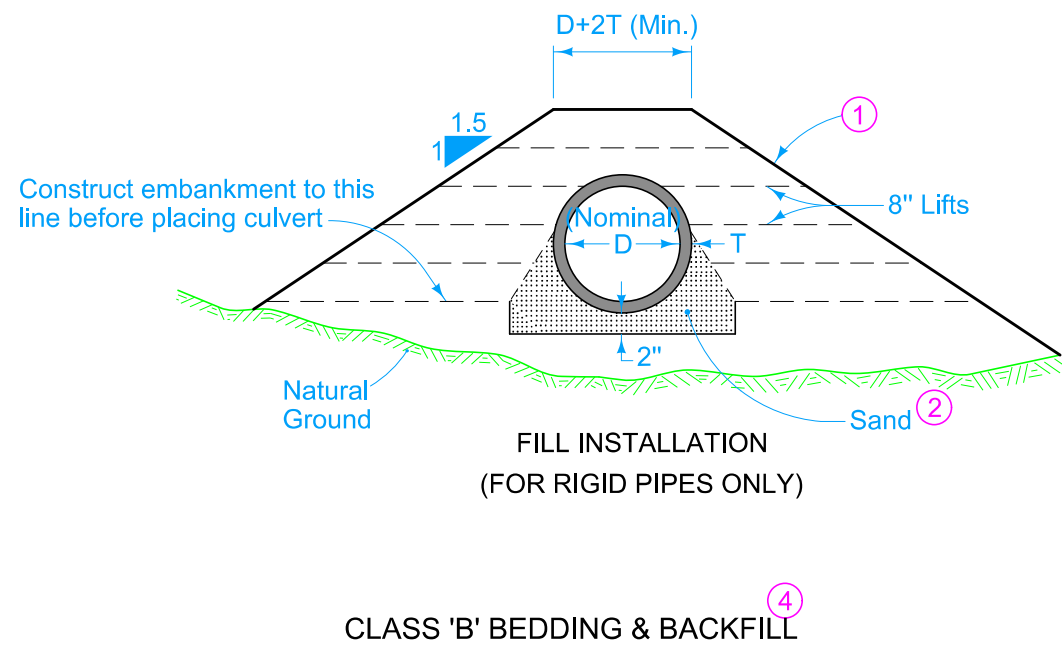
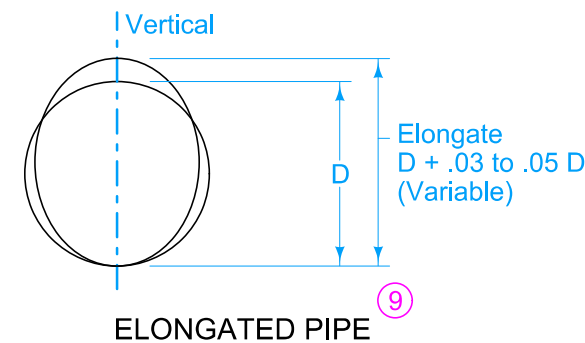
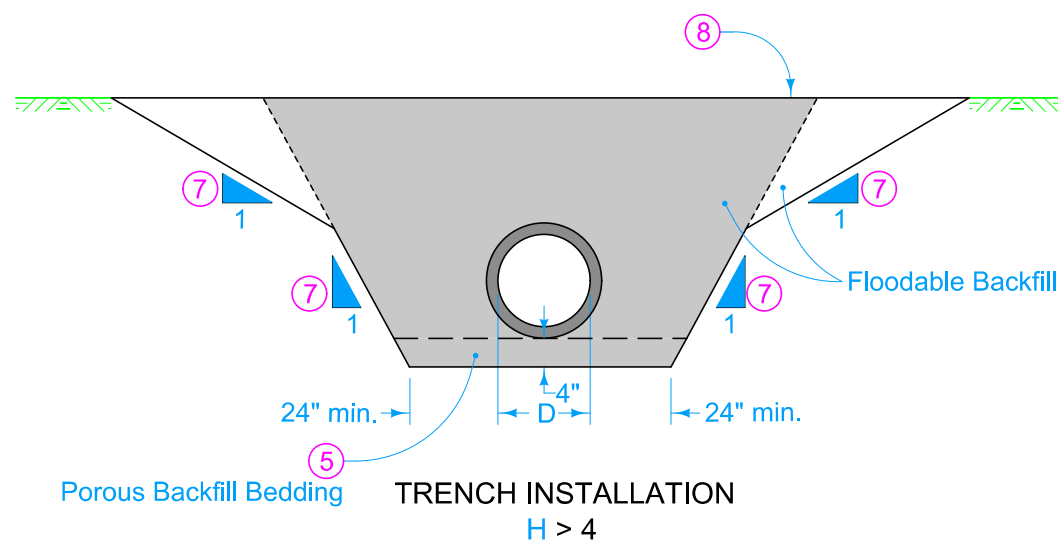
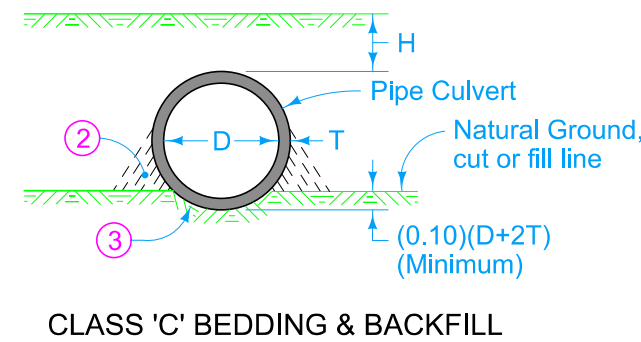
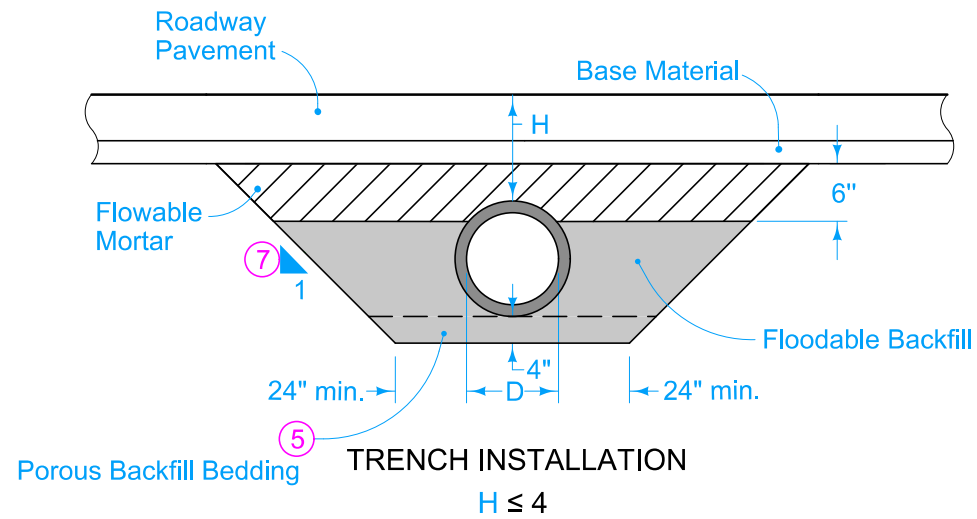

Denotes pay limits for flooded backfill

	REVISION	
	2	04-18-17
STANDARD ROAD PLAN		DR-101
		SHEET 1 of 1

REVISIONS: Changed "Porous Backfill" to "Porous Backfill Bedding" for clarity. Modified trench installation detail for H>4' to clarify pay limits.

APPROVED BY DESIGN METHODS ENGINEER

PIPE CULVERT
(BEDDING AND BACKFILL)

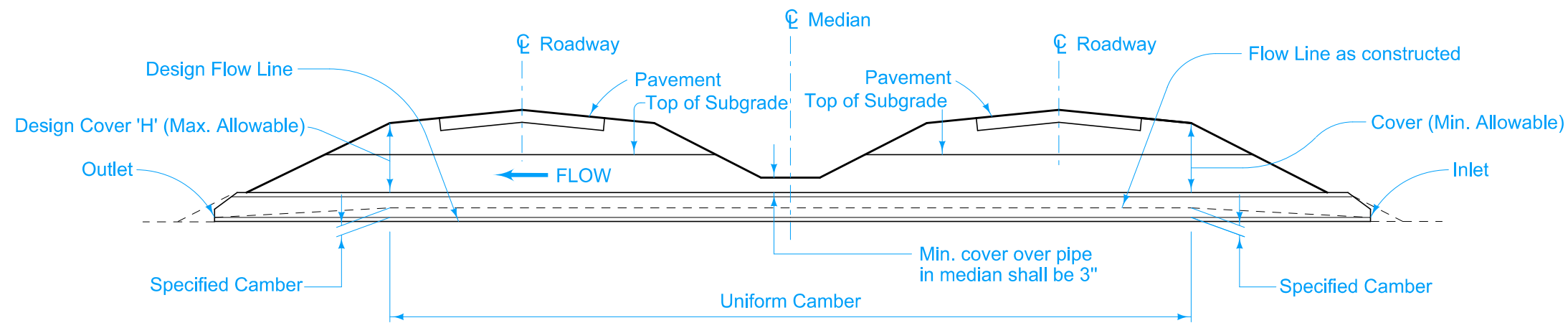

TYPICAL INSTALLATION DUAL ROADWAY

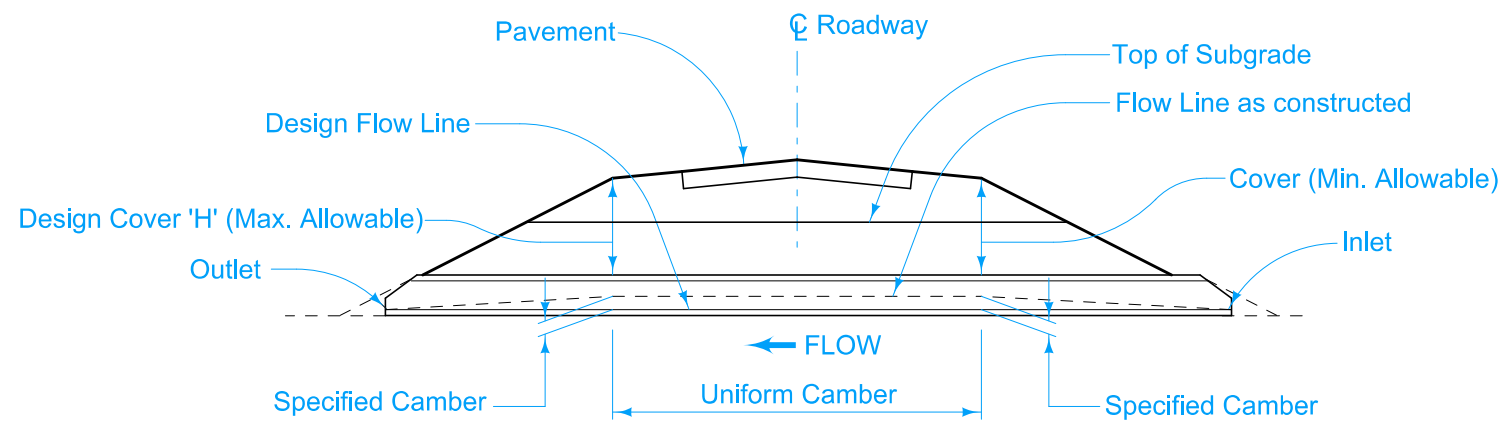

TYPICAL INSTALLATION SINGLE ROADWAY

Refer to DR-121 for pipe joint connection and wrapping.
 Refer to DR-101 for culvert bedding and backfill.
 COVER
 Refer to DR-104 for minimum and maximum allowable cover for the particular kind of culvert.

CAMBER
 Camber is the dimension line between inlet and outlet elevation. Some settlement of the structure is usually anticipated, resulting in the design flow line between inlet and outlet. Camber is developed uniformly from inlet and outlet to a point beneath the outside shoulder lines of the roadway and is uniform between those points, as indicated. The Normal Camber indicated in the "Allowable Camber Tables" should be used unless specific camber values are indicated elsewhere in the plans.

① Camber for concrete pipe is created by placing pipe sections tight at the bottom of the joint with variable opening at top of joint. Camber for corrugated metal pipe to be done as directed by the Engineer.

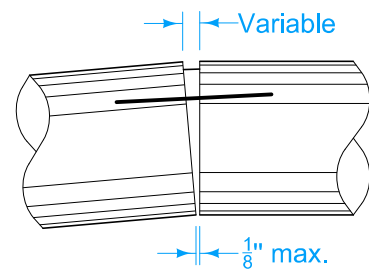

TYPICAL JOINT IN CAMBERED PIPE

Design Cover 'H' (feet)	Normal Camber (feet)
5	0.08
10	0.17
15	0.25
20	0.33
25	0.42
30	0.50
35	0.58

Pipe Size 'D'	Maximum Camber (feet)
24"	1.1
30"	1.2
36"	1.3
42"	1.4
48"	1.5
60"	1.6
84"	1.7

ALLOWABLE CAMBER TABLES

	REVISION	
	New	04-21-15
STANDARD ROAD PLAN		DR-102
REVISIONS: New. Replaces RF-30B.		SHEET 1 of 1
 APPROVED BY DESIGN METHODS ENGINEER		
PIPE CULVERT (COVER AND CAMBER)		

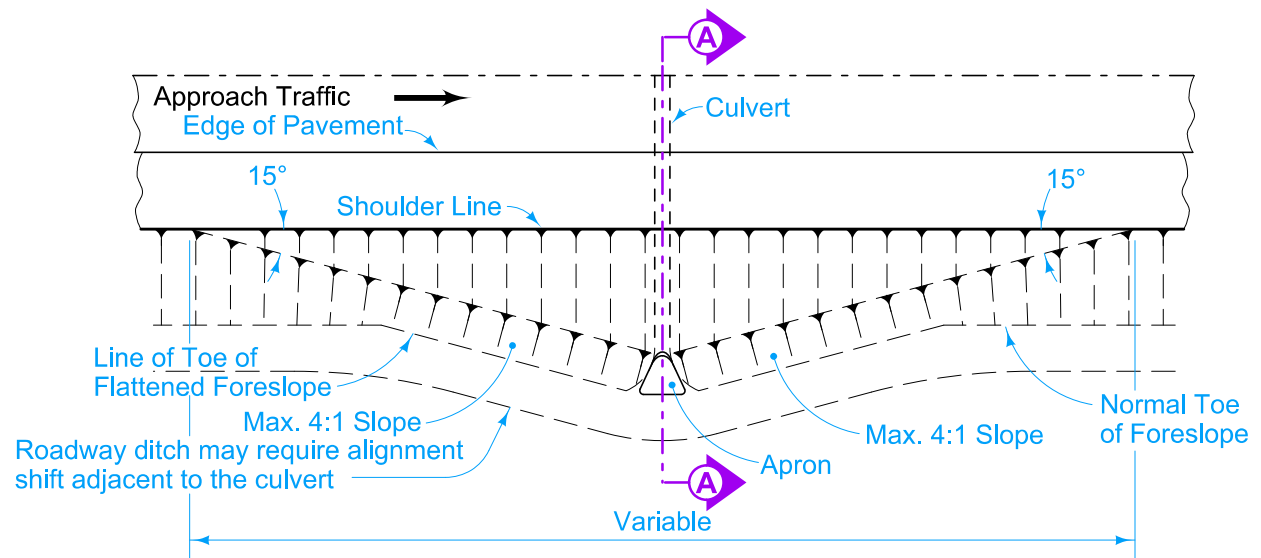

TYPICAL INSTALLATION PLAN
WHERE SPECIAL BERM IS REQUIRED

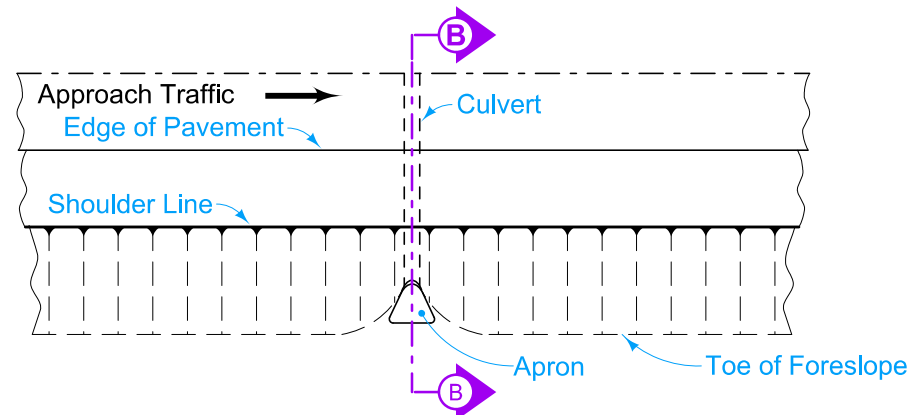

TYPICAL INSTALLATION PLAN
WHERE CULVERT MATCHES NORMAL FORESLOPE

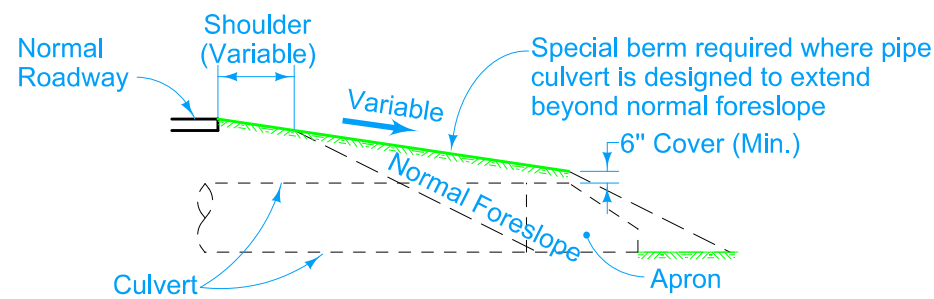

SECTION A-A

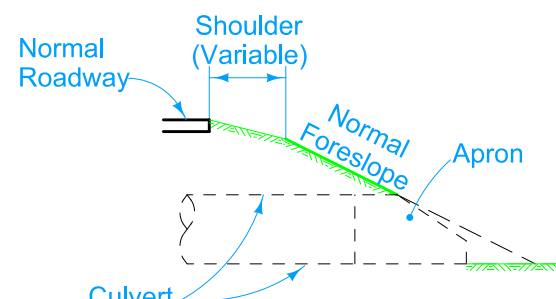

SECTION B-B

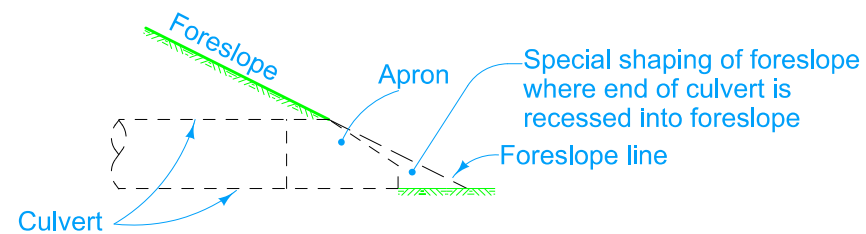

DETAIL OF SHAPING EARTH FORESLOPE
AT CULVERT END

	REVISION	
	New	04-21-15
STANDARD ROAD PLAN		DR-103
REVISIONS: New. Replaces RF-30C.		SHEET 1 of 1

APPROVED BY DESIGN METHODS ENGINEER

**PIPE CULVERT
(INSTALLATION DETAILS)**

DESIGN CRITERIA FOR CONCRETE PIPE

The height of cover tables have been prepared from data in the "Concrete Pipe Design Manual" published by the American Concrete Pipe Association using the values listed below.

FOR EMBANKMENT CONDITIONS

Fill Material Density = $w = 120$ lbs. per cu. ft.
 Settlement Ratio = $rsd = +0.5$
 * = $ku = 0.13$
 Projection Ratio = $p = 0.9$ (Class "C" bedding)
 = $p = 0.7$ (Class "B" bedding)
 Factor of Safety = $F.S. = 1.33$ on Ultimate Strength

* Using a ratio of lateral to vertical earth pressure (k) of 0.37 (saturated yellow clay) and a coefficient of internal friction (u) of 0.34.

The values shown for concrete pipe were calculated for concrete pipe placed under embankment conditions. These values do not apply to design and installation of sanitary sewer except where sanitary sewer would be placed under embankment conditions.

CONCRETE CULVERT PIPE CLASS "B" BEDDING				
DIAMETER OF PIPE 'D' Inches	(H) MAXIMUM ALLOWABLE COVER IN FEET			
	1500D (Class II)	2000D (Class III)	3000D (Class IV)	3750D (Class V)
18	11	13	20	25
24	12	14	21	26
36	13	16	23	28
48	14	16	24	29
60	14	17	24	29
72	14	17	24	30
84	15	17	25	30
96	15	18	25	31
108	15	18	26	32

CONCRETE CULVERT PIPE CLASS "C" BEDDING				
DIAMETER OF PIPE 'D' Inches	(H) MAXIMUM ALLOWABLE COVER IN FEET			
	1500D (Class II)	2000D (Class III)	3000D (Class IV)	3750D (Class V)
18	9	12	18	22
24	10	13	19	23
36	11	14	20	24
48	11	15	21	25
60	12	15	21	26
72	12	16	22	26
84	13	16	22	27
96	13	16	23	27
108	13	17	23	28

When unclassified pipe is specified, furnish and install a class of pipe meeting the requirements on the chart.

For Steel Round Pipe, the Contractor may choose the type of corrugated pipe and installation to furnish as long as the selection conforms to the limits indicated for the type specified.

When furnishing Steel Arch Pipe, furnish pipe with corrugations as specified in plans.

Minimum allowable cover for concrete and metal pipe is 2 feet for roadway culverts and 1 foot for entrance culverts.

Maximum cover for all sizes and installations of concrete arch pipe is 12 feet.

For all sizes and installations of polyethylene pipe:
 minimum cover = 2 feet
 maximum cover = 24 feet for 12 to 24 inch pipes
 20 feet for 30 to 48 inch pipes



Where a pipe size not listed in the table is required, the 'H' indicated for the next smaller size will apply.

Special installations may be designed to exceed indicated maximum allowable cover by specific modification of one or more of the following conditions:

1. Bedding Class
2. Pipe Strength (including special design pipe)
3. Type of backfill or cover material
4. Compaction requirements for backfill or cover material
5. Controlled trench width

Where site conditions favor such modifications, significant economy may result from special design installations and these should be considered. Special designs will specify particular modification of construction requirements or design criteria as applicable. Necessary modifications of normal requirements will not ordinarily be paid for separately but will be included in the price bid for culvert pipe.

CONCRETE CULVERT PIPE

 STANDARD ROAD PLAN	REVISION	
	1	04-19-16
DR-104		SHEET 1 of 3
REVISIONS: Added general note regarding maximum cover on concrete arch pipes.		
 APPROVED BY DESIGN METHODS ENGINEER		
DEPTH OF COVER TABLES FOR CONCRETE AND CORRUGATED PIPE		

STEEL ROUND PIPE 2 2/3" x 1/2" CORRUGATIONS											
DIAMETER OF PIPE 'D' Inches	MINIMUM COVER ABOVE PIPE Inches	(H) MAXIMUM ALLOWABLE COVER IN FEET									
		16 GAGE (0.064")		14 GAGE (0.079")		12 GAGE (0.109")		10 GAGE (0.138")		8 GAGE (0.168")	
		*	**	*	**	*	**	*	**	*	**
12	12	70	-	76	-	-	-	-	-	-	-
15	12	56	-	61	-	-	-	-	-	-	-
18	12	40	-	48	-	64	-	-	-	-	-
24	12	23	-	26	-	33	-	-	-	-	-
30	12	-	-	18	30	22	43	25	51	-	-
36	12	-	-	15	25	17	33	19	38	-	-
42	12	-	-	-	-	14	28	16	31	17	34
48	12	-	-	-	-	13	25	14	27	15	29
54	18	-	-	-	-	12	24	13	25	13	26
60	18	-	-	-	-	-	-	12	23	12	25
66	18	-	-	-	-	-	-	11	22	12	23
72	18	-	-	-	-	-	-	11	17	11	21
78	24	-	-	-	-	-	-	-	-	11	17
84	24	-	-	-	-	-	-	-	-	11	13

* Round ** Elongated



STEEL ROUND PIPE 3" X 1" and 5" X 1" CORRUGATIONS											
DIAMETER OF PIPE 'D' Inches	MINIMUM COVER ABOVE PIPE Inches	(H) MAXIMUM ALLOWABLE COVER IN FEET									
		16 GAGE (0.064")		14 GAGE (0.079")		12 GAGE (0.109")		10 GAGE (0.138")		8 GAGE (0.168")	
		*	**	*	**	*	**	*	**	*	**
36	12	27	40	31	50	40	74	-	-	-	-
42	12	21	34	23	42	29	58	-	-	-	-
48	12	17	30	19	37	23	46	-	-	-	-
54	12	15	27	16	32	19	38	-	-	-	-
60	12	13	24	15	29	16	33	-	-	-	-
66	12	13	22	13	27	15	30	-	-	-	-
72	12	12	20	12	25	14	27	-	-	-	-
78	12	12	18	12	23	13	26	-	-	-	-
84	12	-	-	12	21	12	24	13	26	-	-
90	12	-	-	-	-	12	24	12	35	13	26
96	12	-	-	-	-	11	23	12	24	12	25
102	24	-	-	-	-	-	-	12	23	12	24
108	24	-	-	-	-	-	-	-	-	12	23
114	24	-	-	-	-	-	-	-	-	11	23
120	24	-	-	-	-	-	-	-	-	11	20

* Round ** Elongated

STRUCTURAL STEEL ROUND PIPE 6" X 2" CORRUGATIONS															
DIAMETER OF PIPE 'D' Inches	MINIMUM COVER ABOVE PIPE Inches	(H) MAXIMUM ALLOWABLE COVER IN FEET													
		12 GAGE (0.109")		10 GAGE (0.138")		8 GAGE (0.168")		7 GAGE (0.187")		5 GAGE (0.218")		3 GAGE (0.250")		1 GAGE (0.281")	
		*	**	*	**	*	**	*	**	*	**	*	**	*	**
60	12	35	35	43	52	51	67	-	-	-	-	-	-	-	-
66	12	29	32	35	45	41	61	-	-	-	-	-	-	-	-
72	12	25	29	29	43	34	56	-	-	-	-	-	-	-	-
78	12	22	27	25	40	29	52	31	60	-	-	-	-	-	-
84	12	19	25	22	37	25	48	27	53	-	-	-	-	-	-
90	12	18	23	20	34	22	44	23	47	-	-	-	-	-	-
96	12	16	22	18	32	20	40	21	42	-	-	-	-	-	-
102	24	15	21	17	30	18	36	19	38	-	-	-	-	-	-
108	24	14	19	16	29	17	34	18	36	-	-	-	-	-	-
114	24	14	18	15	27	16	32	17	33	18	36	-	-	-	-
120	24	13	18	14	26	15	30	16	31	17	33	-	-	-	-
126	24	13	-	13	25	14	29	15	30	16	31	-	-	-	-
132	24	12	-	13	24	14	27	14	28	15	30	-	-	-	-
138	24	12	-	13	23	13	26	14	27	14	29	-	-	-	-
144	24	12	-	12	22	13	26	13	26	14	27	-	-	-	-
150	24	12	-	12	21	12	25	13	26	13	27	14	28	-	-
156	24	11	-	12	20	12	24	12	25	13	26	13	27	-	-
162	24	11	-	12	19	12	24	12	24	13	25	13	26	13	27
168	24	11	-	11	19	12	23	12	24	12	25	13	25	13	26
174	24	11	-	11	18	12	23	12	23	12	24	12	25	13	25
180	24	11	-	11	17	11	23	11	23	12	24	12	24	12	25

* Round ** Elongated

STRUCTURAL STEEL ROUND PIPE

	REVISION	
	1	04-19-16
STANDARD ROAD PLAN		DR-104
SHEET 2 of 3		
REVISIONS: Added general note regarding maximum cover on concrete arch pipes.		
 APPROVED BY DESIGN METHODS ENGINEER		
DEPTH OF COVER TABLES FOR CONCRETE AND CORRUGATED PIPE		



STEEL ARCH PIPE 2 2/3" X 1/2" CORRUGATIONS								
SPAN Inches	RISE Inches	R _c ^① Inches	MINIMUM COVER ABOVE PIPE Inches	(H) MAXIMUM ALLOWABLE COVER IN FEET				
				16 GA. (0.064")	14 GA. (0.079")	12 GA. (0.109")	10 GA. (0.138")	8 GA. (0.168")
17	13	3.5	18	6	6	-	-	-
21	15	4.125	18	6	6	-	-	-
24	18	4.875	18	5	5	-	-	-
28	20	5.5	18	5	5	-	-	-
35	24	6.875	18	5	5	-	-	-
42	29	8.25	18	4	4	-	-	-
49	33	9.625	18	-	-	4	4	4
57	38	11.0	18	-	-	4	4	4
64	43	12.375	18	-	-	4	4	4
71	47	13.75	18	-	-	-	4	4
77	52	15.125	18	-	-	-	-	4
83	57	16.5	18	-	-	-	-	4

STEEL ARCH PIPE 3" X 1" and 5" X 1" CORRUGATIONS								
SPAN Inches	RISE Inches	R _c ^① Inches	MINIMUM COVER ABOVE PIPE Inches	(H) MAX. ALLOWABLE COVER IN FT.				
				16 GA. (0.064")	14 GA. (0.079")	12 GA. (0.109")	10 GA. (0.138")	
60	46	18.75	18	6	6	-	-	
66	51	20.75	18	6	6	-	-	
73	55	22.875	18	8	8	-	-	
81	59	20.875	18	-	7	7	-	
87	63	22.625	18	-	7	7	-	
95	67	24.375	18	-	6	6	-	
103	71	26.125	24	-	-	6	-	
112	75	27.75	24	-	-	5	-	
117	79	29.5	24	-	-	5	-	
128	83	31.25	24	-	-	-	5	

① Corner Radius, R_c, changes from 18 inches to 31 inches for the 6 in. x 2 in. corrugation.

STRUCTURAL STEEL ARCH PIPE 6" X 2" CORRUGATIONS							
SPAN Inches	RISE Inches	R _c ^① Inches	MINIMUM COVER ABOVE PIPE Inches	(H) MAXIMUM ALLOWABLE COVER IN FEET			
				12 GA. (0.109")	10 GA. (0.138")	8 GA. (0.168")	7 GA. (0.187")
73	55	18	18	8	-	-	-
84	61	18	18	7	-	-	-
95	67	18	18	6	-	-	-
106	73	18	24	6	-	-	-
117	79	18	24	5	-	-	-
131	85	18	24	5	-	-	-
142	91	18	24	4	-	-	-
154	100	18	24	4	-	-	-
159	112	31	24	6	-	-	-
170	118	31	24	6	-	-	-
184	124	31	24	-	6	-	-
195	130	31	36	-	5	-	-
206	136	31	36	-	5	-	-
217	142	31	36	-	-	5	-
231	148	31	36	-	-	4	-
239	154	31	36	-	-	4	-
247	158	31	36	-	-	-	4

STEEL ARCH PIPE

 STANDARD ROAD PLAN	REVISION	
	1	04-19-16
	DR-104	
SHEET 3 of 3		
REVISIONS: Added general note regarding maximum cover on concrete arch pipes.		
 APPROVED BY DESIGN METHODS ENGINEER		

**DEPTH OF COVER TABLES
FOR CONCRETE AND CORRUGATED PIPE**

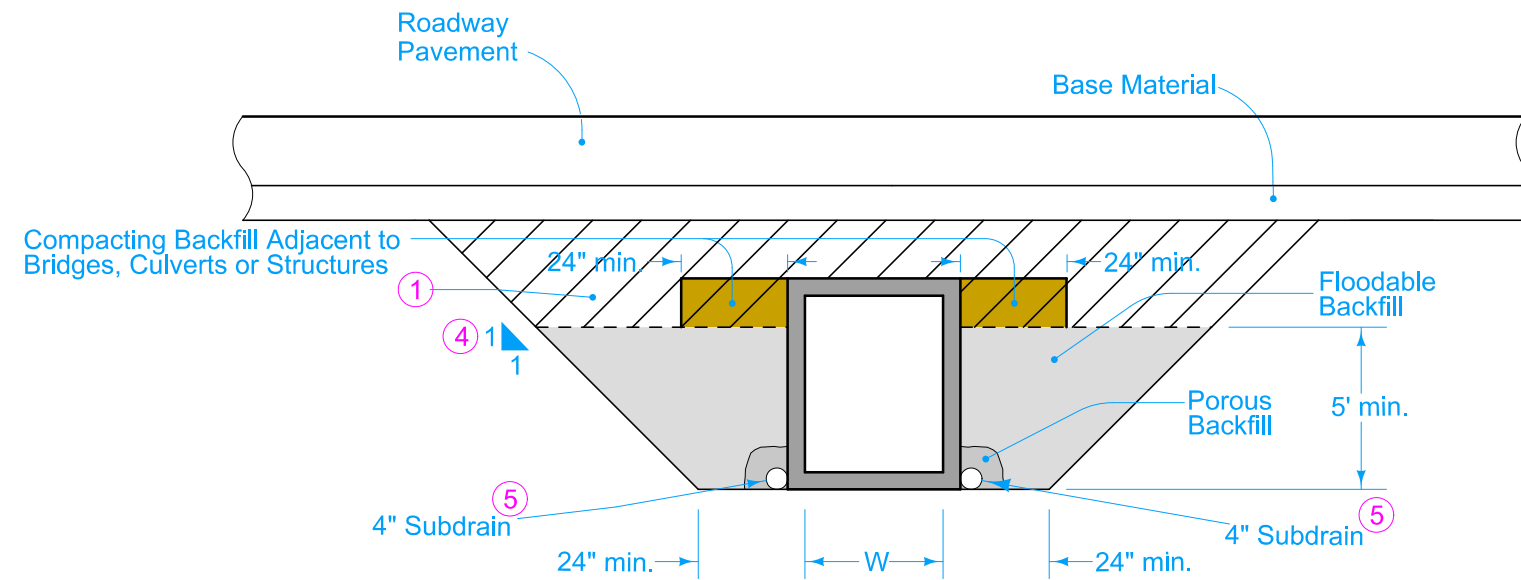

RCB INSTALLATION

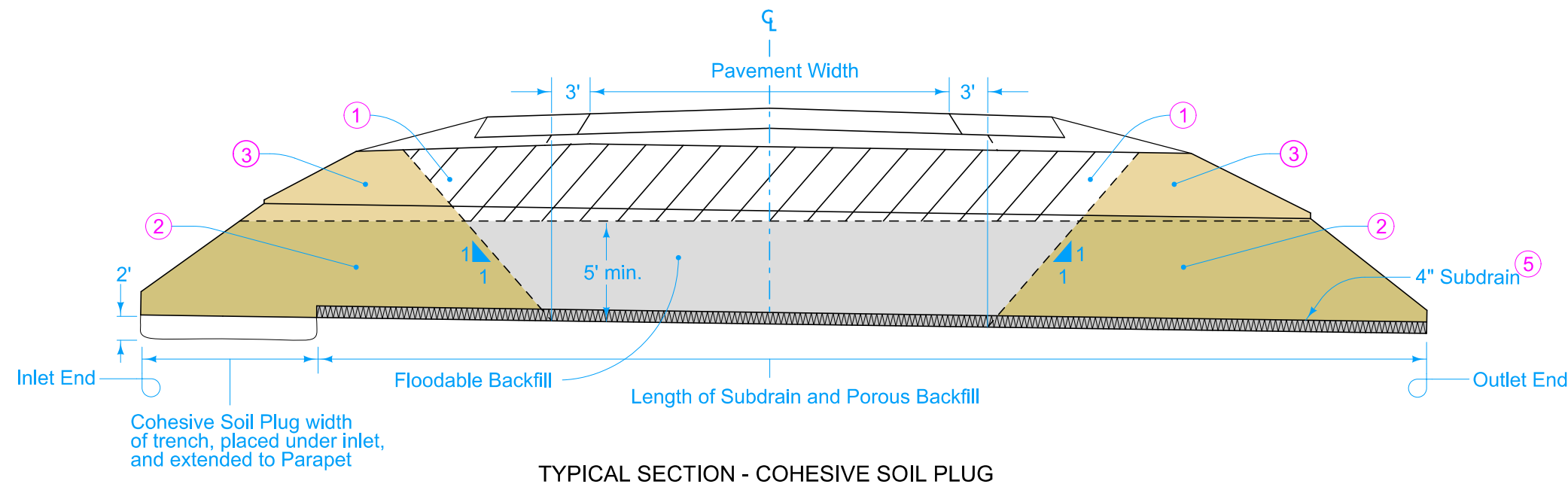

TYPICAL SECTION - COHESIVE SOIL PLUG

- ① Excavated material meeting the requirements of the Standard Specifications. Compact using moisture control. The Contractor has the option to use Floodable Backfill. No additional compensation will be provided if the Contractor elects to use Floodable Backfill in lieu of suitable soil.
- ② Prior to flooding, place a cohesive soil plug to the height of the floodable backfill at the inlet, outlet and sides of the culvert.
- ③ Excavated material meeting the requirements of the Standard Specifications. Compact using moisture control. If the option to use Floodable Backfill to the top of subgrade is used, extend the cohesive soil plug to the top of subgrade.
- ④ Quantity calculations for payment are based on a 1:1 slope and minimum trench dimension. Actual slope of trench may vary based upon Contractor's operations. No additional payment will be made for additional quantities resulting from use of flatter slopes.
- ⑤ Place at flowline elevation of culvert starting at parapet for inlet and outletting at end of outlet headwall wings. Cover with a minimum of 4 inches of Porous Backfill.

Possible Contract Items:

- Flooded Backfill
- Excavation, Class 20
- Compaction with Moisture Control
- Compacting Backfill Adjacent to Bridges, Culverts or Structures

Possible Tabulations:

- 103-6
- 104-4

Denotes pay limits for flooded backfill

 STANDARD ROAD PLAN	REVISION	
	2	04-17-18
DR-111		SHEET 1 of 1

REVISIONS: Added Compacting Backfill Adjacent to Bridges, Culverts or Structures to Possible Contract Items and RCB Installation detail. Revised notes 3 and 4.

Shawn Miller
APPROVED BY DESIGN METHODS ENGINEER

**BOX CULVERT
(BACKFILL)**

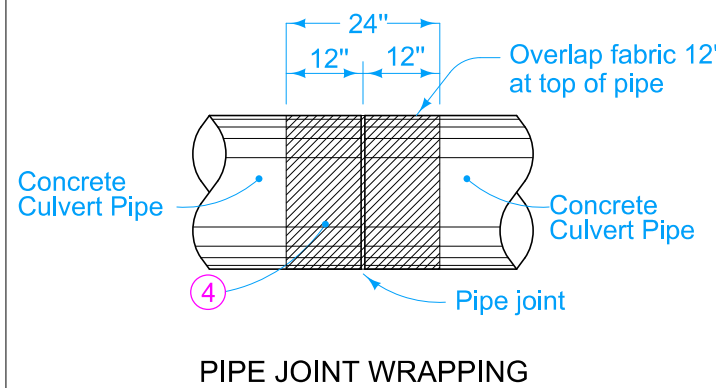
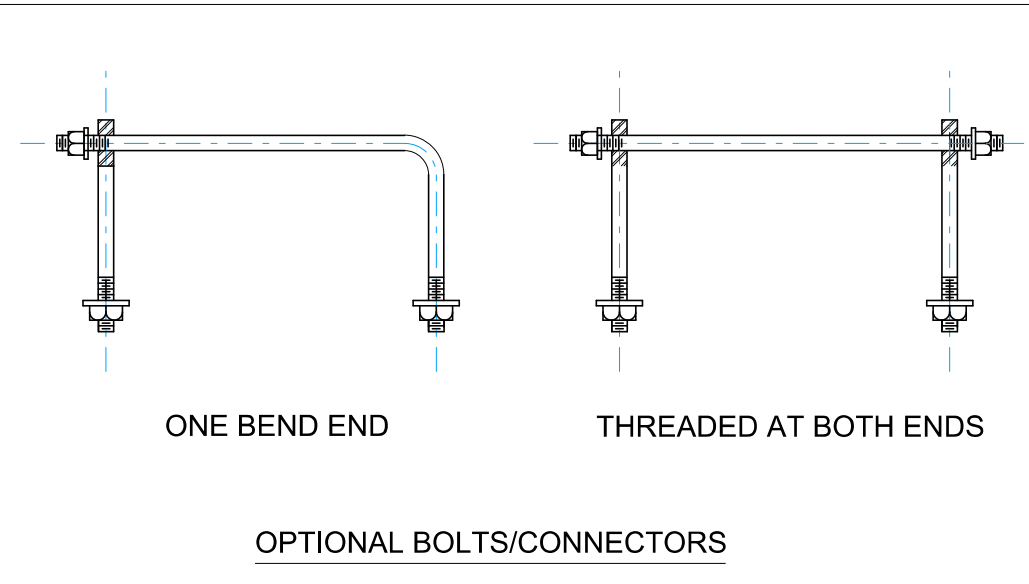
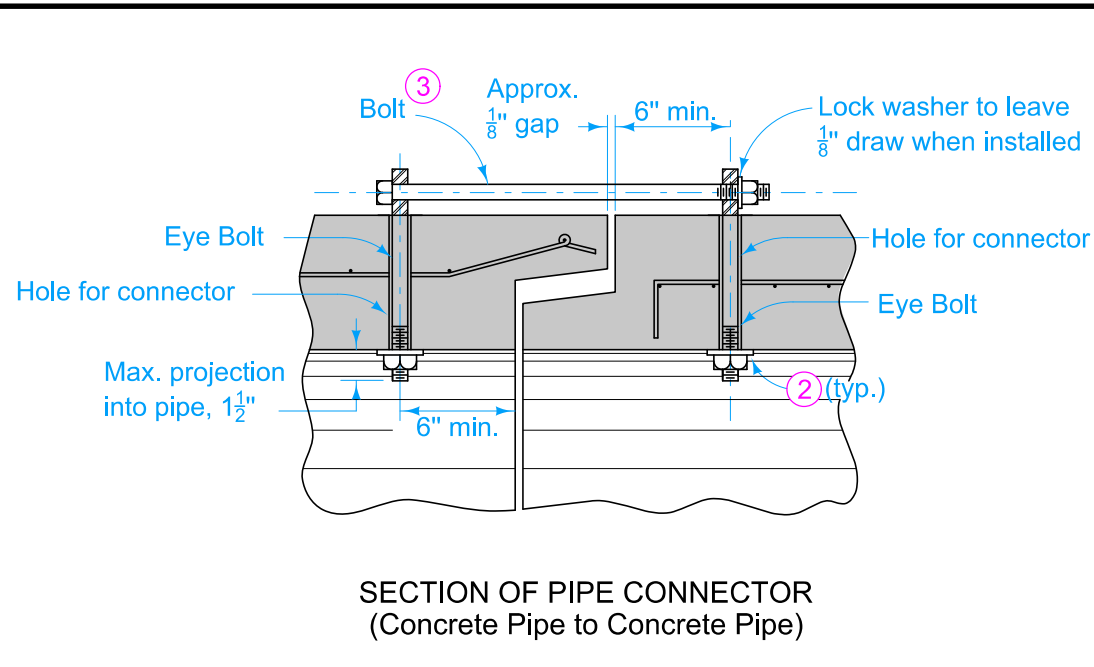
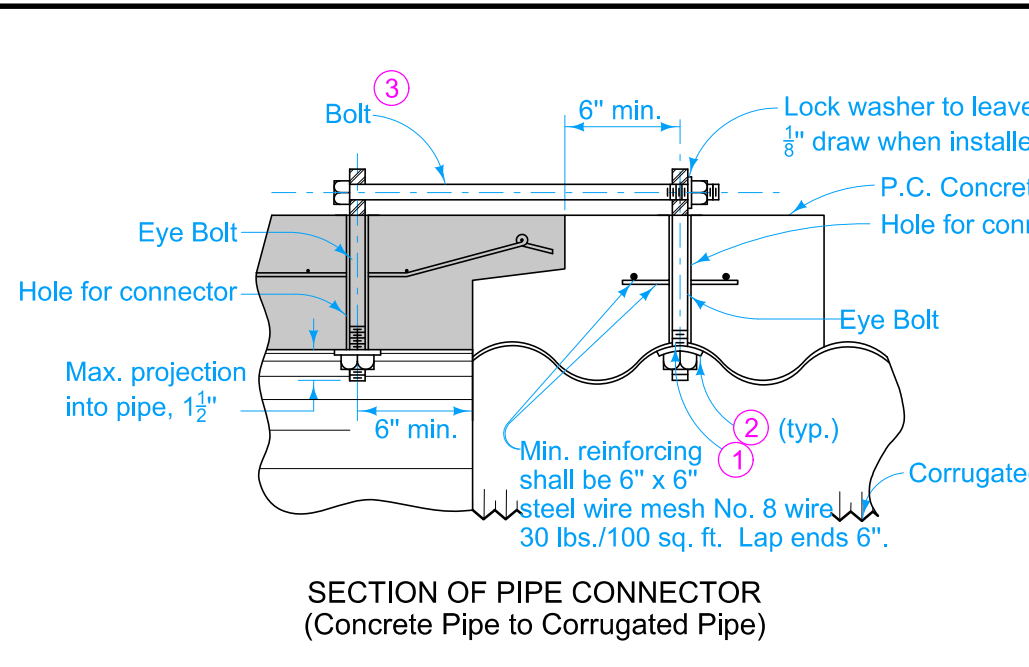

PIPE SIZE (in)	CONNECTOR AND BOLT SIZE (in.)	HOLE FOR CONNECTOR (in.)
12 to 27	5/8	7/8
30 to 60	3/4	1.0
66 to 132	1.0	1 1/4

Wrap all joints on concrete roadway pipe culverts.
Use Type 3 Connections on all culvert pipes, unless specified otherwise. Refer to Materials I.M. 445.01 for Connector requirements.

Minimum 2 threads showing at all threaded ends.
Connections not required on pipe sections installed by trenchless methods.

For belled concrete pipe joints, connectors may be installed on the inside of the pipe.

TYPE 1
One connector at the top of the pipe section.

TYPE 2 (Sealed Joint)
Two connectors near the top of the pipe section. For details of reinforcement, refer to AASHTO M 170 for the class of pipe required. Refer to Materials I.M. 491.09 for seal requirements.

TYPE 3 (Non - Sealed Joint)
Two connectors near the top of the pipe section. For details of reinforcement, refer to AASHTO M 170 for the class of pipe required.

(1) If holes are field drilled, place a ribbon of butyl sealant around bolts before placing 3 in. x 3 in. x 1/4 in. plate on bolts through corrugated metal pipe and tightening nuts.

(2) 1 3/4 inch round x 9/64 inch thick washer or 3 in. x 3 in. x 1/4 in. square plate (shaped to pipe radius).

(3) Connectors with One Bend End and Bell End spacers allowed per Materials I.M. 451. Refer to Optional Bolts detail.

(4) Engineering fabric for embankment erosion control.

Possible Tabulations:
104-3
104-5B

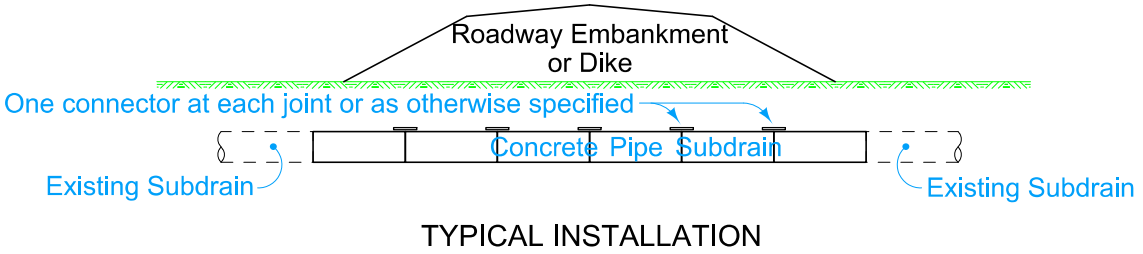
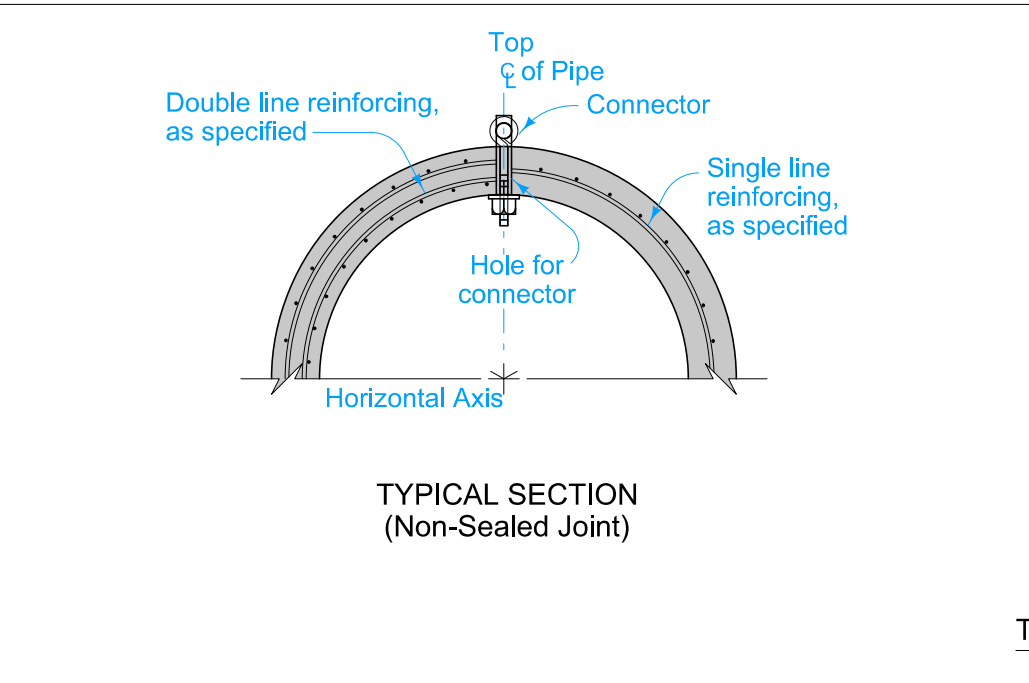

TYPE 1 CONNECTION

	REVISION	
	4	04-18-23
STANDARD ROAD PLAN		DR-121
REVISIONS: Corrected title.		SHEET 1 of 2
 APPROVED BY DESIGN METHODS ENGINEER		
CONNECTED PIPE JOINTS		

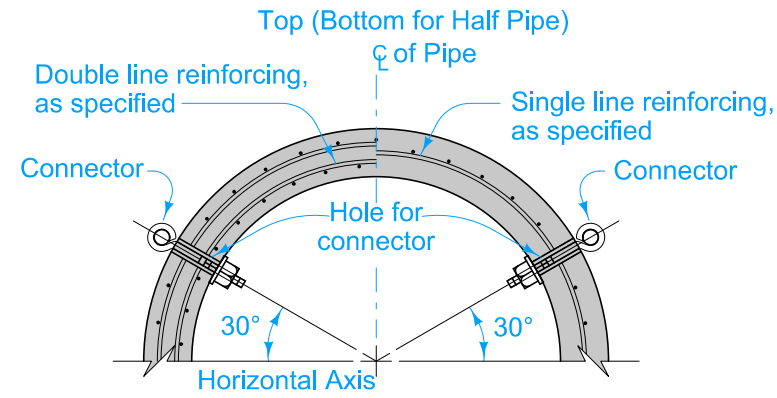

TYPICAL SECTION
 TYPE 2 CONNECTION
 TYPE 3 CONNECTION

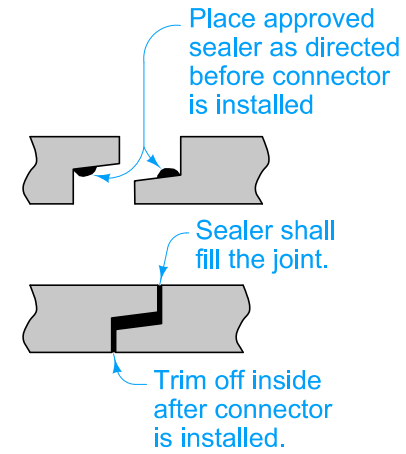

SEALED JOINT
 TYPE 2 CONNECTION

5 On culvert extensions, connect all new joints including the joint between the old and new culvert pipe. Holes may need to be drilled into existing pipes.

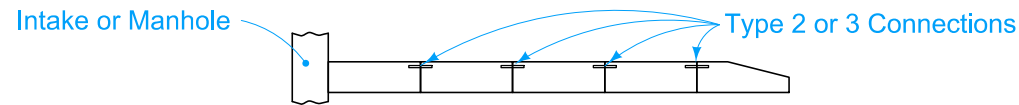

TYPICAL INSTALLATION
 STORM SEWER OUTLET - TYPE 2 OR TYPE 3 CONNECTION

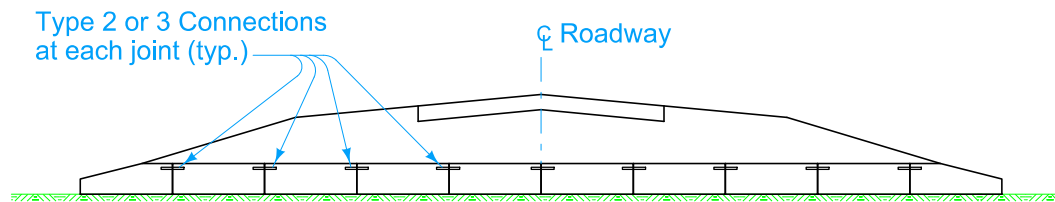

TYPICAL INSTALLATION
 NEW CONSTRUCTION - TYPE 2 or 3 CONNECTION

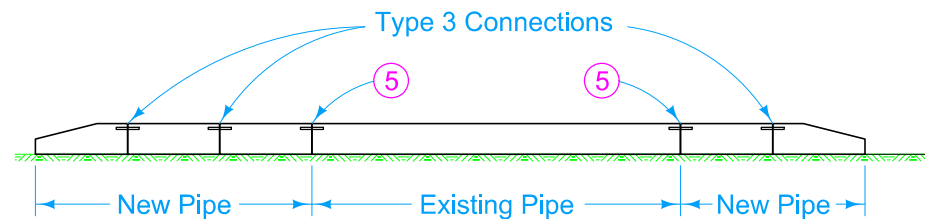

TYPICAL INSTALLATION
 PIPE EXTENSION - TYPE 3 CONNECTION

TYPE 2 AND TYPE 3 CONNECTIONS

	REVISION	
	4	04-18-23
STANDARD ROAD PLAN		DR-121
REVISIONS: Corrected title.		SHEET 2 of 2

APPROVED BY DESIGN METHODS ENGINEER

CONNECTED PIPE JOINTS

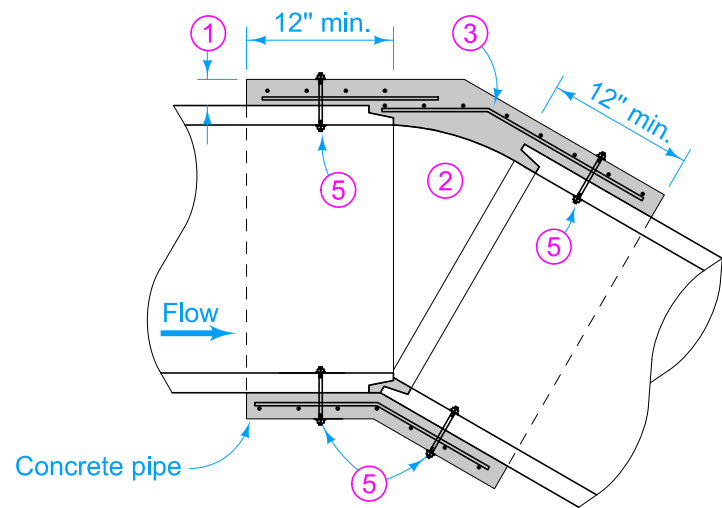

CONCRETE PIPE TO CONCRETE PIPE
TYPE "C-1"

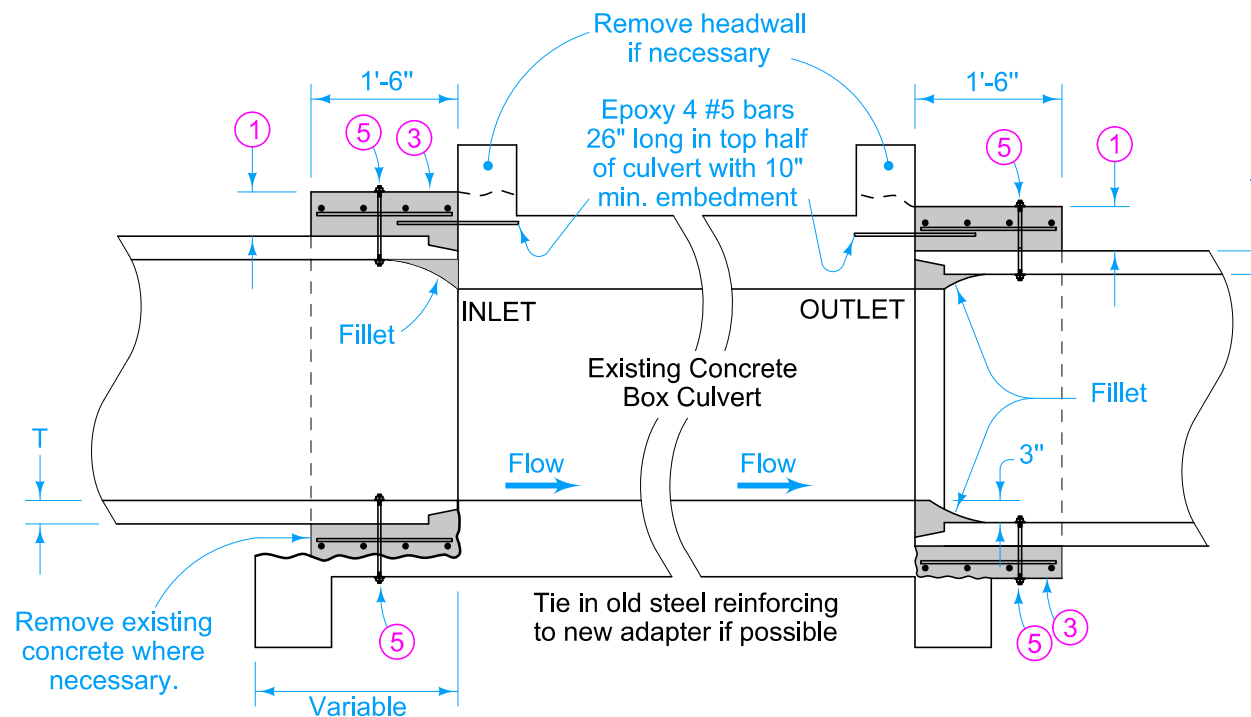

CONCRETE PIPE TO CONCRETE BOX CULVERT
TYPE "C-2"

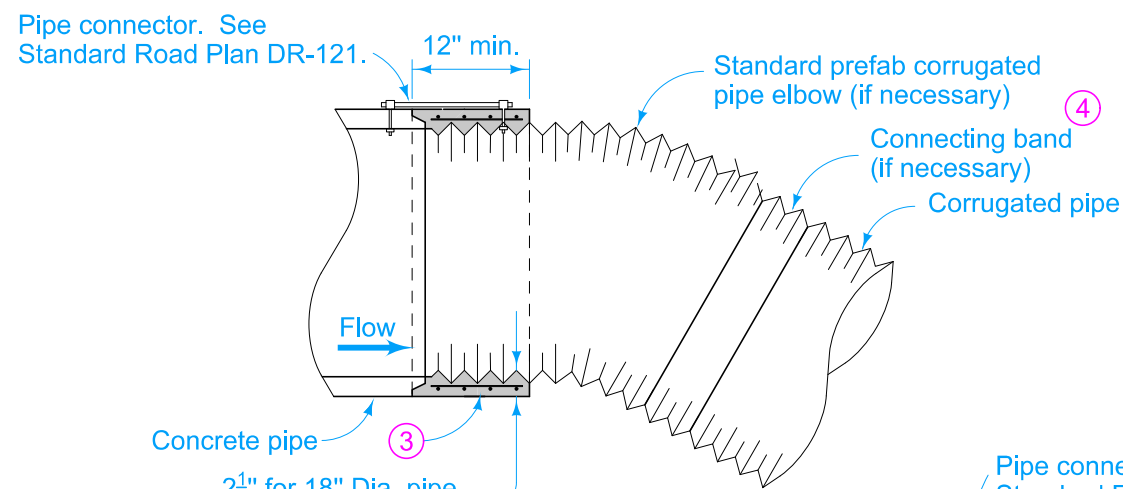

CONCRETE PIPE TO CORRUGATED PIPE
TYPE "C-3"

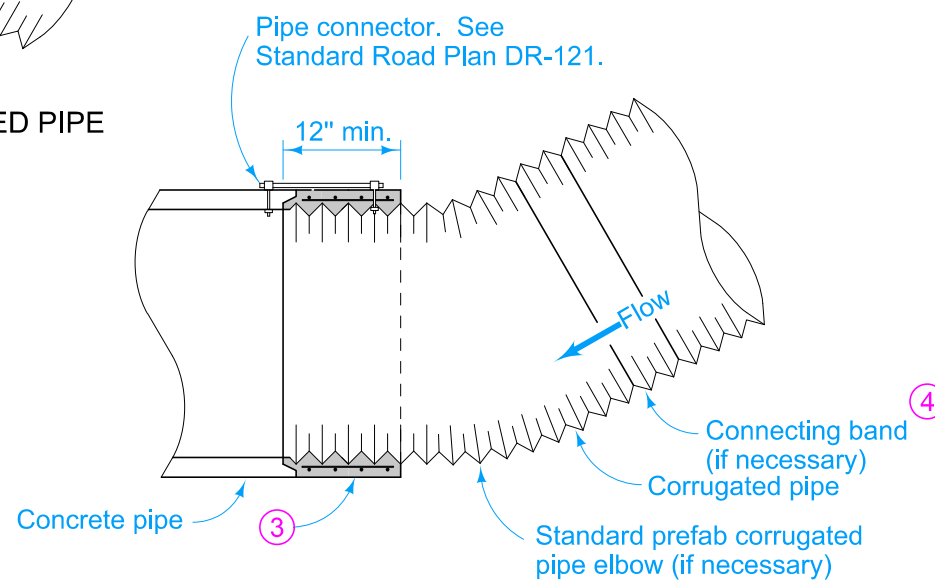

CORRUGATED PIPE TO CONCRETE PIPE
TYPE "C-4"

ESTIMATED ENCASEMENT QUANTITIES PER LINEAR FOOT FOR "C-2" ADAPTORS			
Diameter, D inches	Concrete cu. yds.	Wire Mesh lbs.	Concrete for Fillet ("C-2") cu. yds.
15	0.1	2.0	N.A.
18	0.1	2.3	N.A.
21	0.1	2.6	N.A.
24	0.1	2.8	N.A.
30	0.2	3.4	0.1
36	0.2	4.0	0.1
42	0.2	4.5	0.1
48	0.3	5.1	0.1
54	0.3	5.7	0.1
60	0.4	6.2	0.1
66	0.5	6.9	0.1
72	0.6	7.5	0.1
78	0.6	8.1	0.1
84	0.7	8.7	0.1

2000 D (Class III) and 3000 D (Class IV) Pipe

No payment will be made for individual adaptors.

The cost of furnishing all materials and constructing adaptor as indicated is incidental to the pipe culvert.

Removal and disposal of headwall, wingwall, or other concrete, as directed, will be paid for as "Removal of Existing Structures".

Form and construct Type "C-1" and "C-2" adaptors on the job site using methods approved by the Engineer.

Type "C-3" and "C-4" adaptors may be shop fabricated using a method approved by the Engineer for attaching a concrete collar (either tongue or groove end) to a standard section of corrugated pipe. Holes may be field drilled in corrugated pipe to match alignment with concrete pipe.

- ① Thickness same as pipe thickness (T) but not less than 4 inches.
- ② Grout opening between pipes.
- ③ Use minimum reinforcing of wire mesh 6" x 6" - W2 No. 8 wire - 30lbs/100 sq. ft. Lap ends 6 inches.
- ④ Positive type joint coupling required.
- ⑤ 5/8 inch (min.) bolts in 7/8 inch (min.) holes. Four bolts around each connection at equal intervals. Existing pipe connector holes may be used if available. Place remaining two bolts at approximate equal intervals.

T Thickness of wall of concrete pipe. See AASHTO M 170.

	REVISION	
	1	10-18-16
STANDARD ROAD PLAN		DR-122
REVISIONS: Corrected two typos in general notes.		SHEET 1 of 1
 APPROVED BY DESIGN METHODS ENGINEER		
CONSTRUCTION OF TYPE 'C' CONCRETE ADAPTERS FOR PIPE CULVERT CONNECTIONS		

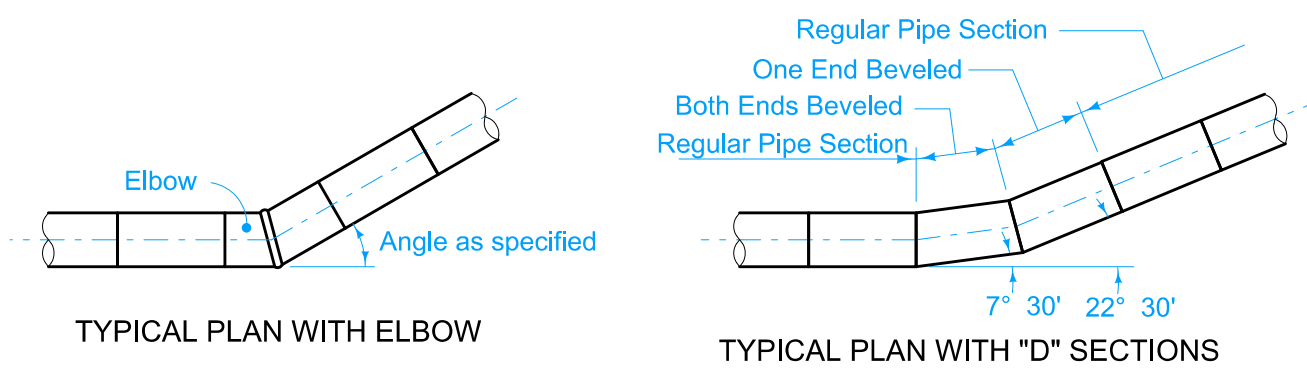

REINFORCING BARS		
Size "D"	Bar Size	Number Required
12" - 21"	#3	4
24" - 42"	#4	8
48" - 60"	#5	8
66" - 84"	#6	8

Fabricate concrete pipe elbows and Type "D" pipe sections according to AASHTO M 170 for the size and class of pipe specified. Meet the requirements of AASHTO M 32 for wire reinforcing.

Unless specified otherwise, bevel the Type "D" section on a 7.5 degree miter. The bevel may be provided on either the tongue end or groove end of the pipe. In certain cases, both ends of the pipe section may require the beveled end.

Type "D" pipe sections will be included in the measurement for pipe culvert. No payment will be made specifically for the Type "D" section bevel. This is incidental to the price bid.

The Contractor may substitute an approved elbow for "D" section bends of 15 degrees or less. Such elbows will not be measured for payment but will be considered incidental to price bid for culvert pipe.

Refer to the plans for degree of elbow required for each individual installation. Minimum length of elbow is to be 5'-6" measured along centerline of pipe. Design length of pipe will be considered to be 6'-0".

Fabricate elbows using a method approved by the Engineer and which results in a finished product indicated hereon. The typical method for fabricating elbows is as follows: Steel rods, as specified, are attached to the normal wire reinforcing cage as indicated hereon. After pipe is cast, make a cut 50% of the degree of elbow desired as indicated and cut the reinforcing rods and mesh on centerline of the cut. Rotate the severed section of pipe 180 degrees and reweld the reinforcing to the opposite rods. Patch the remaining opening with cement mortar to complete a satisfactorily completed elbow as shown.

For pipe sizes up through 48" in diameter, bends may be accomplished in increments of 7.5 degrees by using standard "D" sections in appropriate combinations.

For pipe sizes from 54" to 72" in diameter, limit the "D" section to a maximum of 5 degree miter on any one end of pipe section.

For pipe sizes through 48" in diameter, bends from 15 to 45 degrees may be accomplished using a single elbow. Bends more than 45 degrees require two elbows unless approved otherwise by the Engineer.

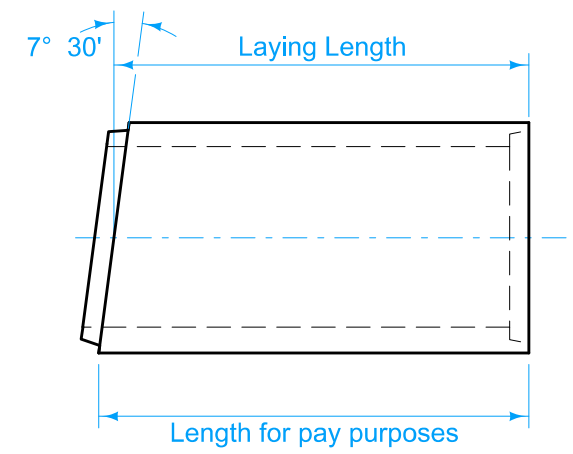

TYPE "D" SECTION (SINGLE BEVEL)

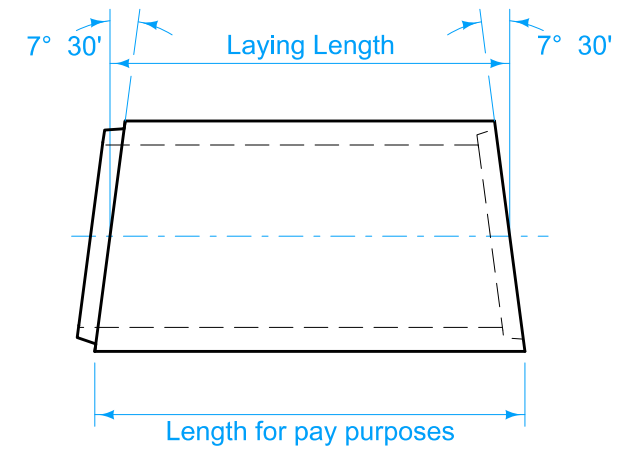

TYPE "D" SECTION (DOUBLE BEVEL)

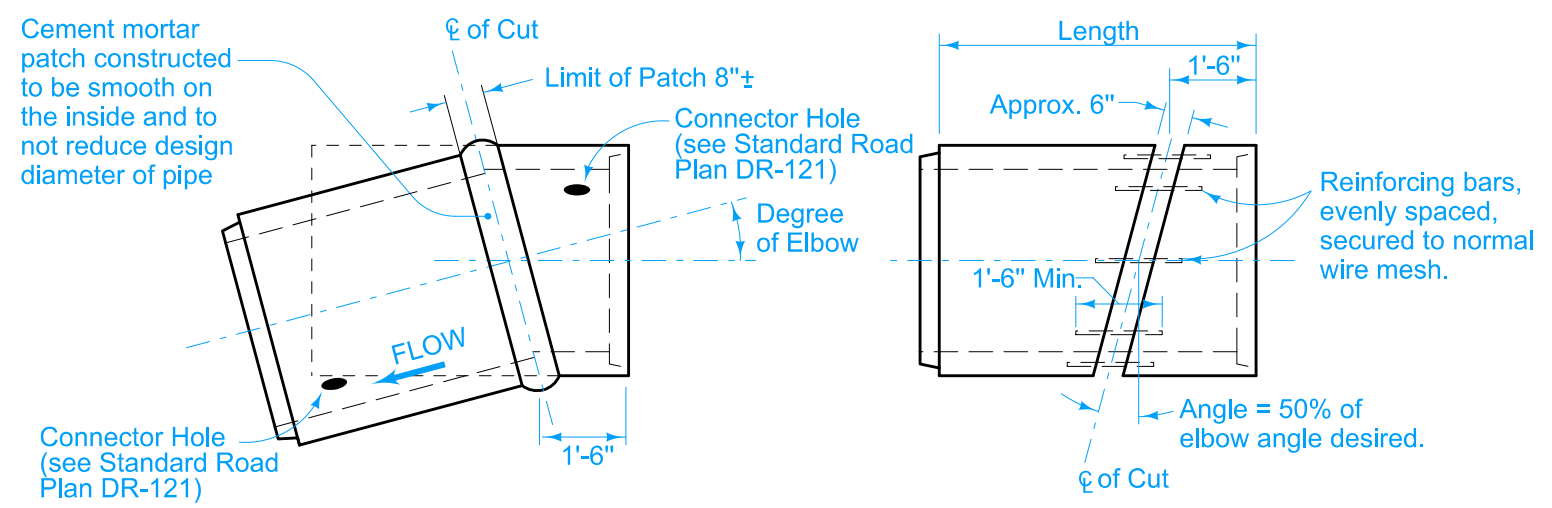

TYPICAL CONCRETE PIPE ELBOW

Possible Tabulation:
104-3

	REVISION	
	1	04-18-17
STANDARD ROAD PLAN		DR-141
		SHEET 1 of 1
REVISIONS: Changed title from PIPE BENDS AND HALF PIPE to PIPE BENDS. Removed DETAILS OF HALF PIPE SECTION view. Removed references to Half Pipe in Notes.		
APPROVED BY DESIGN METHODS ENGINEER		
PIPE BENDS		

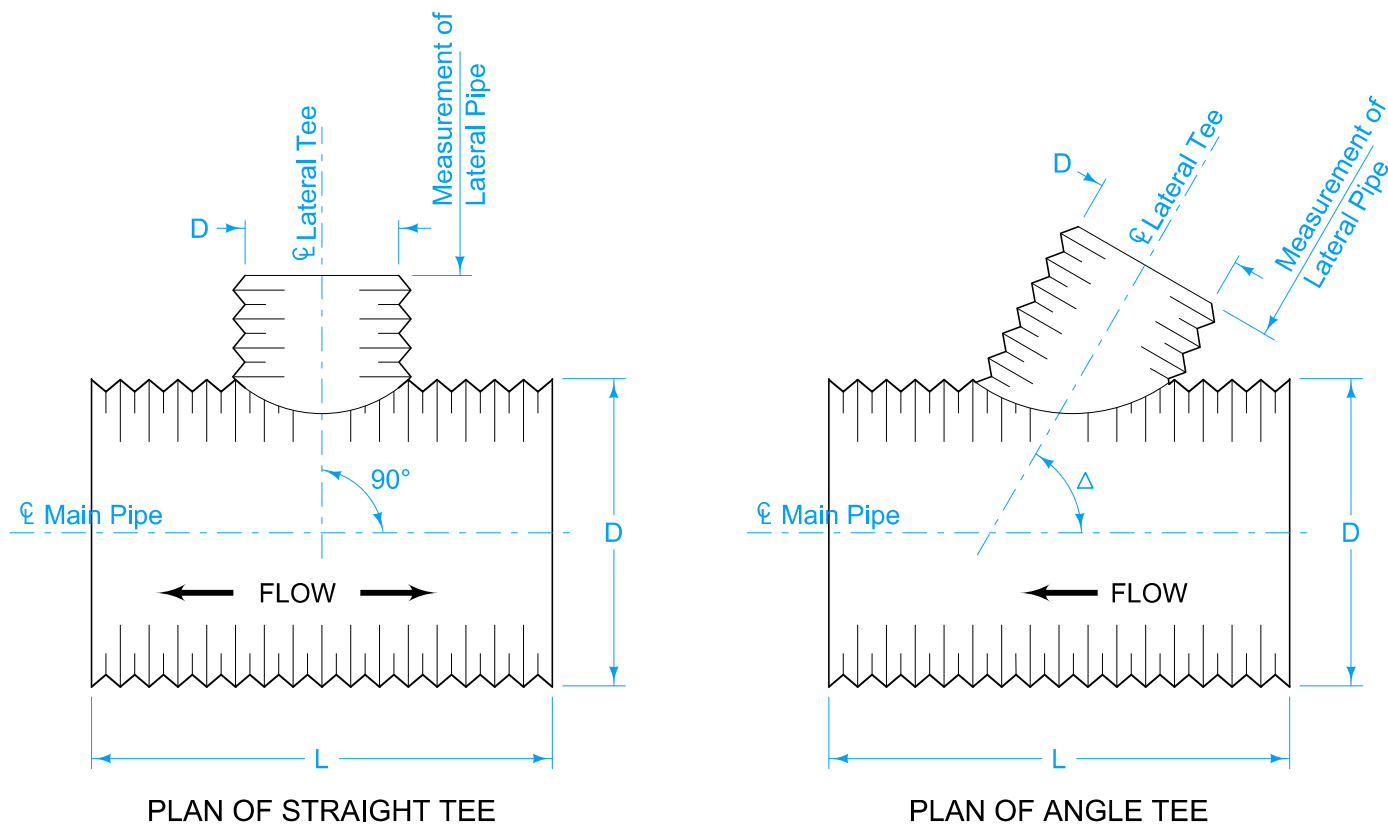

CORRUGATED METAL PIPE

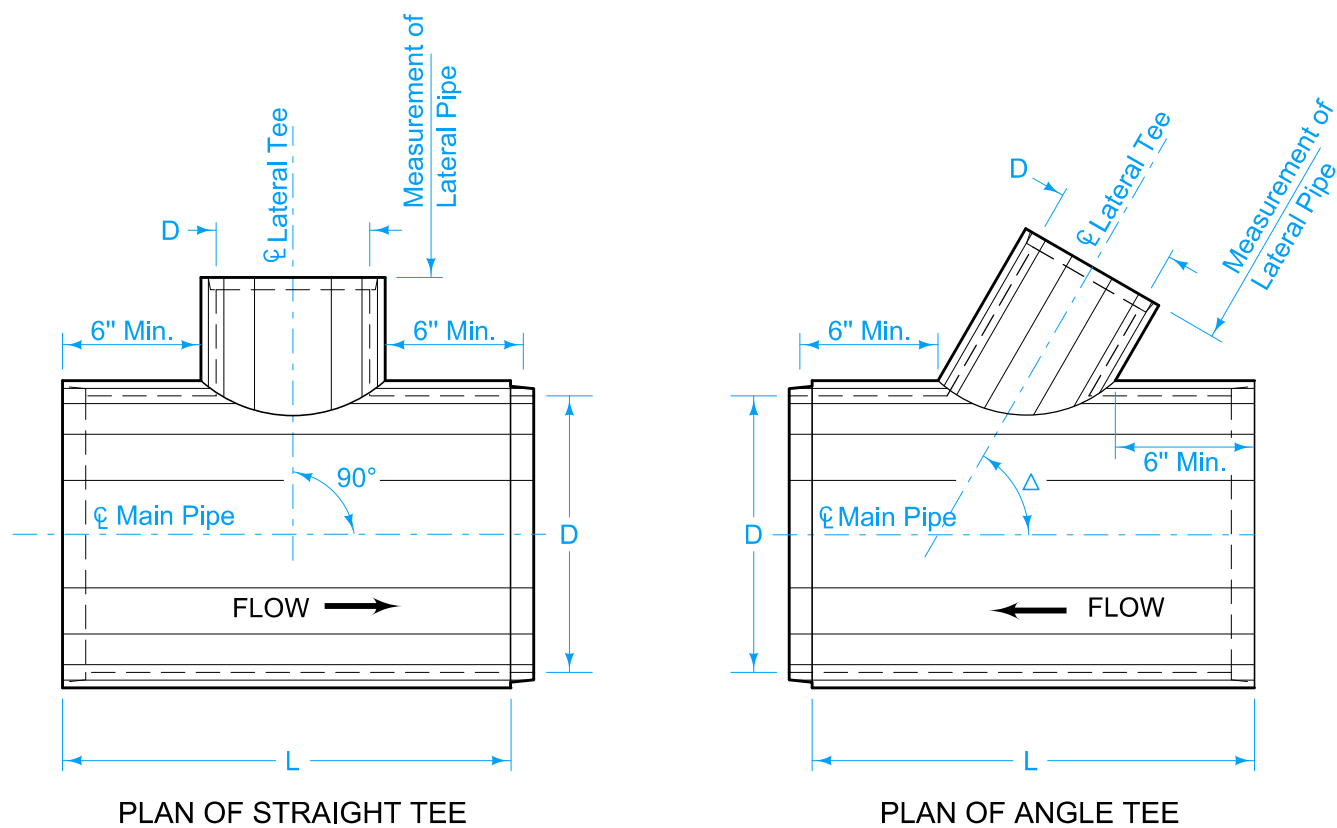

CONCRETE PIPE

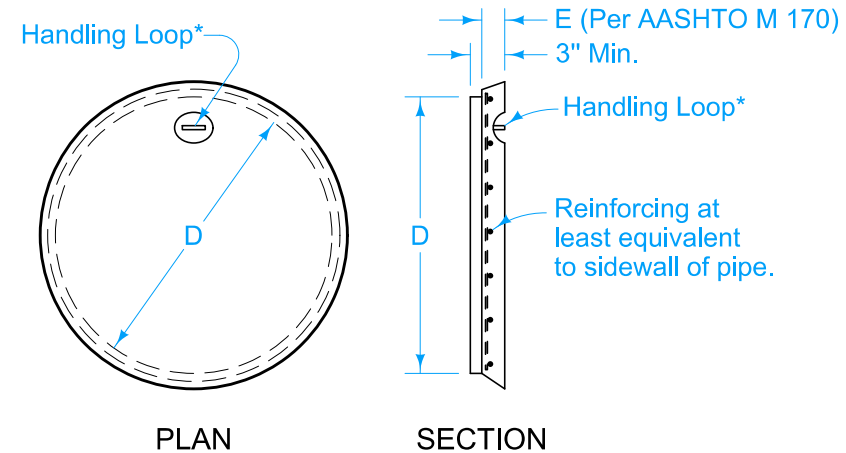

DETAILS OF CONCRETE PIPE CAP
 *The handling loop may be omitted when the cap is placed in a buried installation.

Tees may be required in any size from 12 inch diameter to 48 inch diameter (in 6 inch increments) on main pipe culverts equal to or greater in diameter than that of the tee. Angle tees may be required in any delta angle (of 5 degree increment) between 45 and 90 degrees. Consider a tee section delta angle 90 degrees (straight tees) unless noted otherwise in the project plans.

Example: "18-36 inch Tee" means an 18 inch diameter 90 degree lateral tee attached to a 36 inch main pipe culvert.

Example: "24-48 inch 75 degree Tee" means a 24 inch diameter lateral tee attached to a 48 inch main pipe culvert at an angle of 75 degrees.

Fabricate the tee in such a manner as to be as free from obstruction on the inside of the pipe as is reasonable. Use a method approved by the Engineer.

CORRUGATED METAL PIPE TEE:
 Repair damage to protective coating resulting from installation of culvert as directed by the Engineer.

CONCRETE PIPE TEE:
 Length of main pipe section (L) is a minimum of 4 feet and a maximum of 8 feet. The length of main pipe section will be included in the measured length of structure.

CONCRETE PIPE CAP:
 The use of an approved pipe cap is required when so indicated on the detail project plans. Ensure the dimensions of the pipe cap are such that the pipe cap neatly fits the groove end of the appropriate size of culvert pipe.

The cap may be precast or it may be cast directly into the pipe end with a tight mortar joint between the cap and the pipe. Place an approved bituminous joint material between the cap and the pipe if the cap is positioned at the construction site.

Installation of pipe cap is incidental to other pipe culvert work on the project.

	REVISION	
	1	10-19-21
STANDARD ROAD PLAN		DR-142
		SHEET 1 of 1
REVISIONS: Modified Concrete Pipe Tee note to maximum 8 feet.		
APPROVED BY DESIGN METHODS ENGINEER		
CULVERT PIPE TEE SECTIONS		

DESIGNER INFORMATION

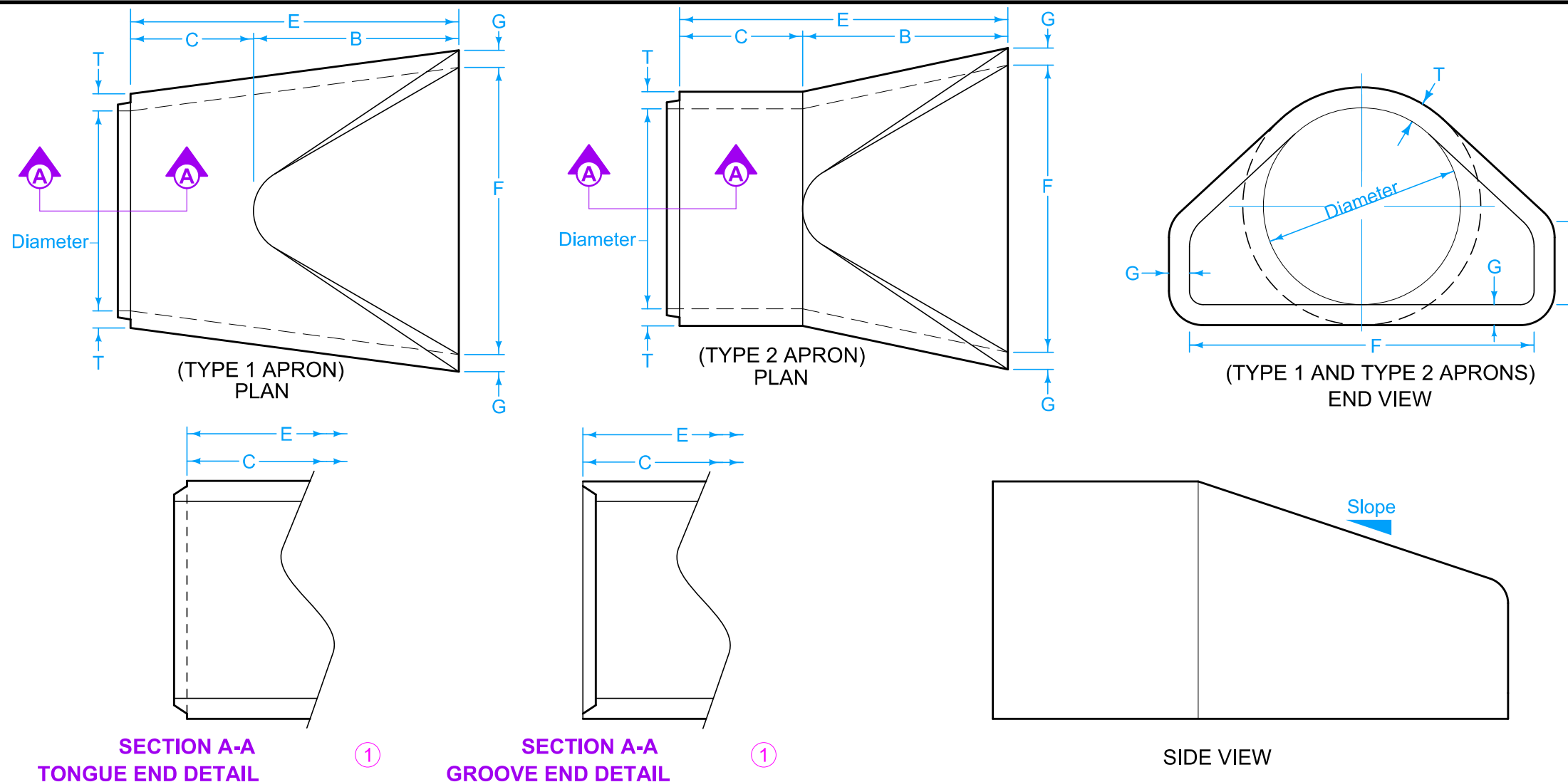

Dimension 'E' shown is the minimum and is considered the design length. Adjust for any difference between the actual length of concrete apron installed and the length indicated hereon within the length of concrete culvert pipe furnished.

Install connected pipe joints as shown on DR-121.

When specified in the contract documents, install pipe apron guards as shown on DR-213. Pipe apron guards are incidental to "Concrete Aprons".

Slight variations in both shape and dimensions from those shown may be accepted if approved by the engineer.

① Tongue end used on inlet end section. Groove end used on outlet end section.

TYPE 1 APRONS								
DIAM.	SLOPE	A	B	MINIMUM		F	G	T
				C	E			
12"	2.4:1	4"	2'-0"	4'- ⁷ / ₈ "	6'- ⁷ / ₈ "	2'-0"	2"	2"
15"	2.4:1	6"	2'-3"	3'-10"	6'-1"	2'-6"	2 ¹ / ₄ "	2 ¹ / ₄ "
18"	2.3:1	9"	2'-3"	3'-10"	6'-1"	3'-0" *	2 ¹ / ₂ "	2 ¹ / ₂ "
21"	2.4:1	9"	3'-0"	3'-1 ¹ / ₂ "	6'-1 ¹ / ₂ "	3'-5"	3"	3"
24"	2.5:1	9 ¹ / ₂ "	3'-7 ¹ / ₂ "	2'-6"	6'-1 ¹ / ₂ "	4'-0"	3"	3"
27"	2.5:1	10 ¹ / ₂ "	4'-1"	2'-0"	6'-1 ¹ / ₂ "	4'-4"	3 ¹ / ₂ "	3 ¹ / ₂ "
30"	2.5:1	12"	4'-6"	1'-7 ³ / ₄ "	6'-1 ³ / ₄ "	5'-0"	3 ¹ / ₂ "	3 ¹ / ₂ "
36"	2.5:1	15"	5'-3"	2'-9"	8'-0"	6'-0"	4"	4"
42"	2.5:1	21"	5'-3"	2'-9"	8'-0"	6'-6"	4 ¹ / ₂ "	4 ¹ / ₂ "
48"	2.5:1	24"	6'-0"	2'-0"	8'-0"	7'-0"	5"	5"
54"	1.8:1	27"	5'-0"	3'-0"	8'-0"	7'-6"	5 ¹ / ₂ "	5 ¹ / ₂ "
60"	1.6:1	29 ¹ / ₂ "	5'-0"	3'-0"	8'-0"	8'-0"	5 ¹ / ₂ "	6"
66"	1.7:1	30"	6'-0"	2'-3"	8'-3"	8'-0"	5 ¹ / ₂ "	6"
72"	1.6:1	30"	6'-6"	1'-9"	8'-3"	9'-0"	6"	7"
78"	1.8:1	36"	7'-6"	1'-9"	9'-3"	9'-6"	6 ¹ / ₂ "	7 ¹ / ₂ "
84"	1.3:1	29 ¹ / ₂ "	6'-9"	2'-6 ¹ / ₂ "	9'-3 ¹ / ₂ "	10'-0"	6 ¹ / ₂ "	8"

TYPE 2 APRONS								
DIAM.	SLOPE	A	B	MINIMUM		F	G	T
				C	E			
12"	2.4:1	4"	2'-0"	4'- ⁷ / ₈ "	6'- ⁷ / ₈ "	2'-0"	2"	2"
15"	2.4:1	6"	2'-3"	3'-10"	6'-1"	2'-6"	2 ¹ / ₄ "	2 ¹ / ₄ "
18"	2.3:1	9"	2'-3"	3'-10"	6'-1"	3'-0" *	2 ¹ / ₂ "	2 ¹ / ₂ "
21"	2.4:1	9"	3'-0"	3'-1 ¹ / ₂ "	6'-1 ¹ / ₂ "	3'-5"	3"	3"
24"	2.5:1	9 ¹ / ₂ "	3'-7 ¹ / ₂ "	2'-6"	6'-1 ¹ / ₂ "	4'-0"	3"	3"
27"	2.5:1	10 ¹ / ₂ "	4'-1"	2'-0"	6'-1 ¹ / ₂ "	4'-4"	3 ¹ / ₂ "	3 ¹ / ₂ "
30"	2.5:1	12"	4'-6"	1'-7 ³ / ₄ "	6'-1 ³ / ₄ "	5'-0"	3 ¹ / ₂ "	3 ¹ / ₂ "
36"	2.5:1	15"	5'-3"	2'-9"	8'-0"	6'-0"	4"	4"
42"	2.5:1	21"	5'-3"	2'-9"	8'-0"	6'-6"	4 ¹ / ₂ "	4 ¹ / ₂ "
48"	2.5:1	24"	6'-0"	2'-0"	8'-0"	7'-0"	5"	5"
54"	1.9:1	24 ¹ / ₂ "	5'-5"	2'-7"	8'-0"	7'-6"	5 ¹ / ₂ "	5 ¹ / ₂ "
60"	1.4:1	24 ¹ / ₂ "	5'-0"	3'-0"	8'-0"	8'-0"	5 ¹ / ₂ "	6"
66"	1.7:1	30"	6'-0"	2'-3"	8'-3"	8'-0"	5 ¹ / ₂ "	6"
72"	1.4:1	24"	6'-6"	1'-9"	8'-3"	9'-0"	6"	7"
78"	1.8:1	36"	7'-6"	1'-9"	9'-3"	9'-6"	6 ¹ / ₂ "	7 ¹ / ₂ "
84"	1.5:1	23 ¹ / ₂ "	7'-6 ¹ / ₂ "	1'-9"	9'-3 ¹ / ₂ "	10'-0"	6 ¹ / ₂ "	8"

Contract Item:
Apron, Concrete

Tabulations:
104-3
104-5C

	REVISION	
	3	10-17-23
STANDARD ROAD PLAN		DR-201
SHEET 1 of 1		
REVISIONS: Added note about shape and dimensions.		
 APPROVED BY DESIGN METHODS ENGINEER		
CONCRETE APRONS		

DESIGNER INFORMATION

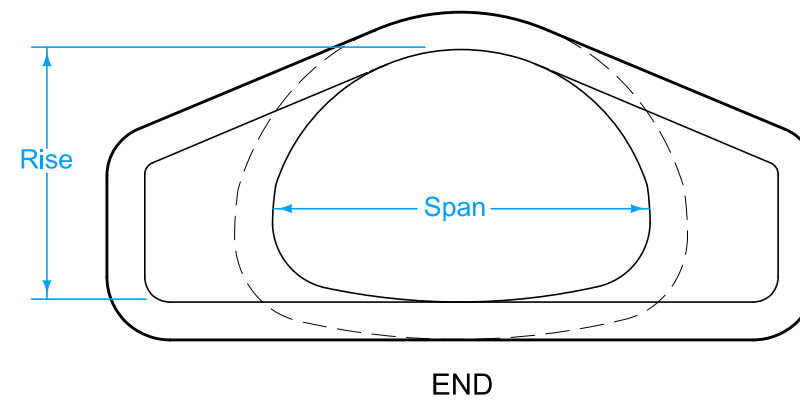
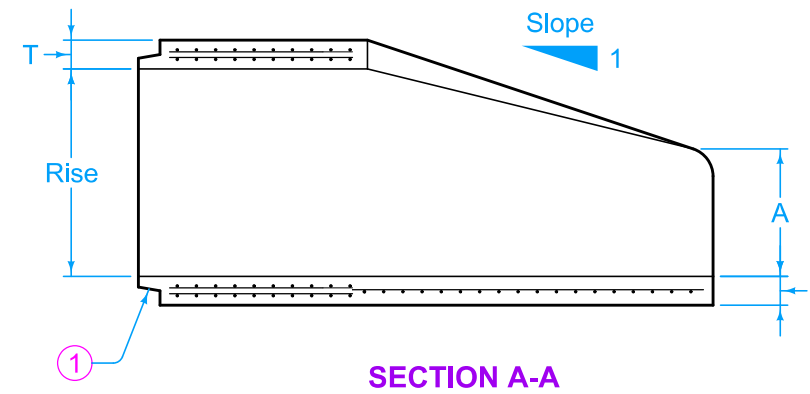
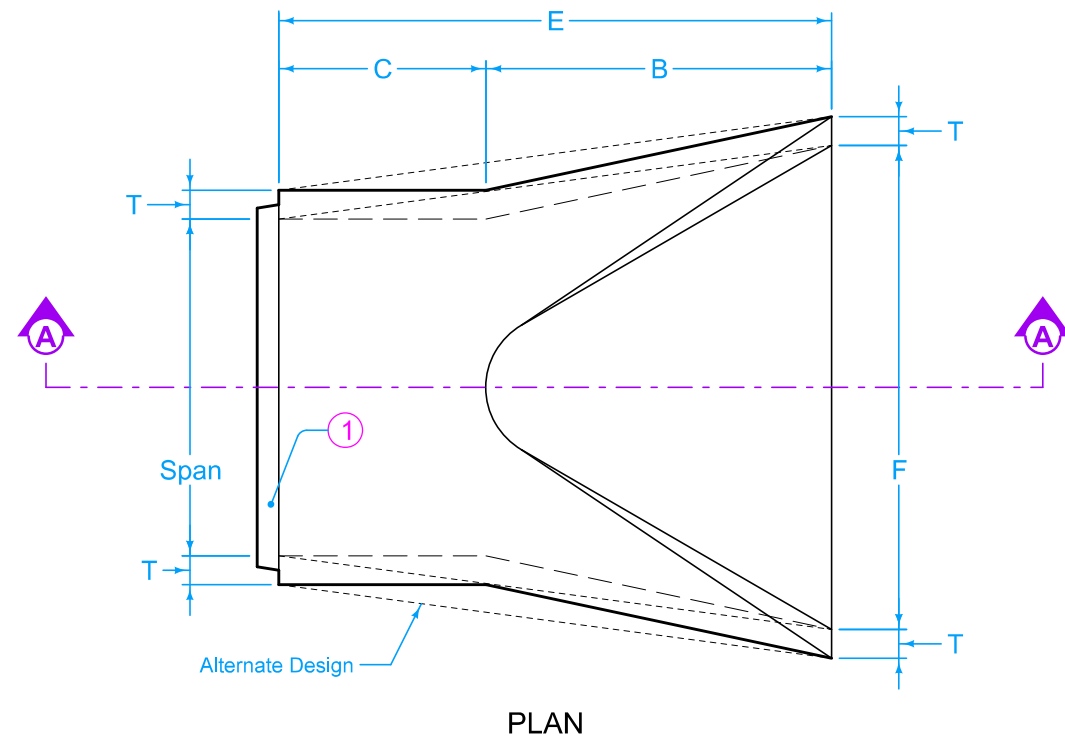

Comply with AASHTO M 206 for Apron Reinforcement.

Dimension "E" shown is minimum and is considered the design length. Appropriately adjust for any difference between the actual length of concrete apron installed and the length indicated hereon for the length of concrete culvert pipe furnished.

Install connected pipe joints as shown on DR-121.

Slight variations in both shape and dimensions from those shown may be accepted if approved by the engineer.

① Tongue end on inlet end section. Groove end on outlet end section. Inlet end section is shown.

NOMINAL DIMENSIONS SPAN X RISE Inches	EQUIVALENT DIAMETER Inches	SPAN Inches	RISE Inches	SLOPE	APPROXIMATE DIMENSIONS Inches * Maximum					
					T	A	B	C	E	F
22 X 14	18	22	13 1/2	3:1	2 1/2	7	27	45	72	36 *
29 X 18	24	28 1/2	18	3:1	3	8 1/2	39	33	72	48
37 X 23	30	36 1/4	22 1/2	3:1	3 1/2	9 1/2	50	46	96	60
44 X 27	36	43 3/8	26 5/8	3:1	4	11 1/8	60	36	96	72
52 X 32	42	51 1/8	31 5/16	3:1	4 1/2	15 13/16	60	36	96	78
59 X 36	48	58 1/2	36	3:1	5	21	60	36	96	84
65 X 40	54	65	40	3:1	5 1/2	25 1/2	60	36	96	90
73 X 45	60	73	45	3:1	6	31	60	36	96	96
88 X 54	72	88	54	2:1	7	31	60	39	99	120
102 X 62	84	102	62	2:1	8	21 1/2	83	19	102	144

ARCH PIPE

Possible Contract Item:
Low Clearance Concrete Pipe Aprons

Possible Tabulations:
104-3
104-4

	REVISION	
	2	10-17-23
STANDARD ROAD PLAN		DR-202
		SHEET 1 of 3

REVISIONS: Added note about shape and dimensions.

Steve Miller
APPROVED BY DESIGN METHODS ENGINEER

**LOW CLEARANCE
CONCRETE PIPE APRONS**

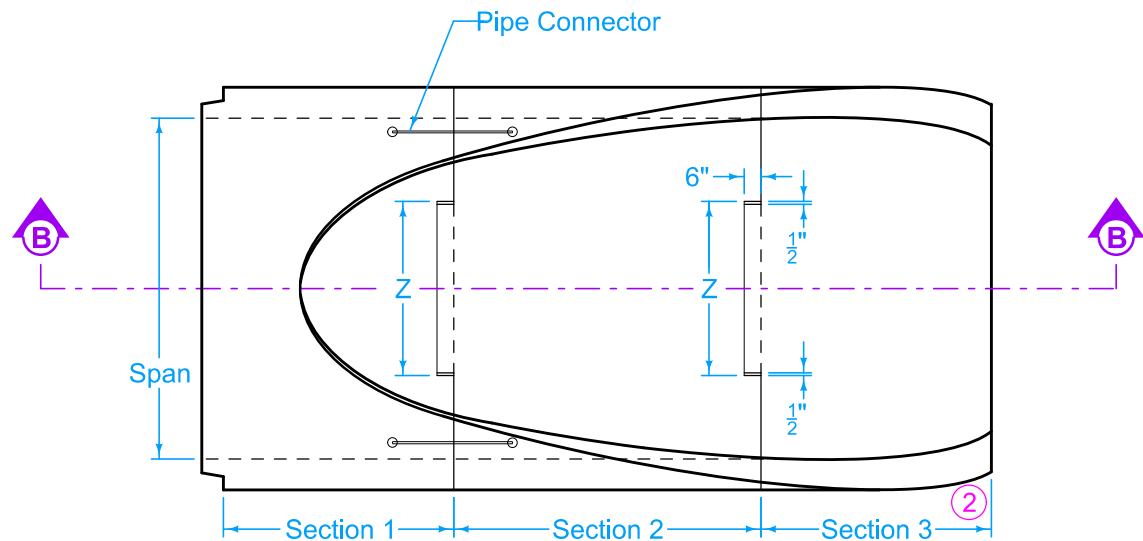

PLAN

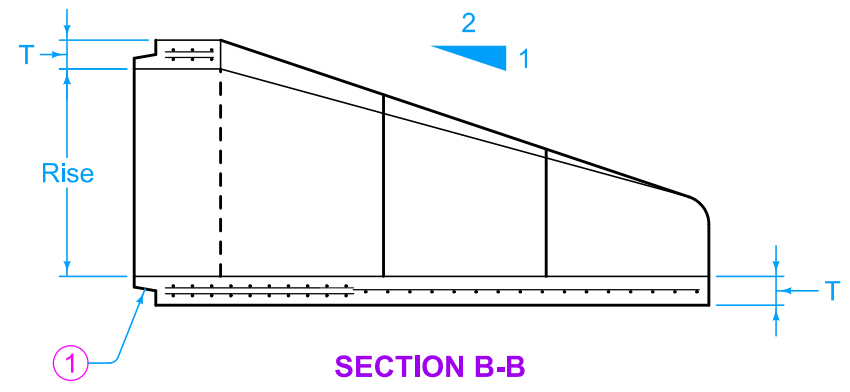

SECTION B-B

Slight variations in both shape and dimensions from those shown may be accepted if approved by the engineer.

- ① Tongue end on inlet end section. Groove end on outlet end section. Inlet end section is shown.
- ② 132 inch size is a three piece end section.

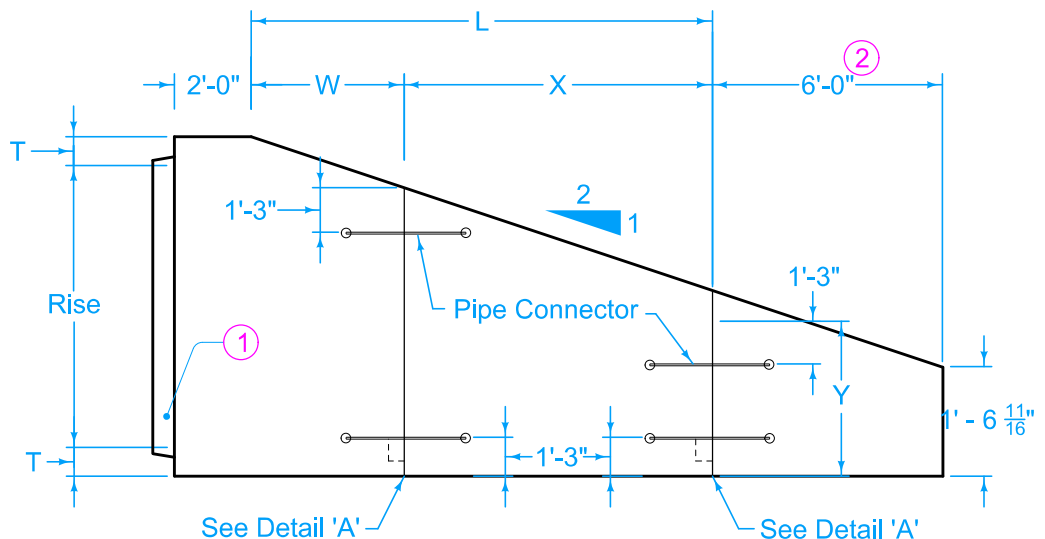

ELEVATION

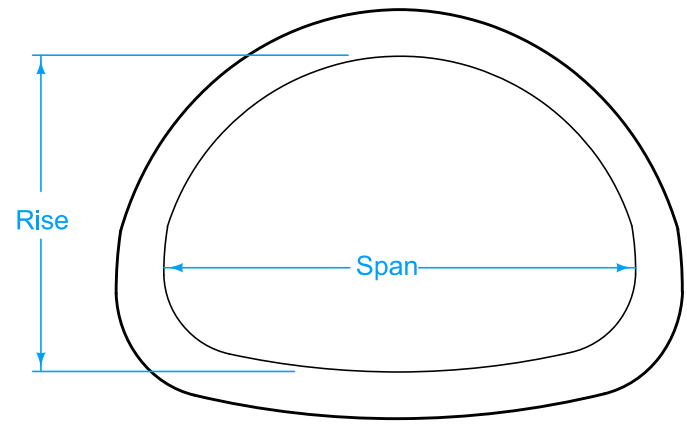

END

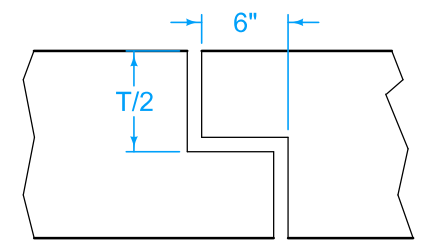

DETAIL 'A'

NOMINAL DIMENSIONS SPAN X RISE Inches	EQUIVALENT DIAMETER Inches	SPAN Inches	RISE Inches	APPROXIMATE DIMENSIONS Inches					
				T	L	W	X	Y	Z
115 X 72	90	115	72	8 1/2	102 1/4	72	30 1/4	37 7/8	48
122 X 78	96	122	77 1/2	9	112 1/2	72	40 1/2	39	54
138 X 88	108	138	87 1/8	10	129 1/2	48	81 1/2	42 3/8	66
154 X 97	120	154	96 7/8	11	144	48	96	46 7/8	78
169 X 107	132 ②	168 3/4	106 1/2	10	144	48	96	54 5/8	90

ARCH PIPE (MULTI-SECTION APRON)

 STANDARD ROAD PLAN	REVISION	
	2	10-17-23
	DR-202	
SHEET 2 of 3		

REVISIONS: Added note about shape and dimensions.

Shawn Miller
APPROVED BY DESIGN METHODS ENGINEER

**LOW CLEARANCE
CONCRETE PIPE APRONS**

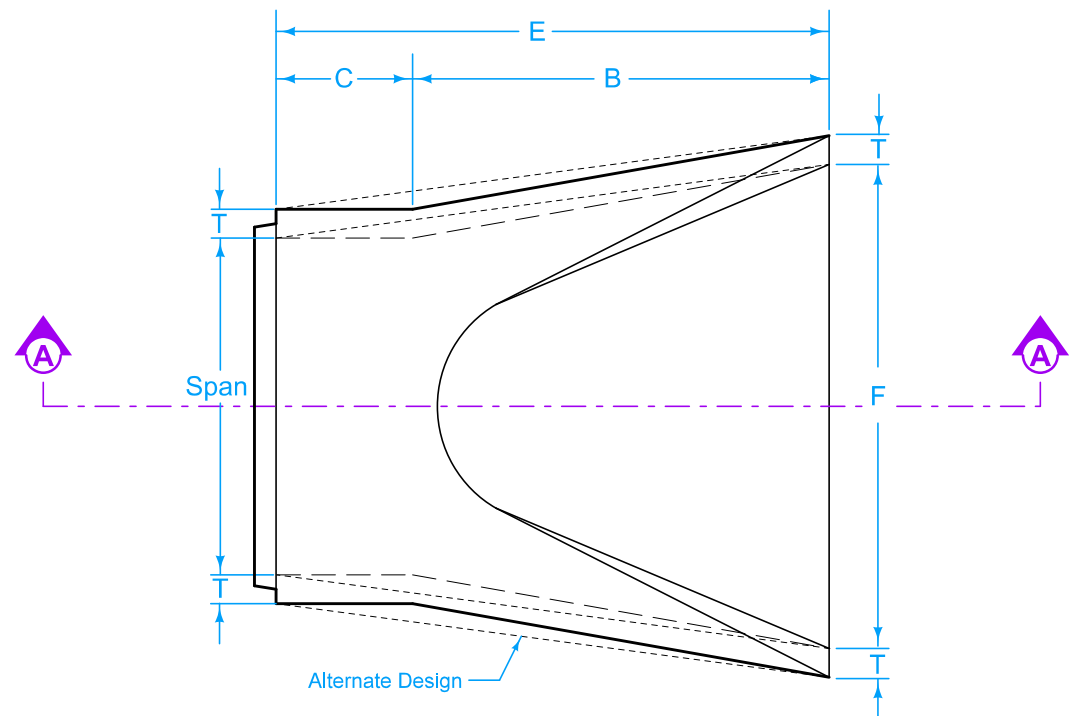

PLAN

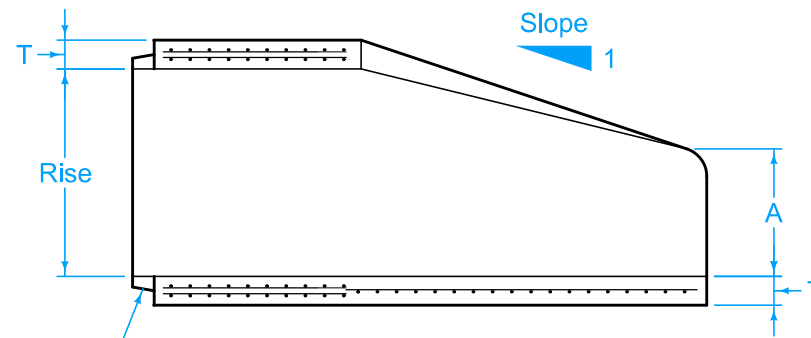

SECTION A-A

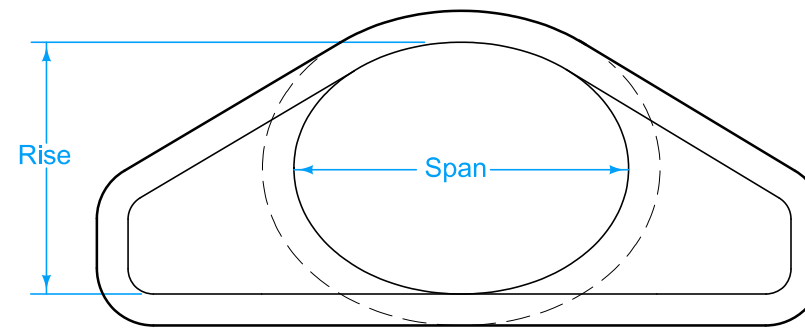

END

Comply with AASHTO M 207 for Apron Reinforcement.

Dimension "E" shown is minimum and is considered the design length. Appropriately adjust for any difference between the actual length of concrete apron installed and the length indicated hereon for the length of concrete culvert pipe furnished.

Install connected pipe joints as shown on DR-121.

Slight variations in both shape and dimensions from those shown may be accepted if approved by the engineer.

① Tongue end on inlet end section. Groove end on outlet end section. Inlet end section shown.

EQUIVALENT DIAMETER Inches	SPAN Inches	RISE Inches	SLOPE	APPROXIMATE DIMENSIONS Inches * Maximum					
				T	A	B	C	E	F
18	23	14	3:1	2 ³ / ₄	7 ¹ / ₂	27	45	72	36 *
24	30	19	3:1	3 ¹ / ₄	8 ¹ / ₂	39	33	72	48
30	38	24	3:1	3 ³ / ₄	9 ¹ / ₂	54	18	72	60
36	45	29	2.5 to 1	4 ¹ / ₂	11 ¹ / ₈	60	24	84	72
42	53	34	2.5 to 1	5	15 ³ / ₄	60	36	96	78
48	60	38	2.5 to 1	5 ¹ / ₂	21	60	36	96	84
54	68	43	2.5 to 1	6	25 ¹ / ₂	60	36	96	90
60	76	48	2.5 to 1	6 ¹ / ₂	30	60	36	96	96
72	91	58	2.5 to 1	7 ¹ / ₂	36	63	33	96	108
90	113	72	1.6 to 1	9	36 ¹ / ₂	58	38	96	113

ELLIPTICAL PIPE

	REVISION	
	2	10-17-23
	DR-202	
SHEET 3 of 3		

REVISIONS: Added note about shape and dimensions.

Shawn Miller
APPROVED BY DESIGN METHODS ENGINEER

**LOW CLEARANCE
CONCRETE PIPE APRONS**

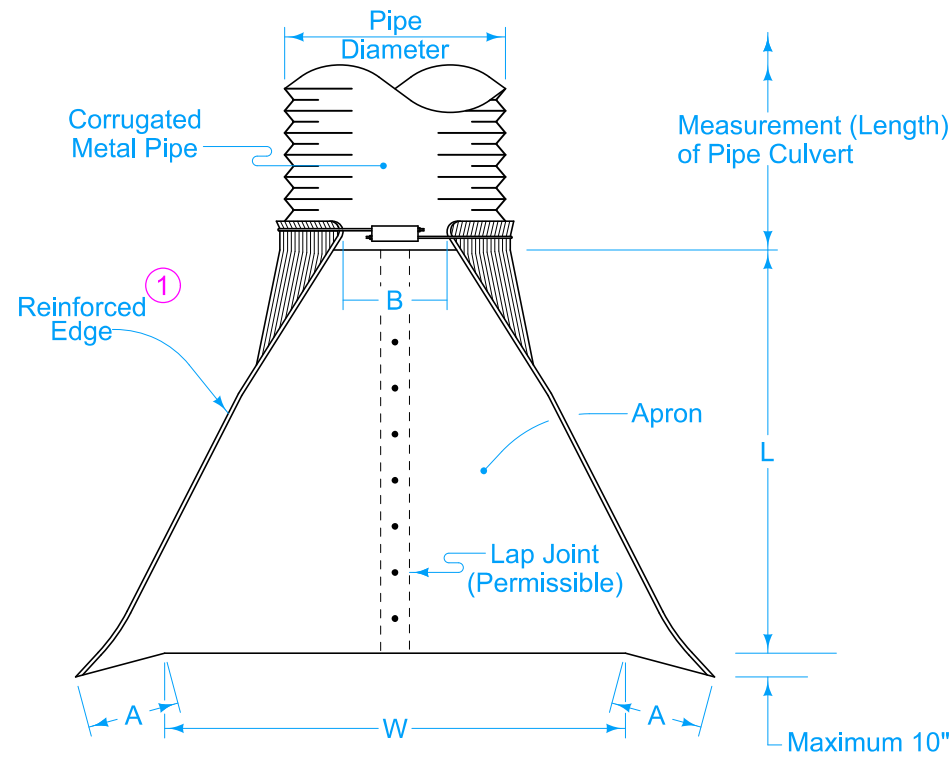

PLAN VIEW

DIMENSIONS					
PIPE DIAM.	A (±1")	B MAX.	H (±1")	L (±1½")	W (±2")
6"	4½"	1"	3"	8¾"	12"
8"	5⅞"	3"	4"	14¼"	16"
10"	7½"	6"	6"	21"	24"
12"	4¾"	6"	6"	21"	24"
15"	6"	8"	6"	26"	30"
18"	7"	9"	6"	31"	36"
21"	8¼"	11"	6"	36"	42"
24"	9½"	12"	6"	42"	48"
30"	12"	15"	7½"	52½"	60"
36"	14"	18"	9"	63"	72"
42"	16"	21"	10½"	73½"	84"
48"	18"	27"	12"	84"	90"
54"	18"	30"	12"	84"	102"
60"	18"	33"	12"	87"	114"
66"	18"	36"	12"	87"	120"
72"	18"	39"	12"	87"	126"
78"	18"	42"	12"	87"	132"
84"	18"	45"	12"	87"	138"
90"	24"	37"	11"	87"	144"
96"	25"	35"	12"	87"	150"

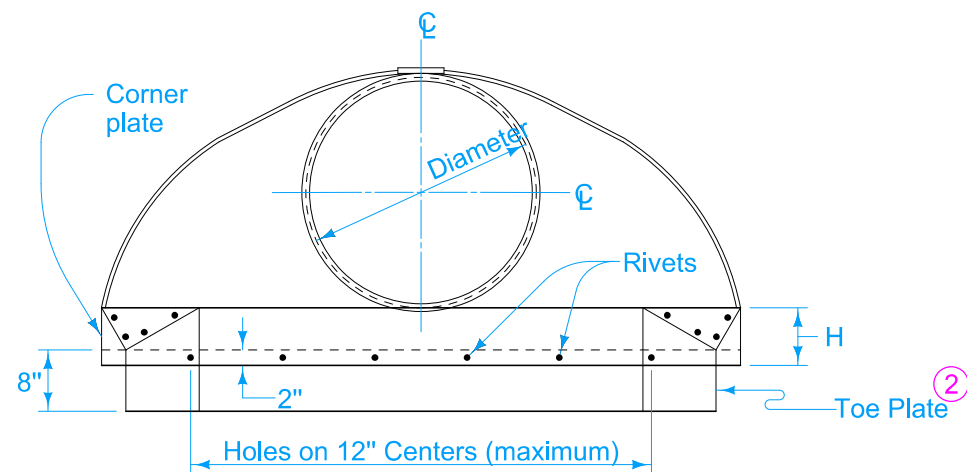

END VIEW

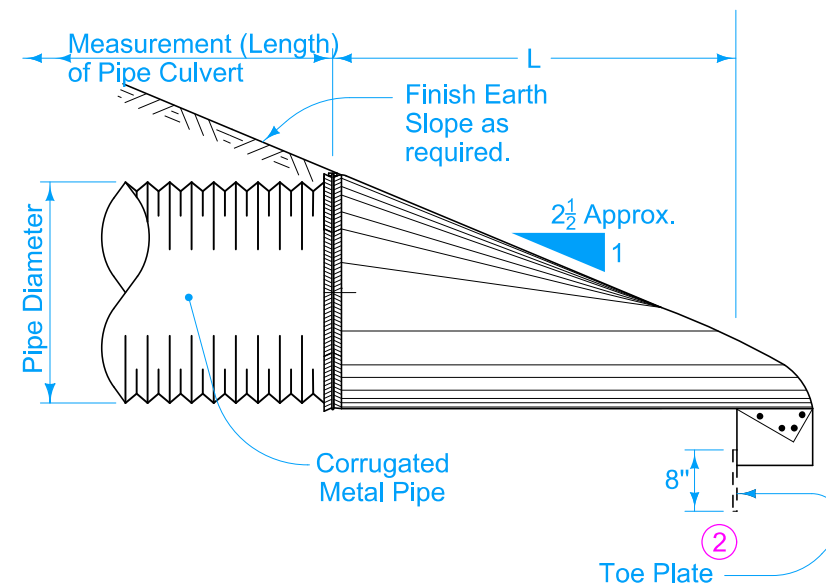

SIDE VIEW

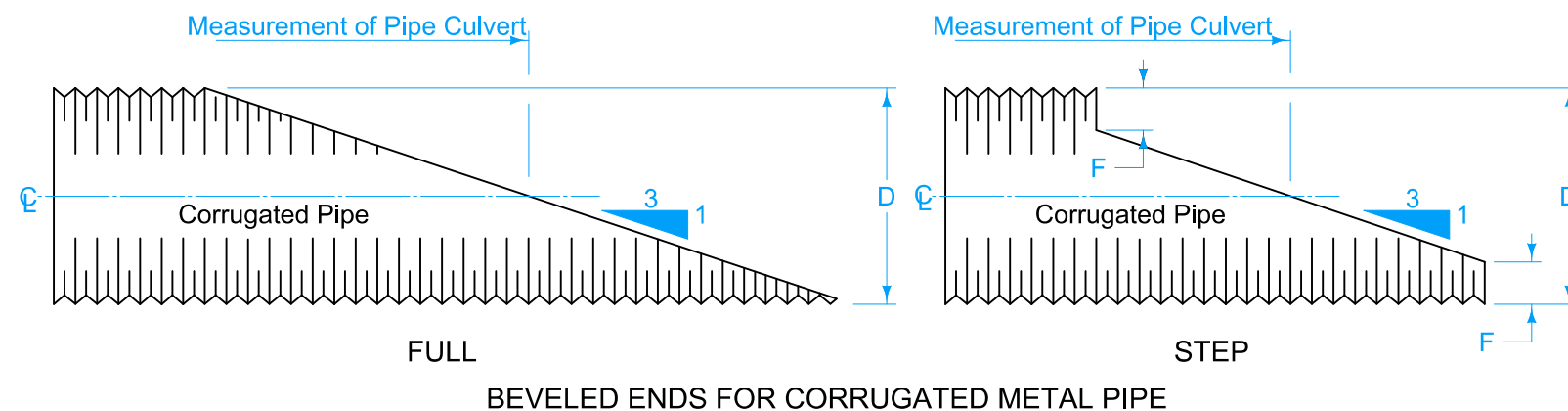

FULL STEP
BEVELED ENDS FOR CORRUGATED METAL PIPE

BEVEL 3:1	
D	F
54"	3"
60"	6"
66"	9"
72"	12"
78"	15"
84"	18"
90"	21"
96"	24"

When specifically required as part of detail project plans, ends of pipe culvert may be provided with beveled ends as shown. Either Full Bevel or Step Bevel may be used unless one type is specified. The slope of the bevel is 3:1 unless specified otherwise. Beveled ends, when required, are incidental to the price bid for the culvert.

Install aprons and hardware fabricated from galvanized steel complying with Section 4141 of the Standard Specifications. Alternate design details may be submitted to the Engineer for approval.

Aprons may be attached to culvert pipe as follows:

- A. If normal culvert is of circumferential type, use an approved bolt or clamp to fasten directly to culvert.
- B. If normal culvert is of helical corrugation type:
 - 1. Use an approved sizing ring securely fastened to inside diameter of apron to connect the culvert pipe using special dimple band connector.
 - 2. "Dimple" bands are not allowed when a positive joint is specified.

Refer to Materials I.M. 441 for approved coupling devices.

Repair, to the Engineer's satisfaction, breaks or damage to the coating that occur during handling or installation.

Price bid for "Aprons, Metal" is full compensation for fabrication and installation of the metal apron.

- ① On sizes 60 inches and larger, the reinforced edge should be supplemental with a galvanized stiffener angle attached with bolts.
- ② Install Galvanized Toe Plate (same gage metal as apron) on all aprons 24 inch diameter and larger

Possible Contract Item:
Apron, Metal

Possible Tabulations:
104-3
104-5C

<p>STANDARD ROAD PLAN</p>	REVISION	
	1	04-21-20
DR-203		
SHEET 1 of 1		
REVISIONS: Added Designer Info button.		
<p>APPROVED BY DESIGN METHODS ENGINEER</p>		
METAL PIPE APRONS AND BEVELED ENDS		

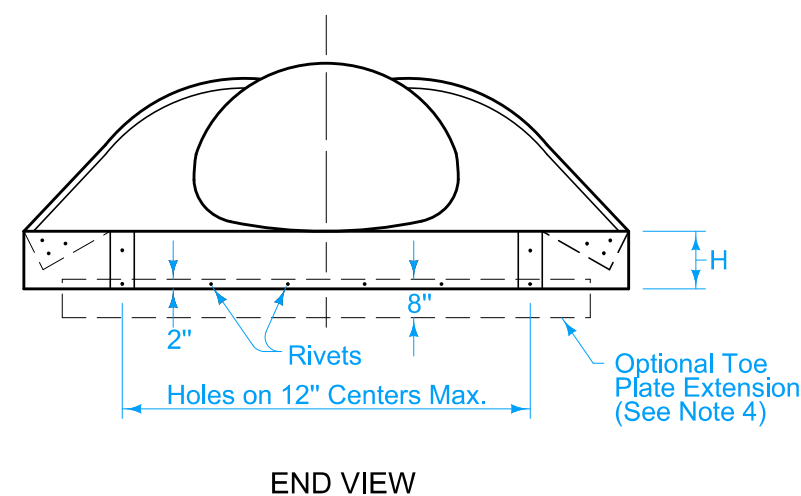
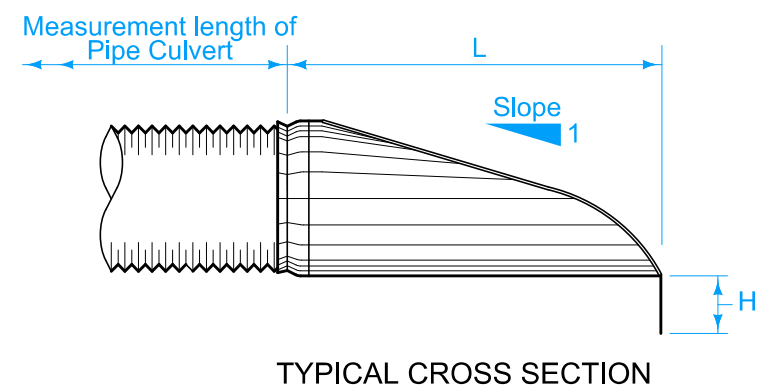
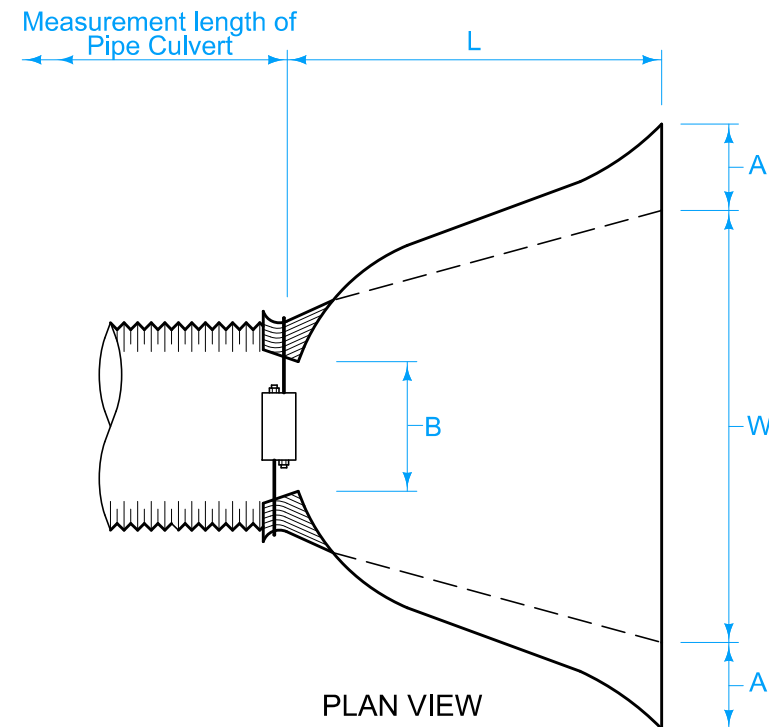

SPAN/ RISE	EQUIV. DIA.	GAGE	DIMENSIONS (In Inches)					APPROX. SLOPE
			A (±1")	B (Max.)	H (±1")	L (±1½")	W (±2")	
17"x 13"	15"	16	6½	8½-9	6	20	30	2½
21"x 15"	18"	16	7½	11	6	24	36	2½
24"x 18"	21"	16	8	12	6	28	42	2½
28"x 20"	24"	16	8	16	6	32	48	2½
35"x 24"	30"	14	10	16	7	39	60	2½
42"x 29"	36"	14	12	18	7½-8	46	75	2½
49"x 33"	42"	12	13½	21	9	53	84	2½
57"x 38"	48"	12	18½	26	12	62	90	2½
64"x 43"	54"	12	18	30	12	69	102	2¼-2
71"x 47"	60"	12/10	18½	36	12	77	114	2¼-1½
77"x 52"	66"	12/10	18	36	12	77	126	2-1½
83"x 57"	72"	12/10	18	44	12	77	135±3	2-1½

Install aprons and hardware fabricated from galvanized steel complying with Section 4141 of the Standard Specifications. Alternate design details may be submitted to the Engineer for approval.

Comply with the following:

1. All 3 piece bodies are to have 12-gage sides and 10-gage center panels. Multiple panel bodies are to have lap seams which are to be tightly joined by galvanized rivets or bolts.
2. For the 77"x52" and 83"x57" sizes, the reinforced edge is to be supplemented by galvanized angles. The angles are to be attached by galvanized nuts and bolts.
3. Angle reinforcement is to be placed under the center panel seams on the 77"x52" and 83"x57" sizes.
4. Galvanized Toe plate is to be available as an accessory when specified on the order and is to be the same gage as the end section.

Aprons may be attached to culvert pipe as follows:

- A. If culvert is of circumferential corrugation, use an approved bolt or clamp to fasten apron directly to culvert.
- B. If culvert is of helical corrugation type:
 1. Use an approved sizing ring securely fastened to inside diameter of apron to connect to the culvert pipe using a special dimple band connector.
 2. "Dimple" bands are not allowed when a positive joint is specified.

Refer to Materials I.M. 441 for approved coupling devices.

Repair, to the Engineer's satisfaction, breaks or damage to the coating that occur during handling or installation.

Price bid for "Aprons, Metal, Arch" is full compension for fabrication and installation of metal arch aprons as indicated hereon.

Possible Contract Items:
Aprons, Metal, Arch

Possible Tabulations:
104-3

	REVISION	
	2	04-21-20
STANDARD ROAD PLAN		DR-204
REVISIONS: Added Designer Info button.		SHEET 1 of 1
APPROVED BY DESIGN METHODS ENGINEER		
METAL ARCH APRONS (FOR CORRUGATED METAL PIPE)		

DESIGNER INFORMATION

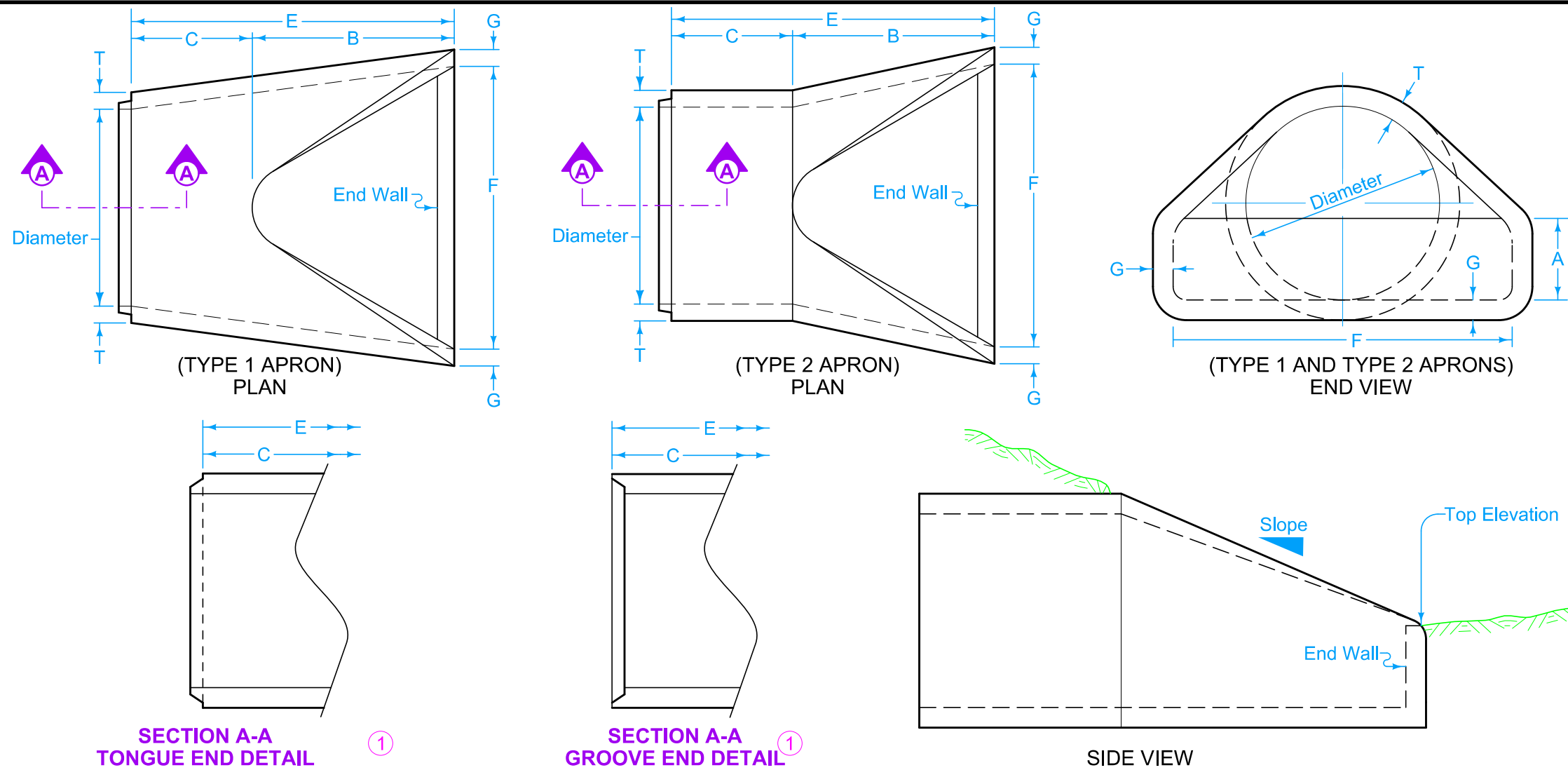

For the End Wall, match the thickness "T" and reinforcing used for the pipe apron.

Dimension "E" shown is the minimum and is considered the design length. Adjust for any difference between the actual length of concrete apron installed and the length indicated hereon within the length of concrete culvert pipe furnished.

Install connected pipe joints as shown on DR-121.

When specified in the contract documents, install pipe apron guards as shown on DR-213. Adjust connection locations to avoid conflict with end wall. Pipe apron guards are incidental to "Concrete Aprons".

Slight variations in both shape and dimensions from those shown may be accepted if approved by the engineer.

① Tongue end used on inlet end section. Groove end used on outlet end section.

TYPE 1 APRONS								* Maximum	
DIAM.	SLOPE	A	B	MINIMUM		F	G	T	
				C	E				
12"	2.4:1	4"	2'-0"	4'- $\frac{7}{8}$ "	6'- $\frac{7}{8}$ "	2'-0"	2"	2"	
15"	2.4:1	6"	2'-3"	3'-10"	6'-1"	2'-6"	2 $\frac{1}{4}$ "	2 $\frac{1}{4}$ "	
18"	2.3:1	9"	2'-3"	3'-10"	6'-1"	3'-0" *	2 $\frac{1}{2}$ "	2 $\frac{1}{2}$ "	
21"	2.4:1	9"	3'-0"	3'-1 $\frac{1}{2}$ "	6'-1 $\frac{1}{2}$ "	3'-5"	3"	3"	
24"	2.5:1	9 $\frac{1}{2}$ "	3'-7 $\frac{1}{2}$ "	2'-6"	6'-1 $\frac{1}{2}$ "	4'-0"	3"	3"	
27"	2.5:1	10 $\frac{1}{2}$ "	4'-1"	2'-0"	6'-1 $\frac{1}{2}$ "	4'-4"	3 $\frac{1}{2}$ "	3 $\frac{1}{2}$ "	
30"	2.5:1	12"	4'-6"	1'-7 $\frac{3}{4}$ "	6'-1 $\frac{3}{4}$ "	5'-0"	3 $\frac{1}{2}$ "	3 $\frac{1}{2}$ "	
36"	2.5:1	15"	5'-3"	2'-9"	8'-0"	6'-0"	4"	4"	
42"	2.5:1	21"	5'-3"	2'-9"	8'-0"	6'-6"	4 $\frac{1}{2}$ "	4 $\frac{1}{2}$ "	
48"	2.5:1	24"	6'-0"	2'-0"	8'-0"	7'-0"	5"	5"	
54"	1.8:1	27"	5'-0"	3'-0"	8'-0"	7'-6"	5 $\frac{1}{2}$ "	5 $\frac{1}{2}$ "	
60"	1.6:1	29 $\frac{1}{2}$ "	5'-0"	3'-0"	8'-0"	8'-0"	5 $\frac{1}{2}$ "	6"	
66"	1.7:1	30"	6'-0"	2'-3"	8'-3"	8'-0"	5 $\frac{1}{2}$ "	6"	
72"	1.6:1	30"	6'-6"	1'-9"	8'-3"	9'-0"	6"	7"	
78"	1.8:1	36"	7'-6"	1'-9"	9'-3"	9'-6"	6 $\frac{1}{2}$ "	7 $\frac{1}{2}$ "	
84"	1.3:1	29 $\frac{1}{2}$ "	6'-9"	2'-6 $\frac{1}{2}$ "	9'-3 $\frac{1}{2}$ "	10'-0"	6 $\frac{1}{2}$ "	8"	

TYPE 2 APRONS								* Maximum	
DIAM.	SLOPE	A	B	MINIMUM		F	G	T	
				C	E				
12"	2.4:1	4"	2'-0"	4'- $\frac{7}{8}$ "	6'- $\frac{7}{8}$ "	2'-0"	2"	2"	
15"	2.4:1	6"	2'-3"	3'-10"	6'-1"	2'-6"	2 $\frac{1}{4}$ "	2 $\frac{1}{4}$ "	
18"	2.3:1	9"	2'-3"	3'-10"	6'-1"	3'-0" *	2 $\frac{1}{2}$ "	2 $\frac{1}{2}$ "	
21"	2.4:1	9"	3'-0"	3'-1 $\frac{1}{2}$ "	6'-1 $\frac{1}{2}$ "	3'-5"	3"	3"	
24"	2.5:1	9 $\frac{1}{2}$ "	3'-7 $\frac{1}{2}$ "	2'-6"	6'-1 $\frac{1}{2}$ "	4'-0"	3"	3"	
27"	2.5:1	10 $\frac{1}{2}$ "	4'-1"	2'-0"	6'-1 $\frac{1}{2}$ "	4'-4"	3 $\frac{1}{2}$ "	3 $\frac{1}{2}$ "	
30"	2.5:1	12"	4'-6"	1'-7 $\frac{3}{4}$ "	6'-1 $\frac{3}{4}$ "	5'-0"	3 $\frac{1}{2}$ "	3 $\frac{1}{2}$ "	
36"	2.5:1	15"	5'-3"	2'-9"	8'-0"	6'-0"	4"	4"	
42"	2.5:1	21"	5'-3"	2'-9"	8'-0"	6'-6"	4 $\frac{1}{2}$ "	4 $\frac{1}{2}$ "	
48"	2.5:1	24"	6'-0"	2'-0"	8'-0"	7'-0"	5"	5"	
54"	1.9:1	24 $\frac{1}{2}$ "	5'-5"	2'-7"	8'-0"	7'-6"	5 $\frac{1}{2}$ "	5 $\frac{1}{2}$ "	
60"	1.4:1	24 $\frac{1}{2}$ "	5'-0"	3'-0"	8'-0"	8'-0"	5 $\frac{1}{2}$ "	6"	
66"	1.7:1	30"	6'-0"	2'-3"	8'-3"	8'-0"	5 $\frac{1}{2}$ "	6"	
72"	1.4:1	24"	6'-6"	1'-9"	8'-3"	9'-0"	6"	7"	
78"	1.8:1	36"	7'-6"	1'-9"	9'-3"	9'-6"	6 $\frac{1}{2}$ "	7 $\frac{1}{2}$ "	
84"	1.5:1	23 $\frac{1}{2}$ "	7'-6 $\frac{1}{2}$ "	1'-9"	9'-3 $\frac{1}{2}$ "	10'-0"	6 $\frac{1}{2}$ "	8"	

Contract Item:
Apron, Concrete

Possible Tabulation:
104-3

 STANDARD ROAD PLAN	REVISION	
	3	10-17-23
	DR-205	
SHEET 1 of 1		
REVISIONS: Added note about shape and dimensions.		
 APPROVED BY DESIGN METHODS ENGINEER		
CONCRETE APRON WITH END WALL		

DESIGNER INFORMATION

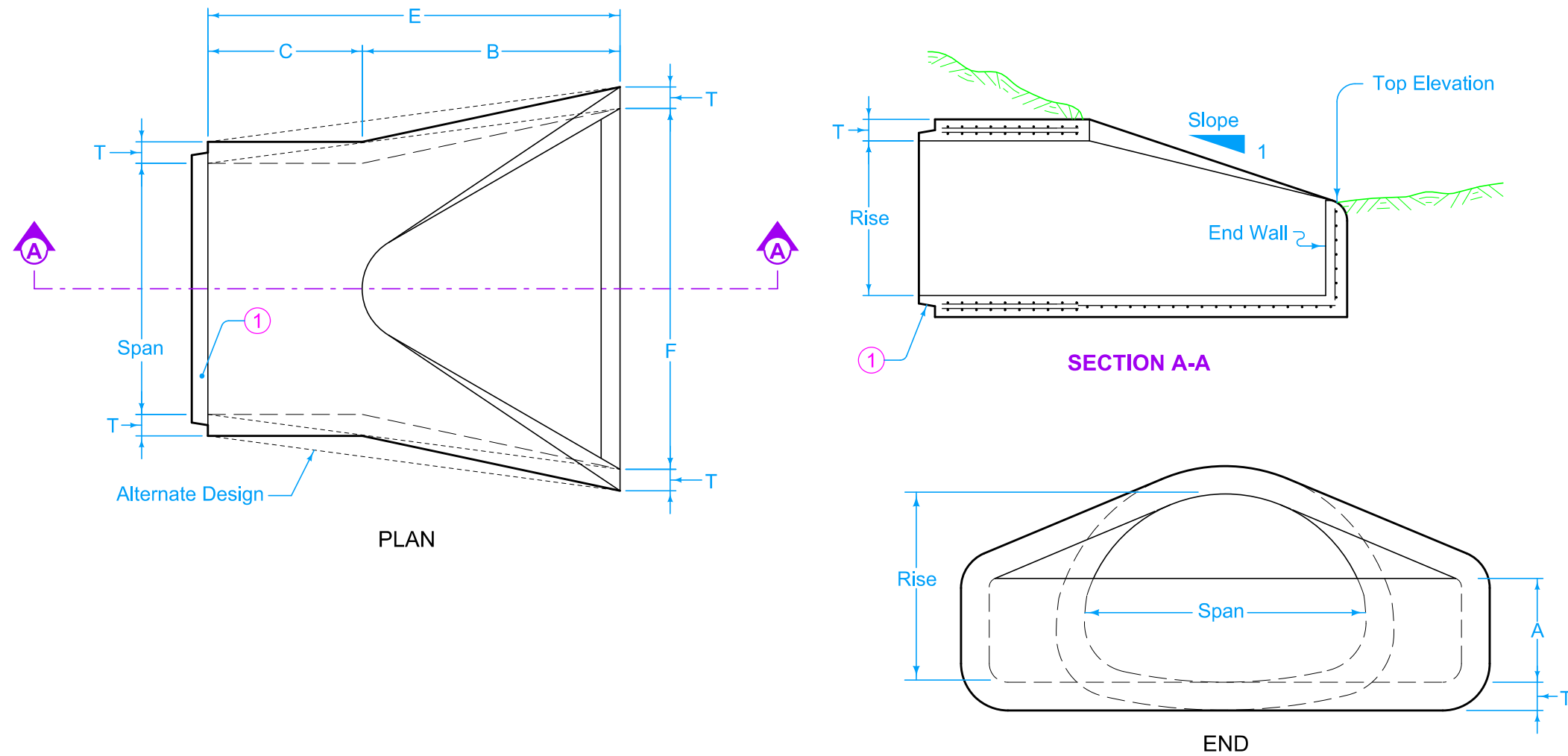

Comply with AASHTO M 206 for Apron Reinforcement.

Dimension "E" shown is minimum and is considered the design length. Appropriately adjust for any difference between the actual length of concrete apron installed and the length indicated hereon for the length of concrete culvert pipe furnished.

Install connected pipe joints as shown on DR-121.

Slight variations in both shape and dimensions from those shown may be accepted if approved by the engineer.

① Tongue end on inlet end section. Groove end on outlet end section. Inlet end section shown.

NOMINAL DIMENSIONS SPAN X RISE Inches	EQUIVALENT DIAMETER Inches	SPAN Inches	RISE Inches	SLOPE	APPROXIMATE DIMENSIONS Inches * Maximum					
					T	A	B	C	E	F
22 X 14	18	22	13 1/2	3:1	2 1/2	7	27	45	72	36 *
29 X 18	24	28 1/2	18	3:1	3	8 1/2	39	33	72	48
37 X 23	30	36 1/4	22 1/2	3:1	3 1/2	9 1/2	50	46	96	60
44 X 27	36	43 3/8	26 5/8	3:1	4	11 1/8	60	36	96	72
52 X 32	42	51 1/8	31 5/16	3:1	4 1/2	15 13/16	60	36	96	78
59 X 36	48	58 1/2	36	3:1	5	21	60	36	96	84
65 X 40	54	65	40	3:1	5 1/2	25 1/2	60	36	96	90
73 X 45	60	73	45	3:1	6	31	60	36	96	96
88 X 54	72	88	54	2:1	7	31	60	39	99	120
102 X 62	84	102	62	2:1	8	21 1/2	83	19	102	144

ARCH PIPE

Possible Contract Item:
Low Clearance Concrete Pipe Aprons

Possible Tabulations:
104-3
104-4

	REVISION	
	2	10-17-23
STANDARD ROAD PLAN		DR-206
		SHEET 1 of 2

REVISIONS: Added note about dimension and shape.

Steve Miller
APPROVED BY DESIGN METHODS ENGINEER

**LOW CLEARANCE CONCRETE
PIPE APRON WITH END WALL**

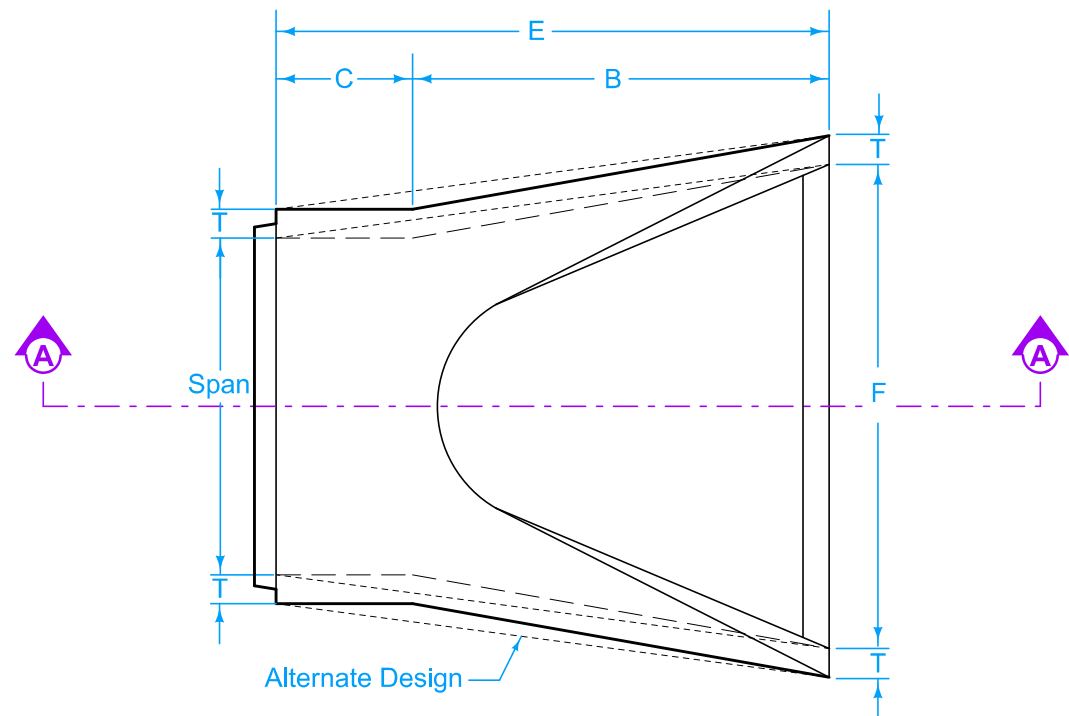

PLAN

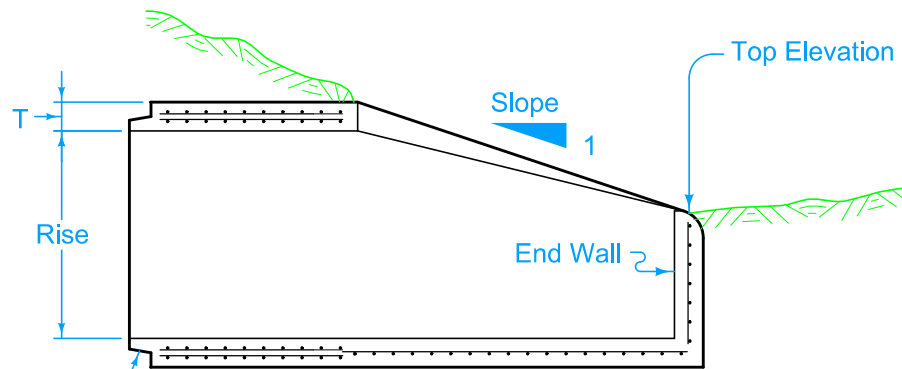

SECTION A-A

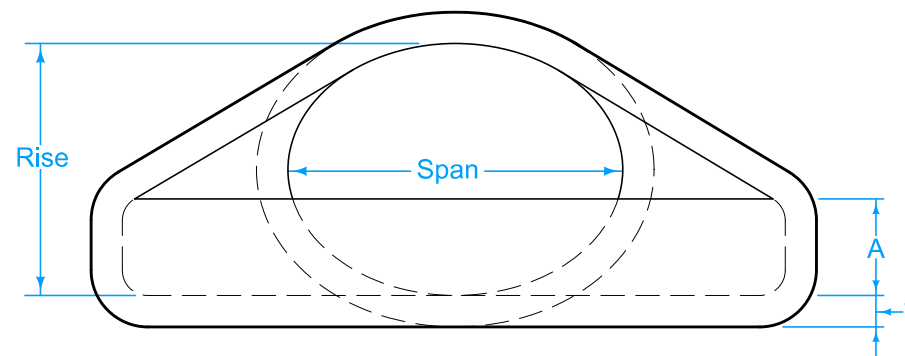

END

EQUIVALENT DIAMETER Inches	SPAN Inches	RISE Inches	SLOPE	APPROXIMATE DIMENSIONS Inches * Maximum					
				T	A	B	C	E	F
18	23	14	3:1	2 ³ / ₄	7 ¹ / ₂	27	45	72	36 *
24	30	19	3:1	3 ¹ / ₄	8 ¹ / ₂	39	33	72	48
30	38	24	3:1	3 ³ / ₄	9 ¹ / ₂	54	18	72	60
36	45	29	2.5 to 1	4 ¹ / ₂	11 ¹ / ₈	60	24	84	72
42	53	34	2.5 to 1	5	15 ³ / ₄	60	36	96	78
48	60	38	2.5 to 1	5 ¹ / ₂	21	60	36	96	84
54	68	43	2.5 to 1	6	25 ¹ / ₂	60	36	96	90
60	76	48	2.5 to 1	6 ¹ / ₂	30	60	36	96	96
72	91	58	2.5 to 1	7 ¹ / ₂	36	63	33	96	108
90	113	72	1.6 to 1	9	36 ¹ / ₂	58	38	96	113

ELLIPTICAL PIPE

Comply with AASHTO M 207 for Apron Reinforcement.

Dimension "E" shown is minimum and is considered the design length. Appropriately adjust for any difference between the actual length of concrete apron installed and the length indicated hereon for the length of concrete culvert pipe furnished.

Install connected pipe joints as shown on DR-121.

Slight variations in both shape and dimensions from those shown may be accepted if approved by the engineer.

① Tongue end on inlet end section. Groove end on outlet end section. Inlet end section shown.

	REVISION	
	2	10-17-23
STANDARD ROAD PLAN	DR-206	
	SHEET 2 of 2	
REVISIONS: Added note about dimension and shape.		
APPROVED BY DESIGN METHODS ENGINEER		
LOW CLEARANCE CONCRETE PIPE APRON WITH END WALL		

DESIGNER INFORMATION

Install aprons and hardware fabricated from galvanized steel complying with Section 4141 of the Standard Specifications. Alternate design details may be submitted to the Engineer for approval.

Apron may be attached to culvert pipe as follows:

- A. If normal culvert is of circumferential corrugation type, use an approved bolt or clamp to fasten apron directly to apron.
- B. If normal culvert is of helical corrugation type:
 1. Use an approved sizing ring securely fastened to inside diameter of apron to connect to the culvert pipe using special dimple band connector.
 2. "Dimple" bands will not be allowed when a positive joint is specified.

Refer to Materials I.M. 441 for approved coupling devices.

Repair, to the Engineer's satisfaction, breaks or damage to the coating that occur during handling or installation.

Price bid for "Aprons, Safety Slope" is full compensation for fabrication and installation of the apron.

- ① Number of bars required will vary depending on the length of the end section.
- ② Parallel safety bars are required for pipes 30" diameter and larger. For pipe 24" diameter and smaller, parallel safety bars will be required only when specified in the project plans.

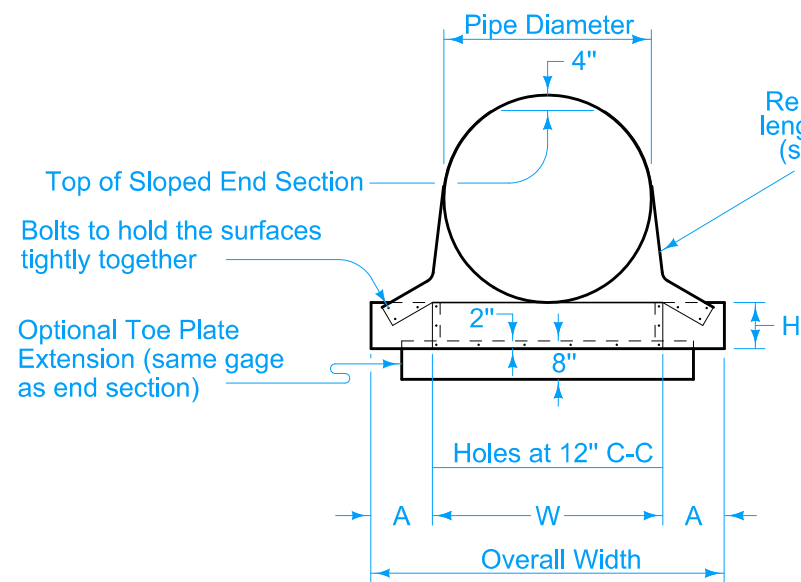

FRONT VIEW

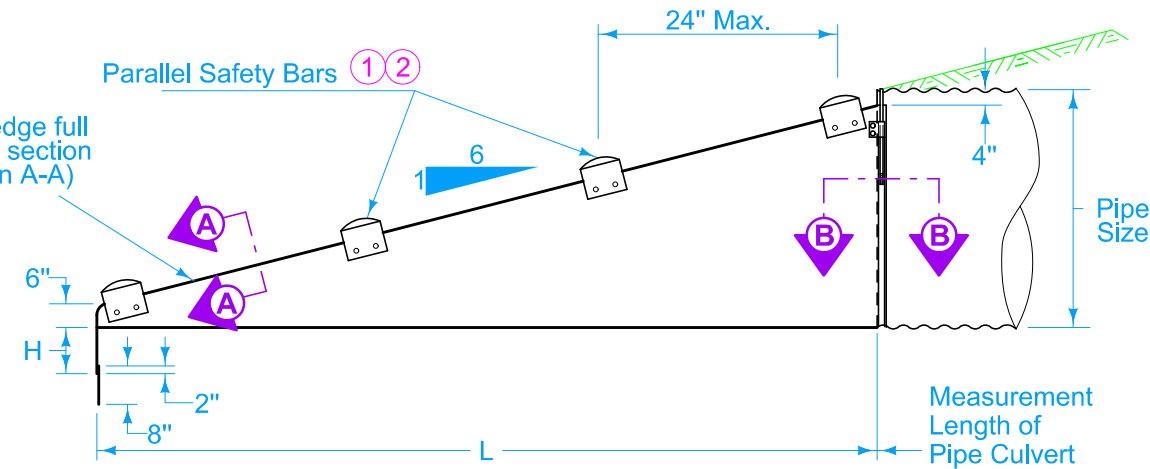

SIDE ELEVATION

METAL END SECTIONS FOR CIRCULAR PIPES

Pipe Dia. (In.)	Min. Thick.		Dimensions (Inches)				
	In.	Gage	A	H	W	Overall Width	L
15	.064	16	8	6	21	37	30
18	.064	16	8	6	24	40	48
21	.064	16	8	6	27	43	66
24	.064	16	8	6	30	46	84
30	.109	12	12	9	36	60	120
36	.109	12	12	9	42	66	156
42	.109	12	16	12	48	80	192
48	.109	12	16	12	54	86	228
54	.109	12	16	12	60	92	264
60	.109	12	16	12	66	98	300

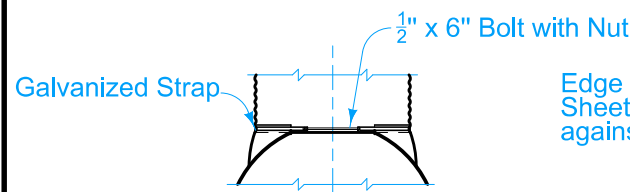

CONNECTOR (15"-24" Dia.)

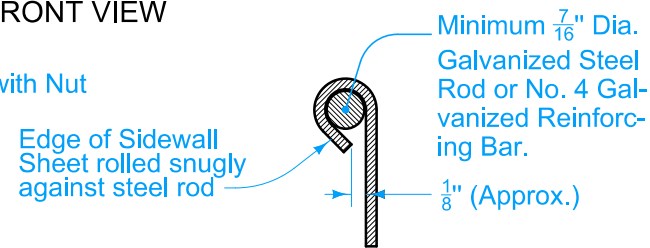

SECTION A-A

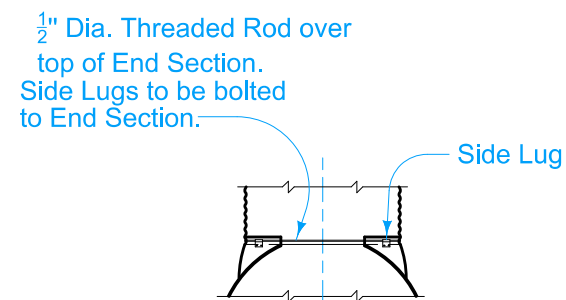

CONNECTOR (30"-60" Dia.)

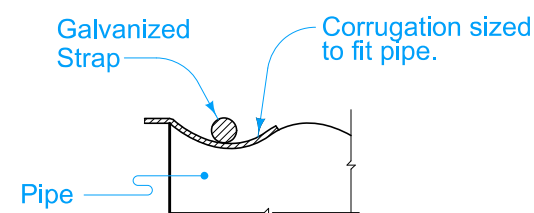

SECTION B-B

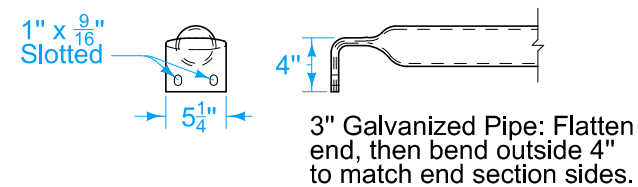

PARALLEL SAFETY BARS

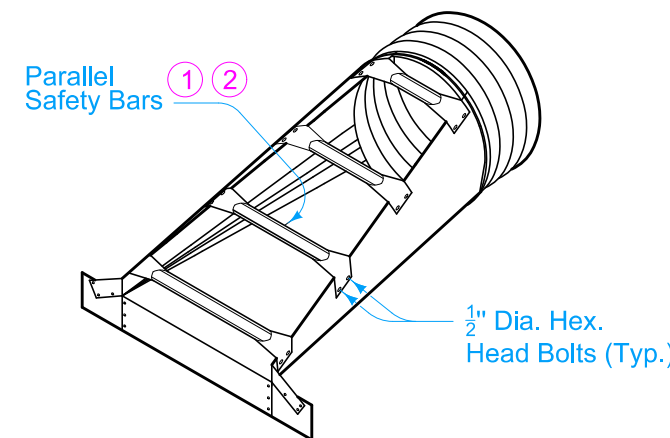

PERSPECTIVE VIEW OF APRON

Possible Contract Item:
Aprons, Safety Slope

Possible Tabulation:
104-3

	REVISION	
	1	04-21-20
STANDARD ROAD PLAN		DR-211
REVISIONS: Added Designer Info button.		SHEET 1 of 1
 APPROVED BY DESIGN METHODS ENGINEER		
METAL SAFETY SLOPE APRON 6:1 SLOPE		

DESIGNER INFORMATION

For reinforcing steel used in construction of "Beveled Pipe and Guard", use deformed bars meeting the requirements of Article 4151.03 of the Standard Specifications and hot-dip galvanized according to ASTM A123.

Use Class 'C' Concrete in the construction of Beveled Pipe and Guard.

Cut the pipe to fit the foreslope. Cut slots into the pipe for placement of the No. 8 bars. After the foreslope has been placed, fit the No. 8 bars into the slots cut in the pipe so they will be in proper position when the concrete collar is poured.

Price bid for "Beveled Pipe and Guard," each, is full compensation for furnishing all materials and constructing the Beveled Pipe and Guard.

Special Note:

A silt fence ditch check is required immediately upstream from the inlet. Refer to EC-201 for construction details.

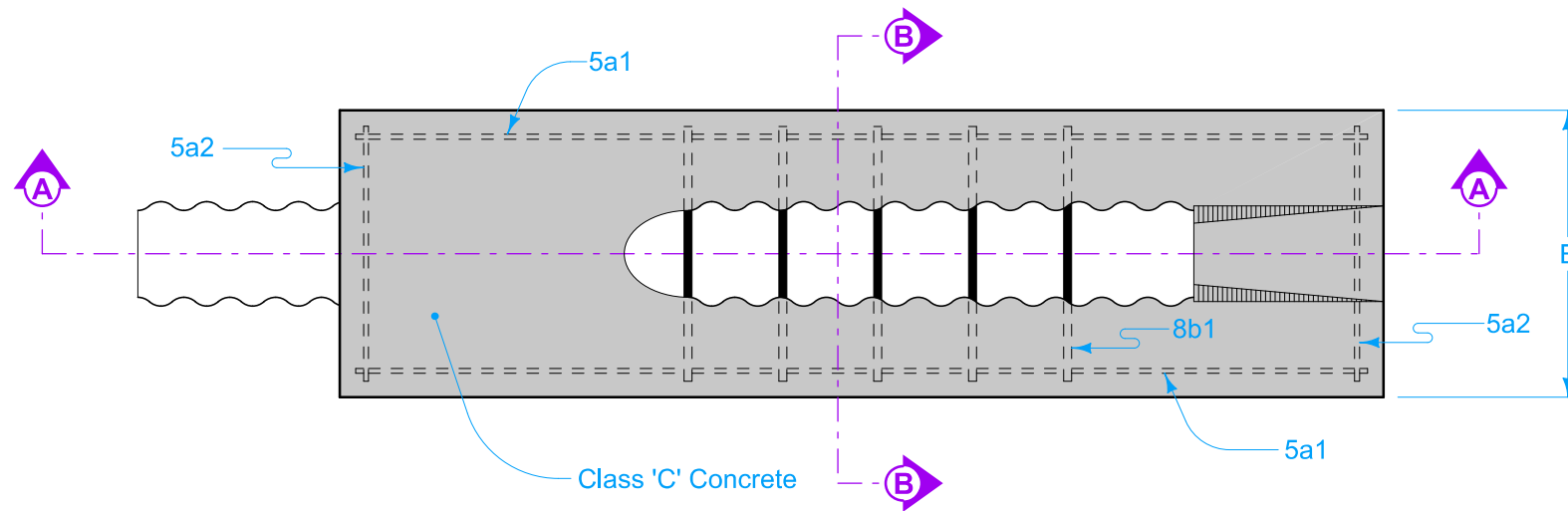

PIPE SIZE	A	B	C	D
12"	11'-0"	3'-0"	6'-0"	10'-0"
15"	13'-2"	3'-3"	8'-2"	12'-0"
18"	15'-4"	3'-6"	10'-4"	14'-0"
21"	17'-6"	3'-9"	12'-6"	16'-0"
24"	19'-8"	4'-0"	14'-8"	18'-0"

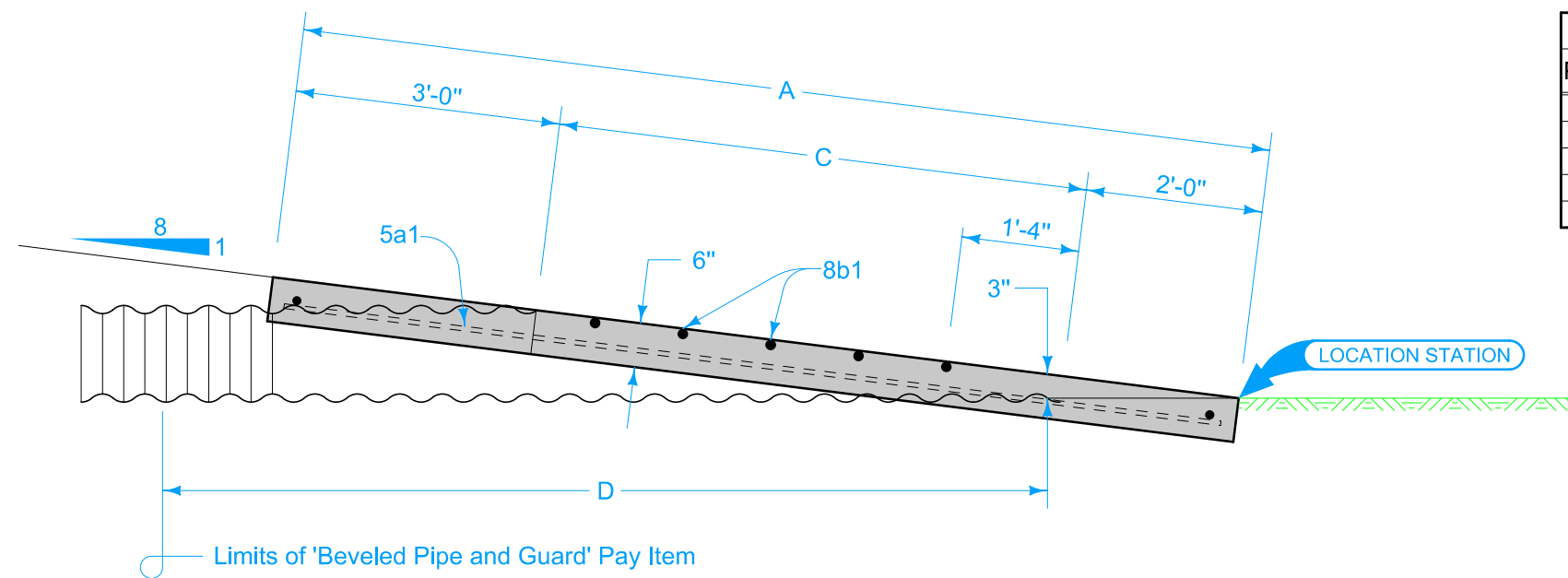

Possible Contract Item:
Beveled Pipe and Guard

Possible Tabulations:
104-3
112-8

SECTION A-A

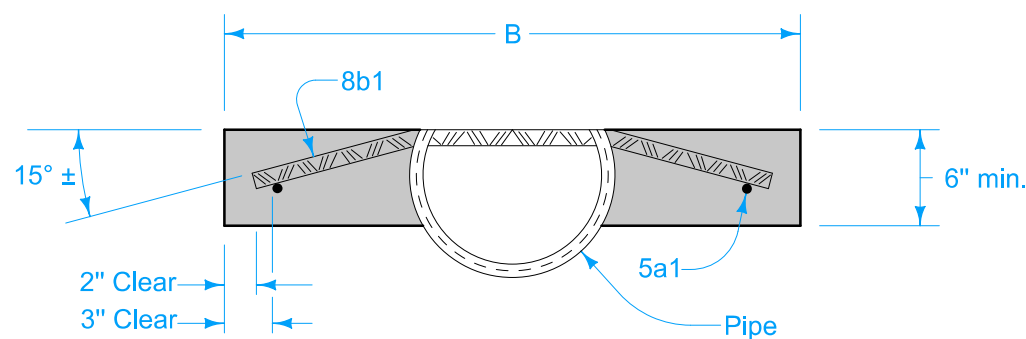

SECTION B-B

PIPE SIZE	BAR	LOCATION	SHAPE	COUNT	LENGTH	LIN. FT.	WEIGHT	TOTAL WEIGHT	SPACING
12"	5a1	Base	—	2	10'-8"	21.4	22.3	65.8	See Detail
	5a2	Base	—	2	2'-8"	5.4	5.6		See Detail
	8b1	Base	⌒	5	2'-10"	14.2	37.9		12"
15"	5a1	Base	—	2	12'-10"	25.7	26.8	90.7	See Detail
	5a2	Base	—	2	2'-11"	5.9	6.2		See Detail
	8b1	Base	⌒	7	3'-1"	21.6	57.7		12"
18"	5a1	Base	—	2	15'-0"	30.0	31.3	118.1	See Detail
	5a2	Base	—	2	3'-2"	6.4	6.7		See Detail
	8b1	Base	⌒	9	3'-4"	30.0	80.1		12"
21"	5a1	Base	—	2	17'-2"	34.4	35.9	148.6	See Detail
	5a2	Base	—	2	3'-5"	6.9	7.2		See Detail
	8b1	Base	⌒	11	3'-7"	39.5	105.5		12"
24"	5a1	Base	—	2	19'-4"	38.7	40.4	181.3	See Detail
	5a2	Base	—	2	3'-8"	7.4	7.7		See Detail
	8b1	Base	⌒	13	3'-10"	49.9	133.2		12"

	REVISION	
	1	04-21-20
STANDARD ROAD PLAN		DR-212
REVISIONS: Added Designer Info button.		SHEET 1 of 1
 APPROVED BY DESIGN METHODS ENGINEER		
BEVELED PIPE AND GUARD		

DESIGNER INFORMATION

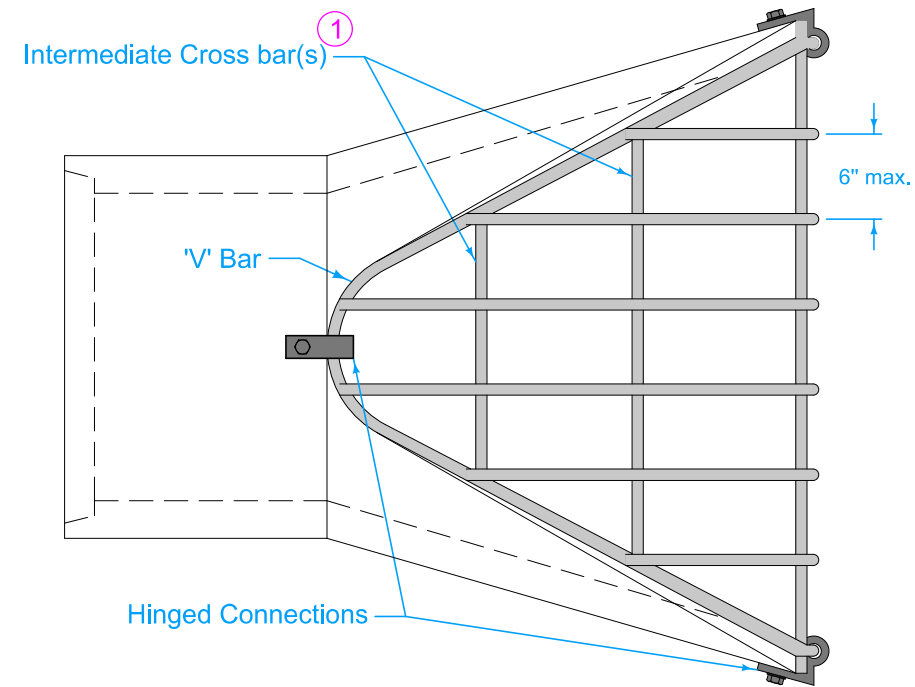

PLAN

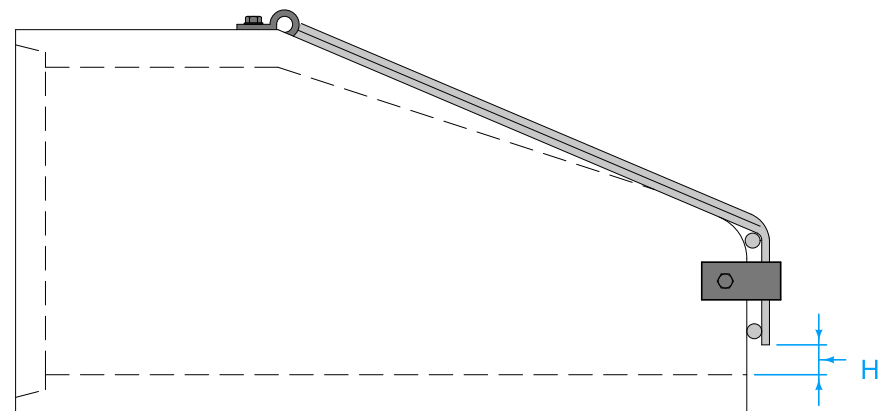

PROFILE

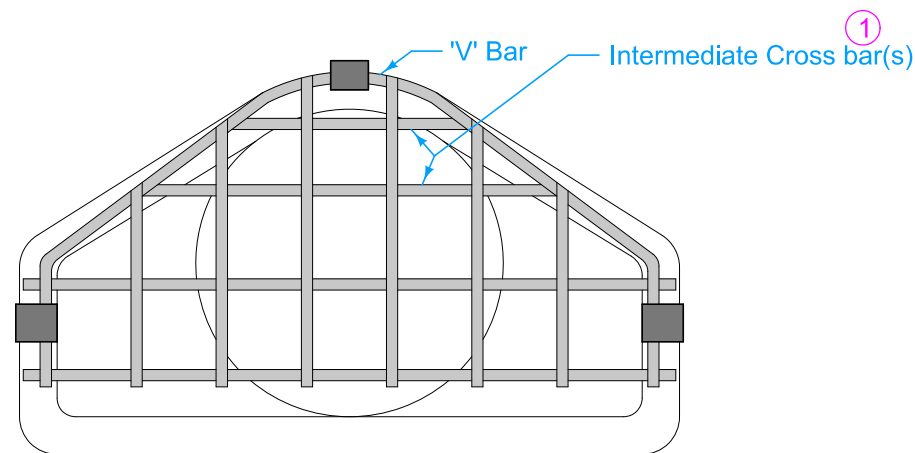

FRONT (Round Shown)

Provide guard dimensions to fit with Type of apron provided (DR-201, DR-202, DR-205, or DR-206). 'V' Bar is to completely rest on apron.

Use Grade 40, Grade 60 or merchant quality, smoothed or deformed steel bars in construction of the guard. Comply with fabrication requirements of Section 2404 of the Standard Specifications.

Hot-dip galvanize the completed apron guard according to ASTM A123.

Use bolts, nuts, washers, and fasteners complying with Article 4153.06 of the Standard Specifications.

- ① All guards are to have at least one intermediate cross bar. If pipe size is 60 inches or greater, use two intermediate cross bars equally spaced.

ROUND		ARCH		ELLIPTICAL	
PIPE SIZE	H	PIPE SIZE	H	PIPE SIZE	H
12"	2½"	22" x 14" to 29" x 18"	4"	23" x 14" to 30" x 19"	4"
15"	3"	37" x 23" to 44" x 27"	5"	38" x 24" to 45" x 29"	5"
18" - 24"	4"	52" x 32" to 65" x 40"	6"	53" x 34" to 68" x 43"	6"
27" - 36"	5"	73" x 45" to 88" x 54"	7"	76" x 48" to 91" x 58"	7"
42" - 54"	6"				
60" - 72"	7"				
78" - 90"	8"				

BAR SIZES				
	PIPE SIZE	HOLE DIA. REQ'D.	BOLT DIA.	BAR SIZE
ROUND	12" - 24"	¾"	5/8"	¾"
	27" - 48"	7/8"	¾"	1"
	54" - 90"	1 1/8"	1"	1 1/4"
ARCH	up to 29" x 18"	¾"	5/8"	¾"
	37" x 23" to 59" x 36"	7/8"	¾"	1"
	65" x 40" to 88" x 54"	1 1/8"	1"	1 1/4"
ELLIPTICAL	up to 30" x 19"	¾"	5/8"	¾"
	38" x 24" to 60" x 38"	7/8"	¾"	1"
	68" x 43" to 91" x 58"	1 1/8"	1"	1 1/4"

BOLT LENGTH = PIPE WALL THICKNESS + 2 1/2"

Possible Tabulation:
104-3

	REVISION	
	3	10-18-22
STANDARD ROAD PLAN		DR-213
REVISIONS: Modified note about grade of steel.		SHEET 1 of 1

APPROVED BY DESIGN METHODS ENGINEER

PIPE APRON GUARD

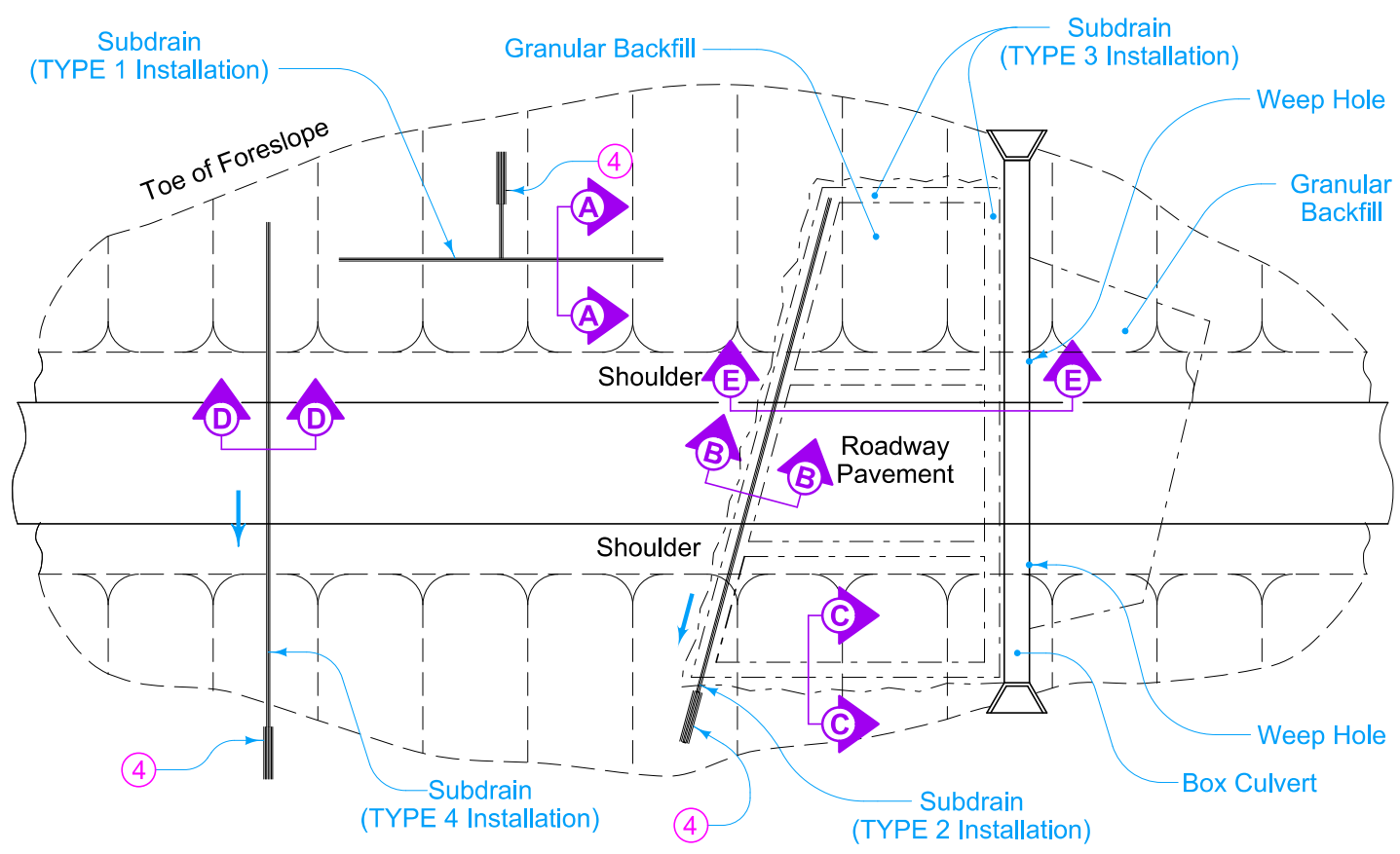

PLAN VIEW OF TYPICAL STANDARD SUBDRAIN INSTALLATIONS

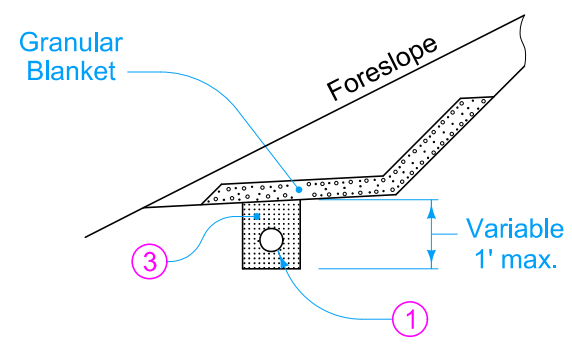

TYPE 1 INSTALLATION BENCH DRAIN SECTION A-A

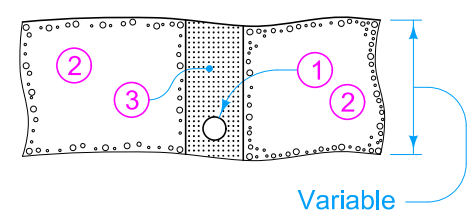

TYPE 2 INSTALLATION SUBDRAIN SECTION B-B

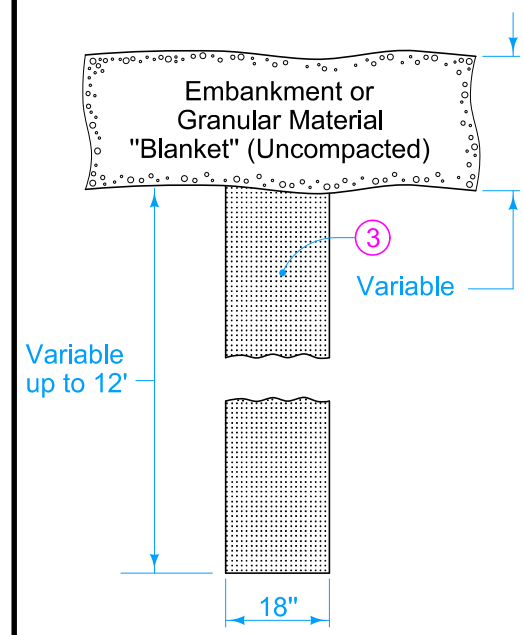

TYPE 3 INSTALLATION TRENCH DRAIN SECTION C-C

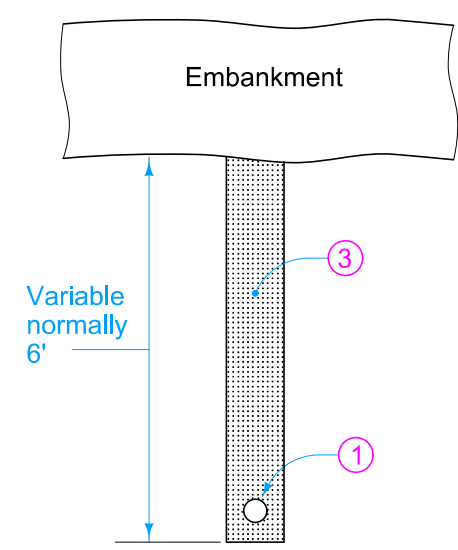

TYPE 4 INSTALLATION SUBDRAIN SECTION D-D

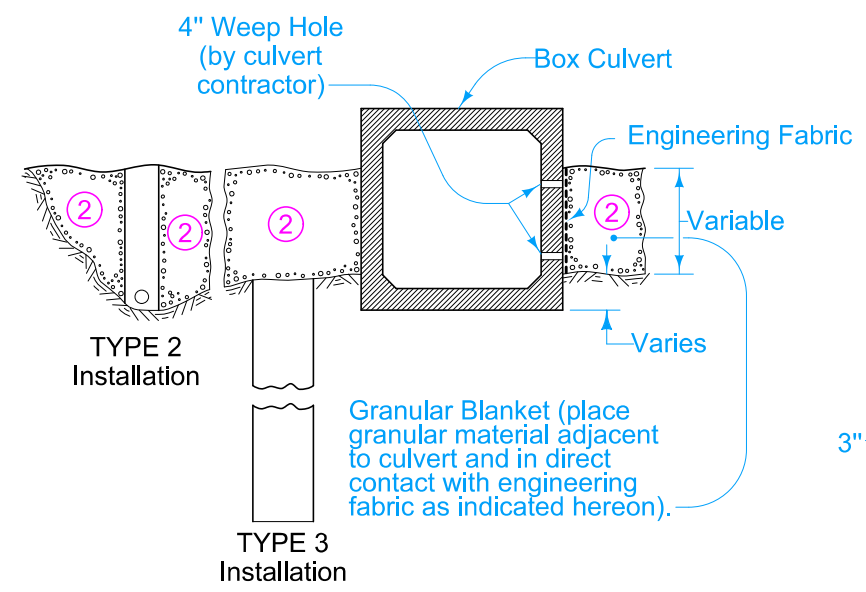

SECTION E-E SUBSOIL DRAINAGE

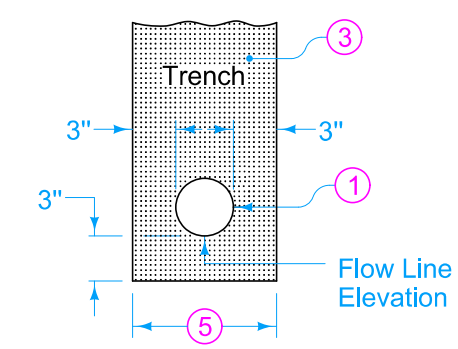

TUBING PLACEMENT DETAIL ALL TYPES

For specific information for individual locations, refer to the detail project plans, soils survey sheets, and tabulations of subdrains.

Dispose of material excavated from trenches for subdrain as directed by the Engineer. No extra compensation will be made for such disposal.

Cap blind ends of subdrains with a metal cap or by other methods approved by the Engineer. Install all perforated pipe with the perforations centered on flowline of the bottom side of the subdrain.

Place Granular Material for Blankets as indicated on the plans.

- ① Perforated Subdrain (Polyethylene Corrugated Tubing).
- ② Granular Material for Blanket (Uncompacted).
- ③ Porous Backfill (Uncompacted).
- ④ For Subdrain outlet construction details, see DR-305 and DR-306.
- ⑤ 10 inches for 4 inch subdrain; 12 inches for 6 inch subdrain.

- Possible Contract Items:
- Standard Subdrain
 - Trench Drain
 - Granular Material for Blanket and Subdrain
 - Subdrain Outlet (DR-305)
 - Subdrain Outlet (DR-306)

- Possible Tabulations:
- 104-5C
 - 104-6

 STANDARD ROAD PLAN	REVISION	
	2	04-19-22
DR-301		SHEET 1 of 1
REVISIONS: Added 104-6 to Possible Tabulations.		
 APPROVED BY DESIGN METHODS ENGINEER		
SUBDRAINS FOR FILL OR FOUNDATION DRAINAGE (STANDARD)		

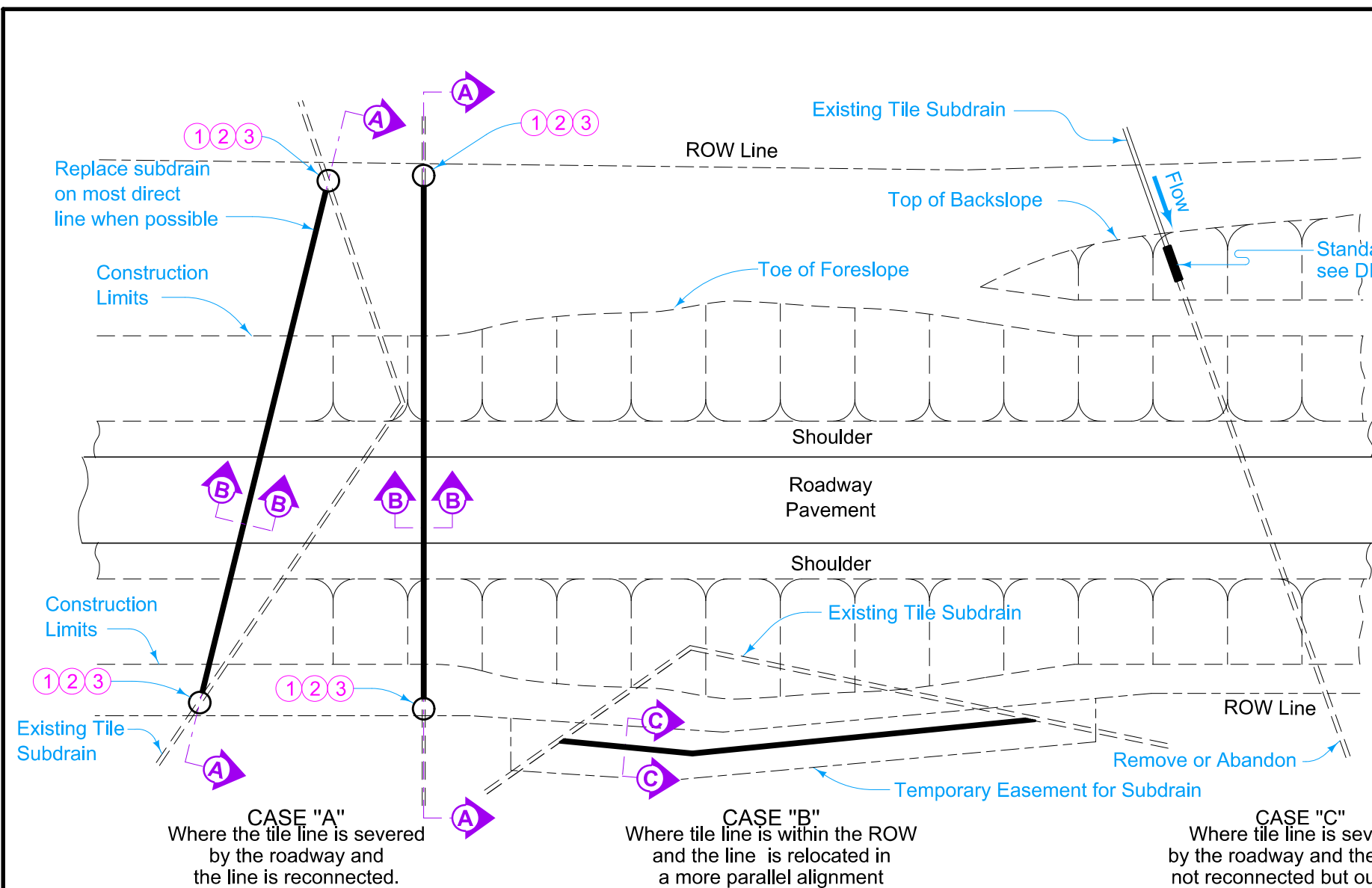

TYPICAL PLAN FOR REPLACING OR RELOCATING EXISTING FIELD TILE

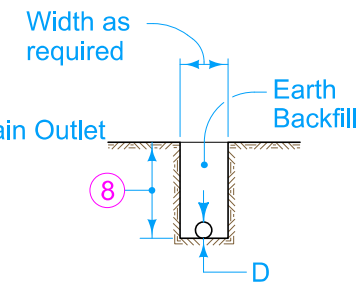

CASE "A"
SECTION B-B

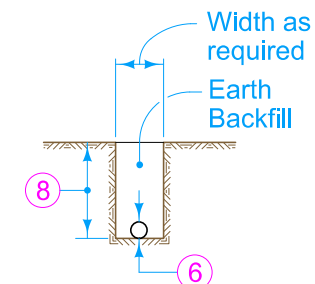

CASE "B"
SECTION C-C

Possible Contract Items:
Standard Subdrain
Subdrain Outlet

Possible Tabulation:
104-5C

When the existing tile lines are intercepted by roadway construction, replace them within the ROW limits of the project, or outlet them in a ditch or channel. Where the roadway intersects the tile line in an undesirable alignment, as shown in Case 'A', relocate the tile line to accomplish a more nearly right angle. Where the existing tile line alignment is more parallel to the roadway and within the construction limits, relocate the tile outside the ROW line, as shown in Case 'B'. In cases where new construction requires existing subdrain to outlet into the roadway ditch, as shown in Case 'C', provide the Standard Subdrain Outlet shown in DR-305.

Replace tile lines within the ROW limits according to the replacement schedule shown below. Install an inspection access at each end of replaced tile line. Replace tile lines outside the ROW limits using the same size of pipe as existing line.

REPLACEMENT SCHEDULE CASE 'A' (Pipe size in inches)		
Existing Tile Size	PROPOSED SUBDRAIN SIZE D (5)	
	Concrete Pipe	Coated CMP Pipe
4	-	10
6	-	12
8	12	15
10	15	18
12	15	21
15	18	24
18	21	30
21	24	36
24	30	36
> 24	Existing tile size + 6"	(6)

Install relocated or replacement subdrain so as to cause a minimum of disturbance to existing field tile. Connect to lines of existing tile drains in such a way as to leave the existing tile drains in a functional condition.

Cap blind ends of subdrains with a metal cap or as approved by the Engineer.

When concrete culvert pipe of 2000D (Class III) or stronger is required, furnish and install a DR-121 Type 1 connection at no additional cost to the Contracting Authority.

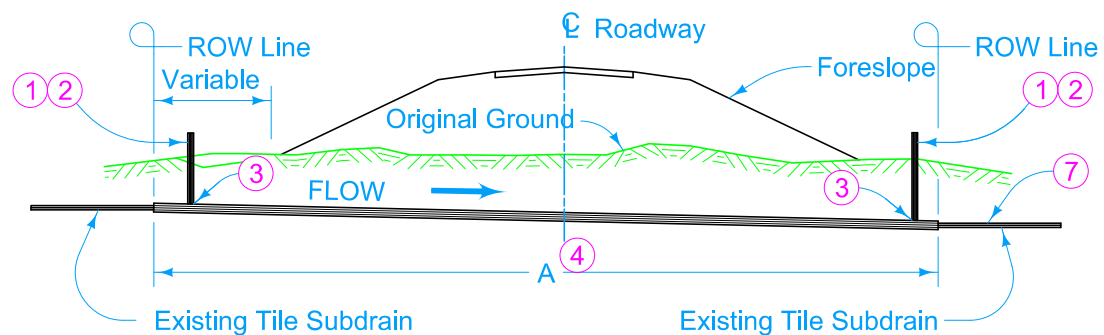

CASE "A"
SECTION A-A

- 1 4 inch diameter inspection access with cap. Minimum of 3 feet above ground. Use PVC meeting the requirements of Article 4146.03 of the Standard Specifications.
- 2 Inspection access is required to allow inspection by the upstream and downstream property owners. Perforated pipe may be used to allow ditch drainage into subdrain if approved by adjacent property owners.
- 3 A t-fitting or saddle connection is required unless an alternate connection is approved by the Engineer.
- 4 Dimension A indicates the R.O.W. limits in which replacement of tile subdrain according to the replacement schedule is required.
- 5 Replacement sizes provide equivalent capacity based on a 6 inch settlement assuming a 0.20% slope with $n=0.013$ for concrete pipe and $n=0.025$ for corrugated pipe (Manning's Formula)
- 6 Replace in kind (size and type) or with 'PE' slotted pipe, a minimum of one size larger than existing line.
- 7 When multiple drains are connected to one outlet, the outlet is to provide full capacity for all connected drain systems.
- 8 Depth as required.

	REVISION	
	2	4-18-23
STANDARD ROAD PLAN		DR-302
REVISIONS: Added note 3. Renumbered notes 4-8.		SHEET 1 of 1
 APPROVED BY DESIGN METHODS ENGINEER		
SUBDRAINS STANDARD (FARM TILE REPLACEMENT)		

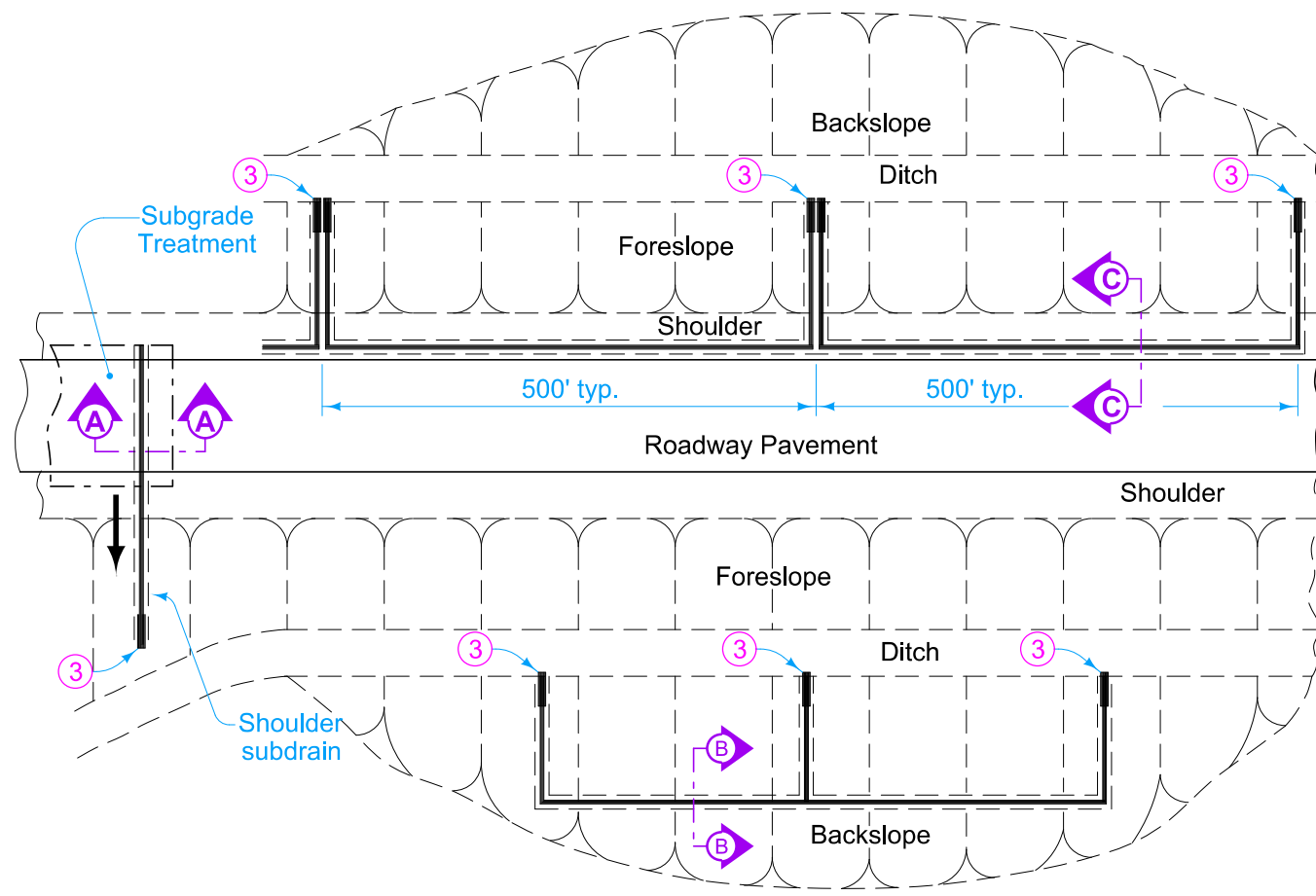

PLAN

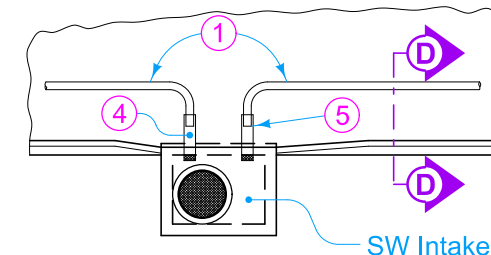

INTAKE OUTLET

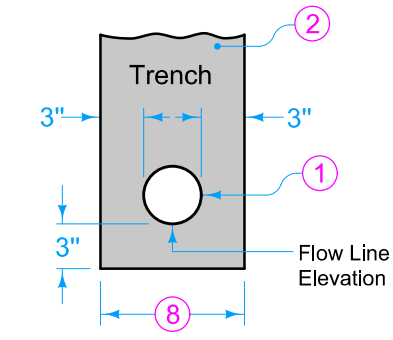

TUBING PLACEMENT ALL TYPES

- Possible Contract Items:
 Subdrain, Longitudinal, (Backslope)
 Subdrain, Longitudinal, (Shoulder)
 Subdrain Outlet (DR-303)
 Subdrain Outlet (DR-306)

Possible Tabulation:
 104-9

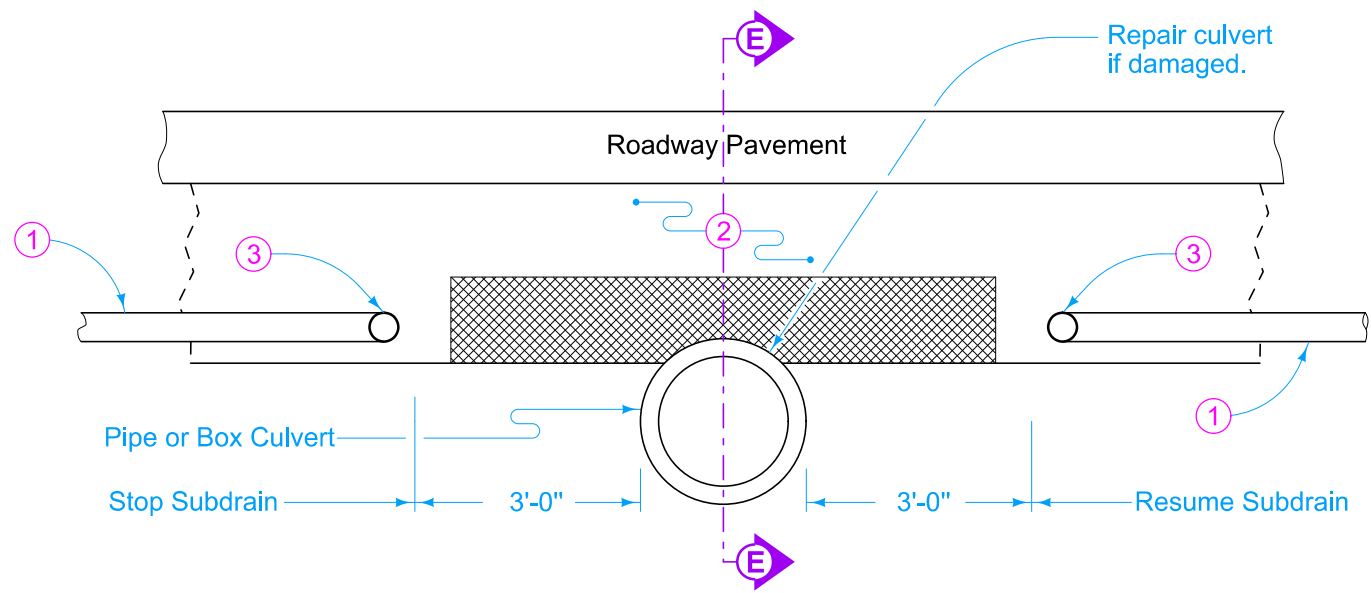

TRENCH REPAIR AT PIPE CULVERT

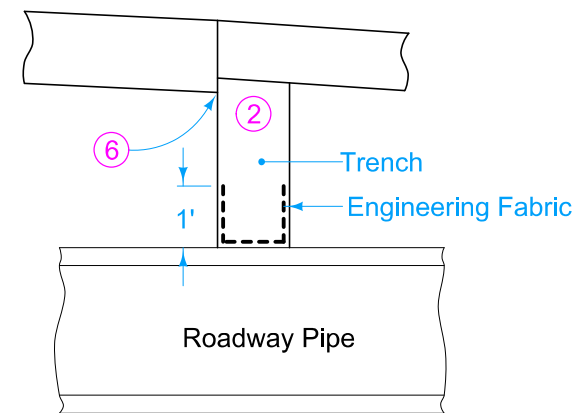

SECTION E-E

When culverts which are less than 1 foot below the trench bottom are encountered within a tabulated subdrain, stop the trench 3 feet from the culvert and resume 3 feet beyond the culvert.

On new construction projects, place the subdrain after the special backfill, if required, and prior to granular or paved shoulder material.

Except for backslope installations, if the Contractor's operations result in a trench, place and compact granular shoulder material in the trench to be level with the adjacent surface prior to opening lanes to traffic.

- 1 Perforated Subdrain (Corrugated Polyethylene Tubing).
- 2 Porous Backfill for Subdrain (compacted).
- 3 Subdrain outlets. See DR-306.
- 4 2 foot section of corrugated metal pipe of diameter 2" larger than subdrain or 2 foot section of double-walled PE or PVC pipe of the same diameter as subdrain. Pipe will be paid for as "Subdrain Outlet (DR-303)".
- 5 Connect PE or PVC outlet with an appropriate coupler. Connect CMP outlet one of two ways: (1) Inside-fit reducer coupler (1 foot minimum fit inside CMP); or (2) Insert 1 foot of the 4 inch subdrain into 6 inch CMP and fully seal entire opening with grout.
- 6 Place porous backfill in direct contact with a minimum of 2 inches of pavement and continuous to shoulder material as per note 10 or 11.
- 7 If the trench is inadvertently carried over the culvert, repair the trench as detailed on this sheet. If obstruction is 1 foot or more below trench bottom, carry subdrain line over in continuous alignment. No payment will be made for trench repair.
- 8 10 inches for 4 inch subdrain. 12 inches for 6 inch subdrain.

 STANDARD ROAD PLAN	REVISION	
	3	10-17-17
DR-303		SHEET 1 of 2

REVISIONS: References to the DR-304 have been changed to the DR-306.

Shawn Miller
 APPROVED BY DESIGN METHODS ENGINEER

**SUBDRAINS
 (LONGITUDINAL)**

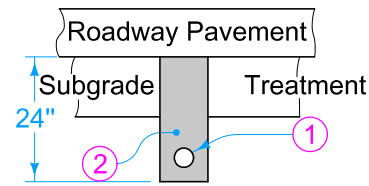

**TYPE 5 INSTALLATION
SECTION A-A
Subgrade Treatment Subdrain**

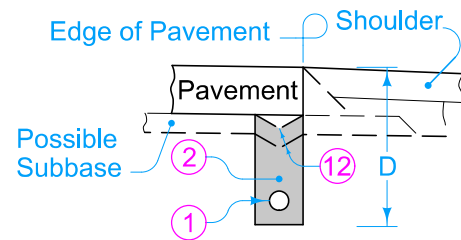

**TYPE 6 INSTALLATION
SECTION C-C
For Drain Placement Prior to
Subbase or Pavement Placement**

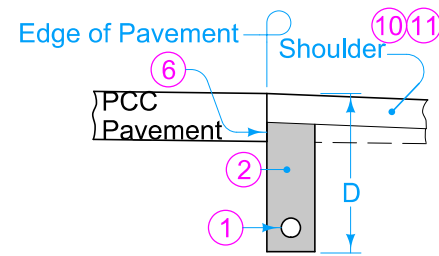

**TYPE 7A INSTALLATION
SECTION C-C**

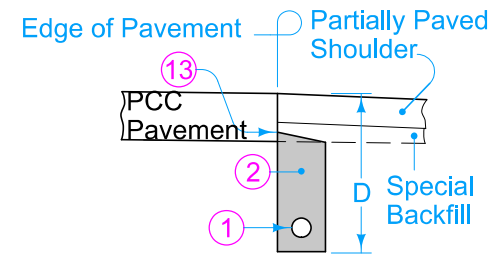

**TYPE 7B INSTALLATION
SECTION C-C**

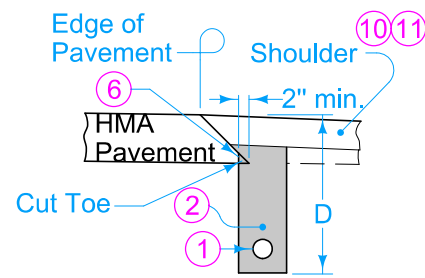

**TYPE 8A INSTALLATION
SECTION C-C**

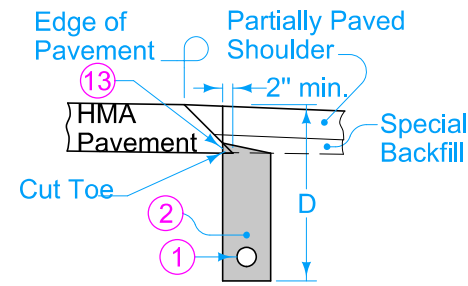

**TYPE 8B INSTALLATION
SECTION C-C**

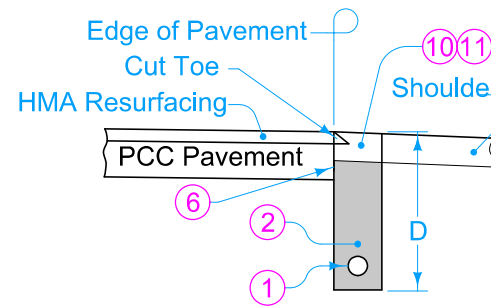

**TYPE 9 INSTALLATION
SECTION C-C
Composite Pavement
with Existing Shoulder**

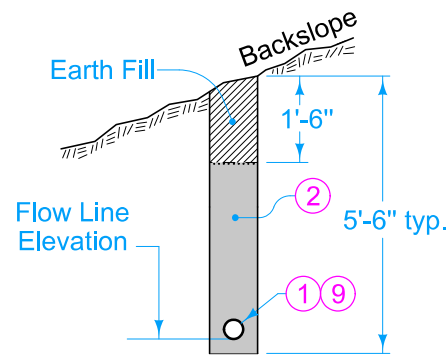

**TYPE 11 INSTALLATION
SECTION B-B
Backslope**

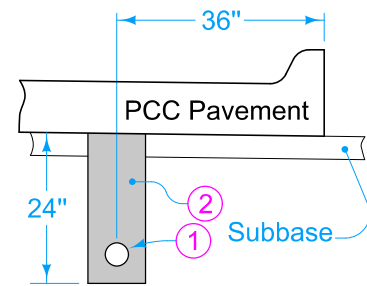

**TYPE 12 INSTALLATION
SECTION D-D**

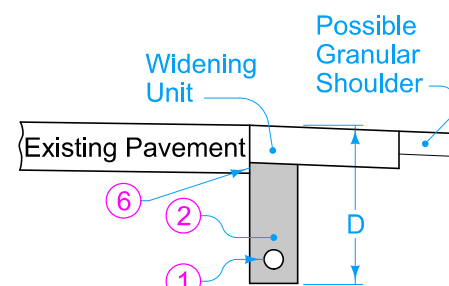

**TYPE 13 INSTALLATION
SECTION C-C
For New Widening Unit if
Thinner than Existing Pavement**

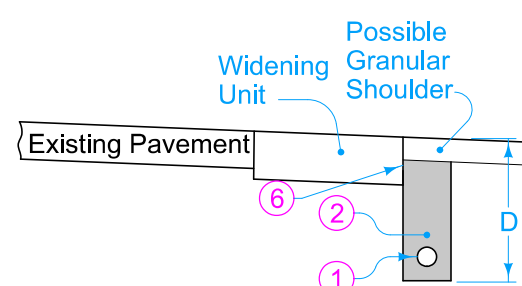

**TYPE 14 INSTALLATION
SECTION C-C
For New Widening Unit if
Thicker than Existing Pavement**

- ① Perforated Subdrain (Corrugated Polyethylene Tubing).
- ② Porous Backfill for Subdrain (compacted).
- ⑥ Place porous backfill in direct contact with a minimum of 2 inches of pavement and continuous to shoulder material as per note 11 or 12.
- ⑨ Install subdrain as cut proceeds.
- ⑩ On existing Granular or Earth Shoulders, replace with 4 inch minimum depth granular shoulder material.
- ⑪ On Paved Shoulders, refer to Section 2502 of the Standard Specifications for finishing shoulder.
- ⑫ Cut "V" notch just prior to subbase (if proposed) or pavement placement to assure uncontaminated contact.
- ⑬ Place top of subdrain trench at the bottom of pavement. Backfill trench so that a wedge of porous backfill has a minimum vertical contact of 2 inches with the pavement.

 STANDARD ROAD PLAN	REVISION	
	3	10-17-17
	DR-303 SHEET 2 of 2	
REVISIONS: References to the DR-304 have been changed to the DR-306.		
 APPROVED BY DESIGN METHODS ENGINEER		
SUBDRAINS (LONGITUDINAL)		

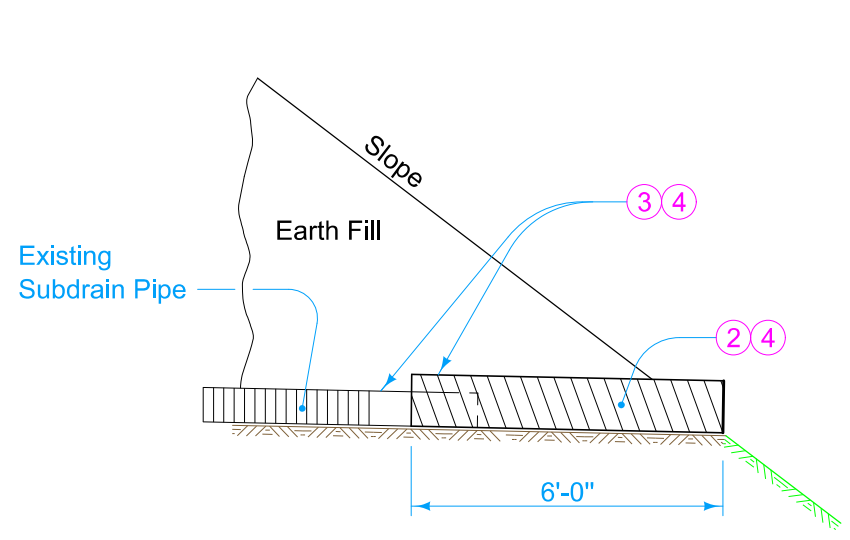

**STANDARD SUBDRAIN OUTLET
TYPE A**
For existing subdrain pipes 12" or less in diameter. ⁵

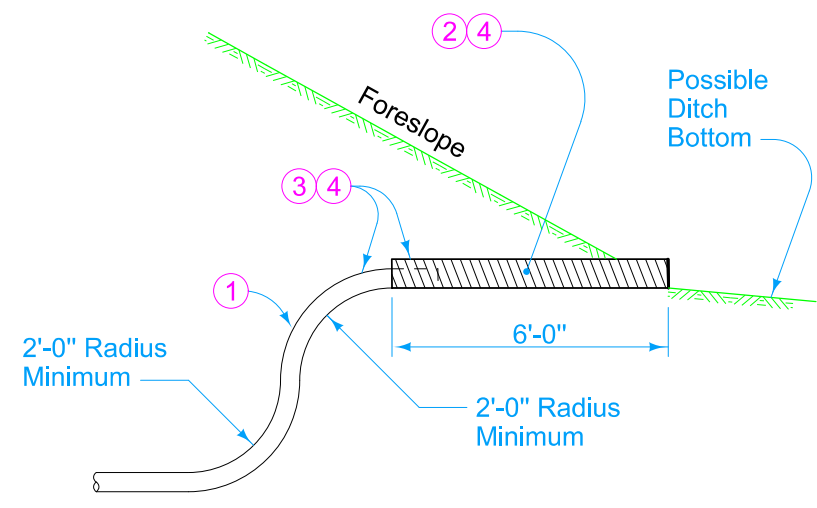

**PRESSURE RELEASE OUTLET
TYPE B**

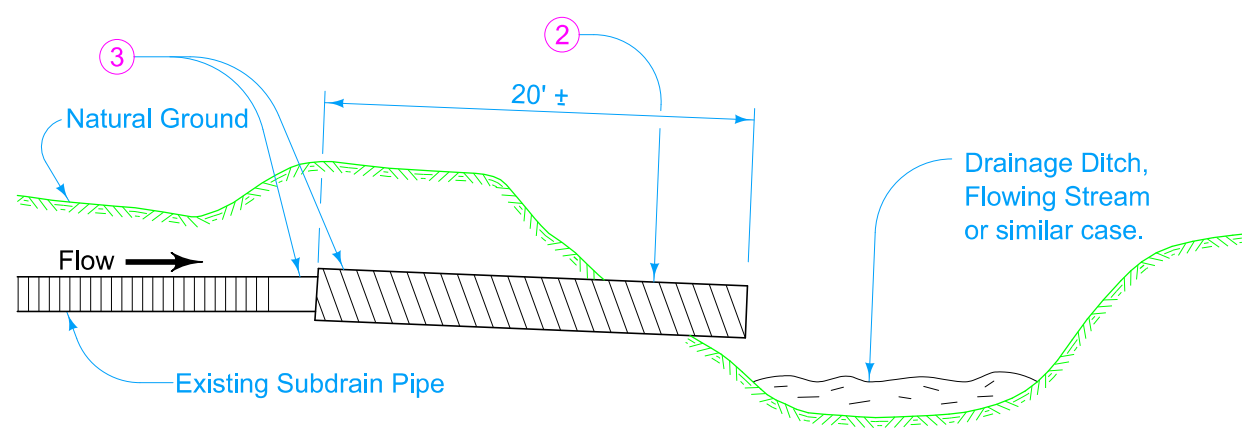

**SPECIAL OUTLET
TYPE C**

- ① Perforated Subdrain (Polyethylene Corrugated Tubing).
- ② If corrugated metal pipe is used, an outlet 2 inches larger than existing subdrain pipe is required. If double-walled PE or PVC pipe is used, an outlet pipe of the same diameter as the existing subdrain pipe may be used.
- ③ The pipes should be coupled in one of the two following ways: (1) Use an inside fit reducer coupler (coupler must be inserted a minimum of 12 inches into C.M.P.); or (2) Insert 12 inches of the existing subdrain pipe into the corrugated metal outlet pipe, then fully seal the entire opening with grout.
- ④ If a concrete headwall is used, refer to DR-306.
- ⑤ For existing subdrain pipes larger than 12 inches in diameter, use Special Outlet, Type C.

Possible Contract Item:
Subdrain Outlet (DR-305)

Possible Tabulations:
104-5C
104-6

 STANDARD ROAD PLAN	REVISION	
	2	04-19-22
	DR-305	
SHEET 1 of 1		

REVISIONS: Added 104-6 to Possible Tabulations.

Shawn Miller
APPROVED BY DESIGN METHODS ENGINEER

**SUBDRAIN OUTLETS
(STANDARD SUBDRAIN,
PRESSURE RELEASE AND SPECIAL)**

DESIGNER INFORMATION

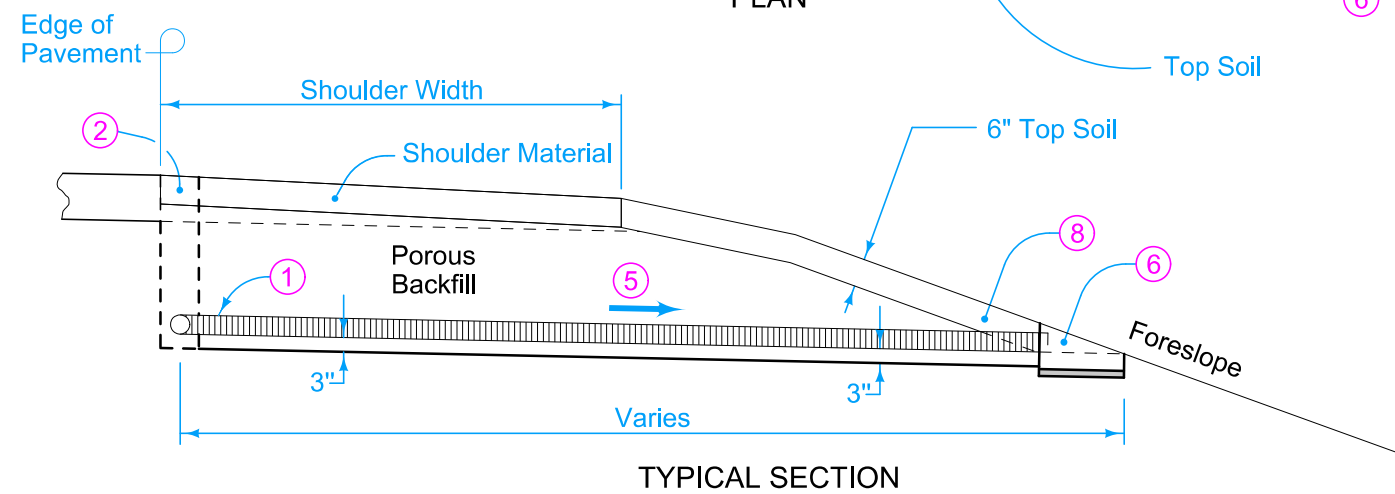
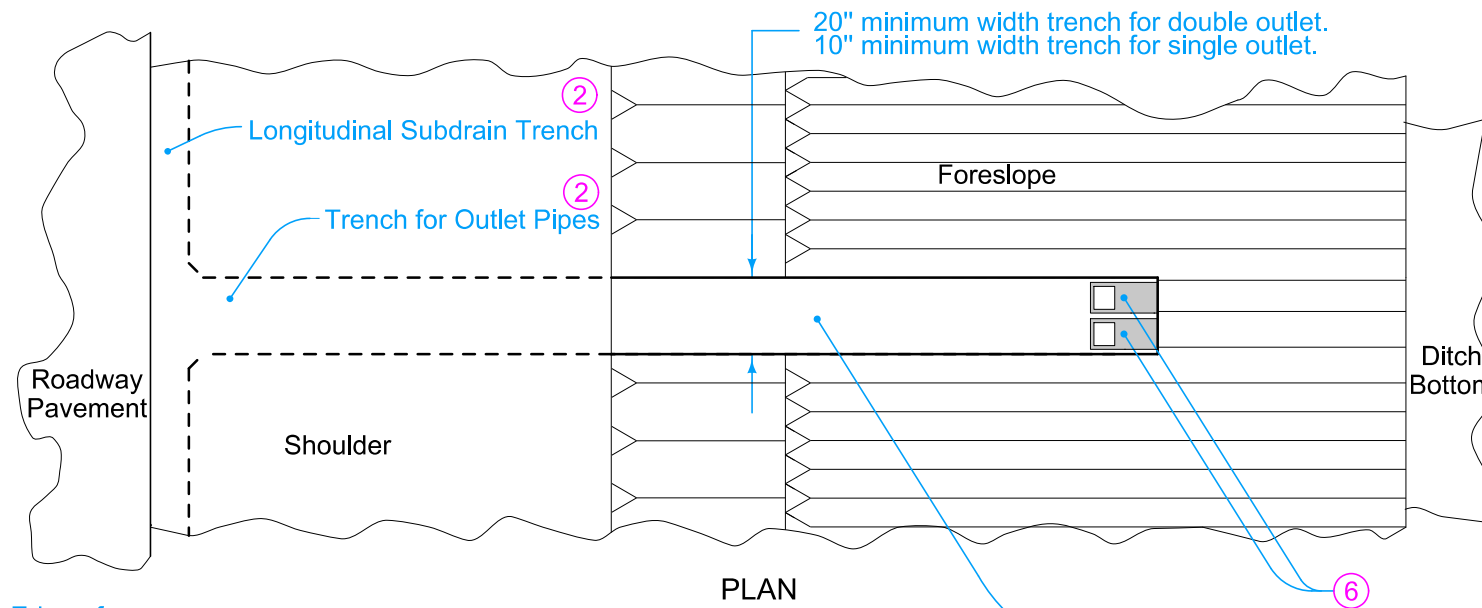

LONGITUDINAL AND TRANSVERSE OUTLETS

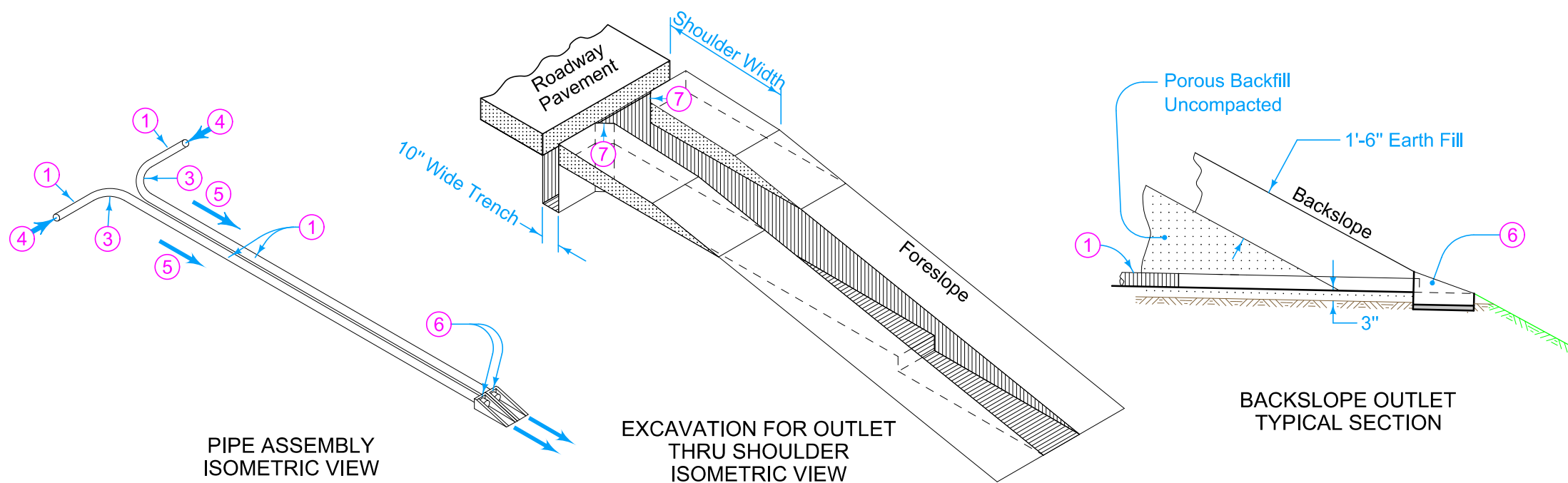

Extend subdrain 3 inches minimum (6 inches maximum) into precast subdrain headwall. Connect using one of the following methods:
 -Grouted connection using a non-shrink grout complying with Materials I.M. 491.13.
 -Gasketed connection approved by the Engineer.

Shape adjacent slope to match slope of precast subdrain headwall.

- ① Perforated Subdrain (Polyethylene Corrugated Tubing).
- ② On projects where existing shoulder material is removed, replace the shoulder material according to Article 2502.03, C of the Standard Specifications.
- ③ 'Y' or 'T' connection will not be allowed. Place subdrain on 1 foot minimum radius.
- ④ Direction of flow.
- ⑤ 6 inch minimum drop in elevation between longitudinal subdrain and outlet. 12 inch minimum drop for projects using recycled PCC subbase.
- ⑥ Precast concrete headwall.
- ⑦ Bevel the trench to provide a minimum of 3 inches of porous backfill surrounding all portions of subdrain pipe.
- ⑧ Place Top Soil over outlet and carefully compact to avoid damaging outlet pipe.

Possible Contract Item:
Subdrain Outlet, DR-306

Possible Tabulation:
104-5C
104-9

 STANDARD ROAD PLAN	REVISION	
	2	10-17-23
DR-306		SHEET 1 of 2

REVISIONS: Change from granular cap to top soil cap.

Shawn Miller
APPROVED BY DESIGN METHODS ENGINEER

PRECAST CONCRETE HEADWALL FOR SUBDRAIN OUTLETS

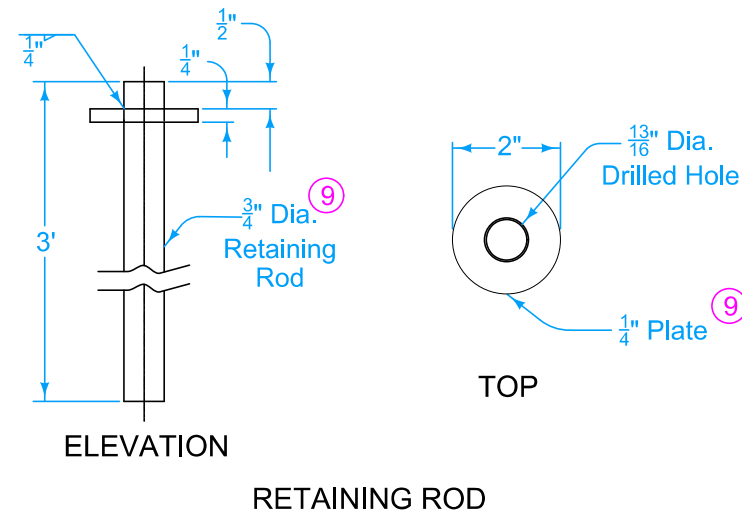
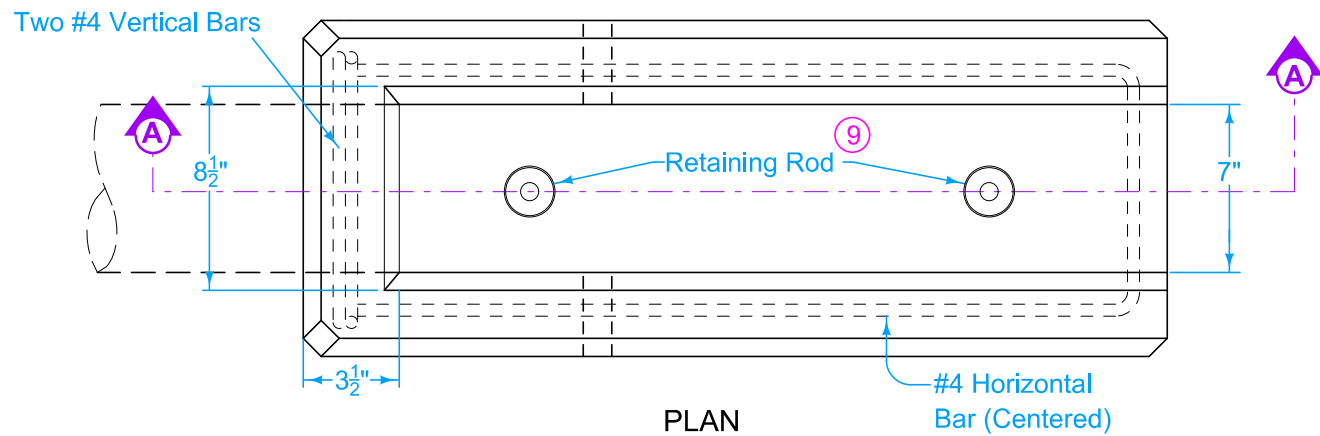

Comply with Section 2419 of the Standard Specifications.

- ⑨ ASTM A36 Steel galvanized according to ASTM A123 or ASTM F2329 after shop welding is complete.
- ⑩ After installing retaining rod, fill recess with bituminous material complying with ASTM C990 to prevent moisture infiltration.
- ⑪ Granular material complying with Section 4133 of the Standard Specifications.
- ⑫ Maximum diameter 2 inches. Fill hole with soil tight plug after placing headwall and before placing backfill.

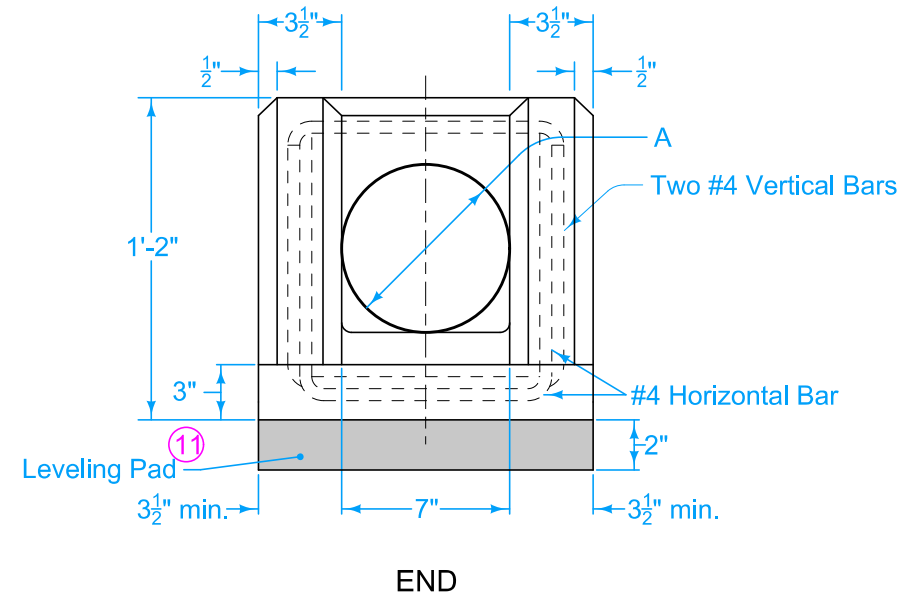
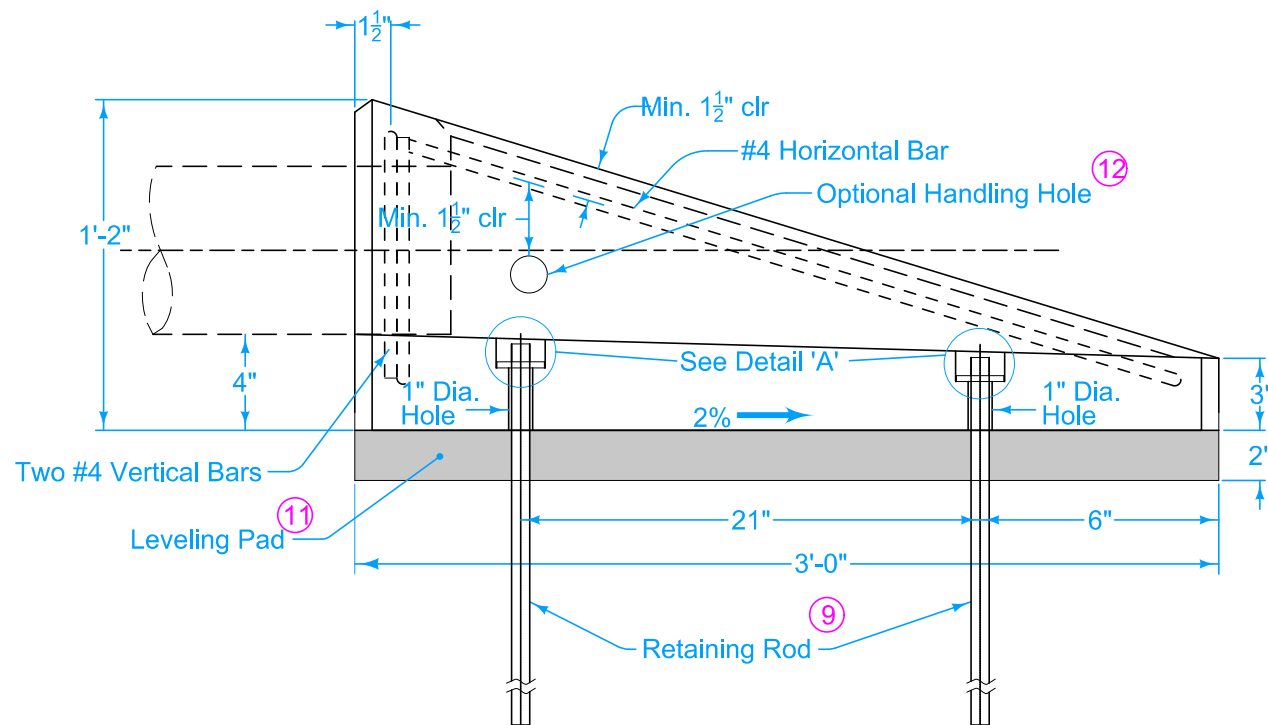

DIMENSION	4" DIA PIPE	6" DIA PIPE
A	5"	7"

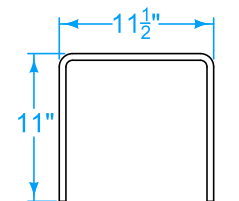
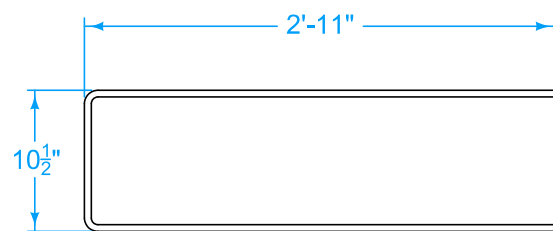

#4 Horizontal Bar

#4 Vertical Bar

BENT BAR SHAPES

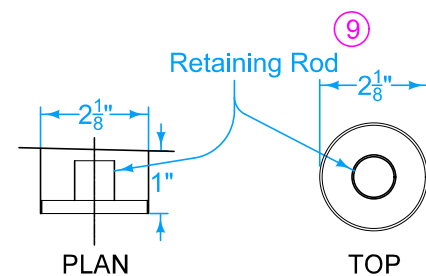

DETAIL 'A'
(Recess for Retaining Rod)

 STANDARD ROAD PLAN	REVISION	
	2	10-17-23
DR-306		SHEET 2 of 2
REVISIONS: Change from granular cap to top soil cap.		
 APPROVED BY DESIGN METHODS ENGINEER		
PRECAST CONCRETE HEADWALL FOR SUBDRAIN OUTLETS		

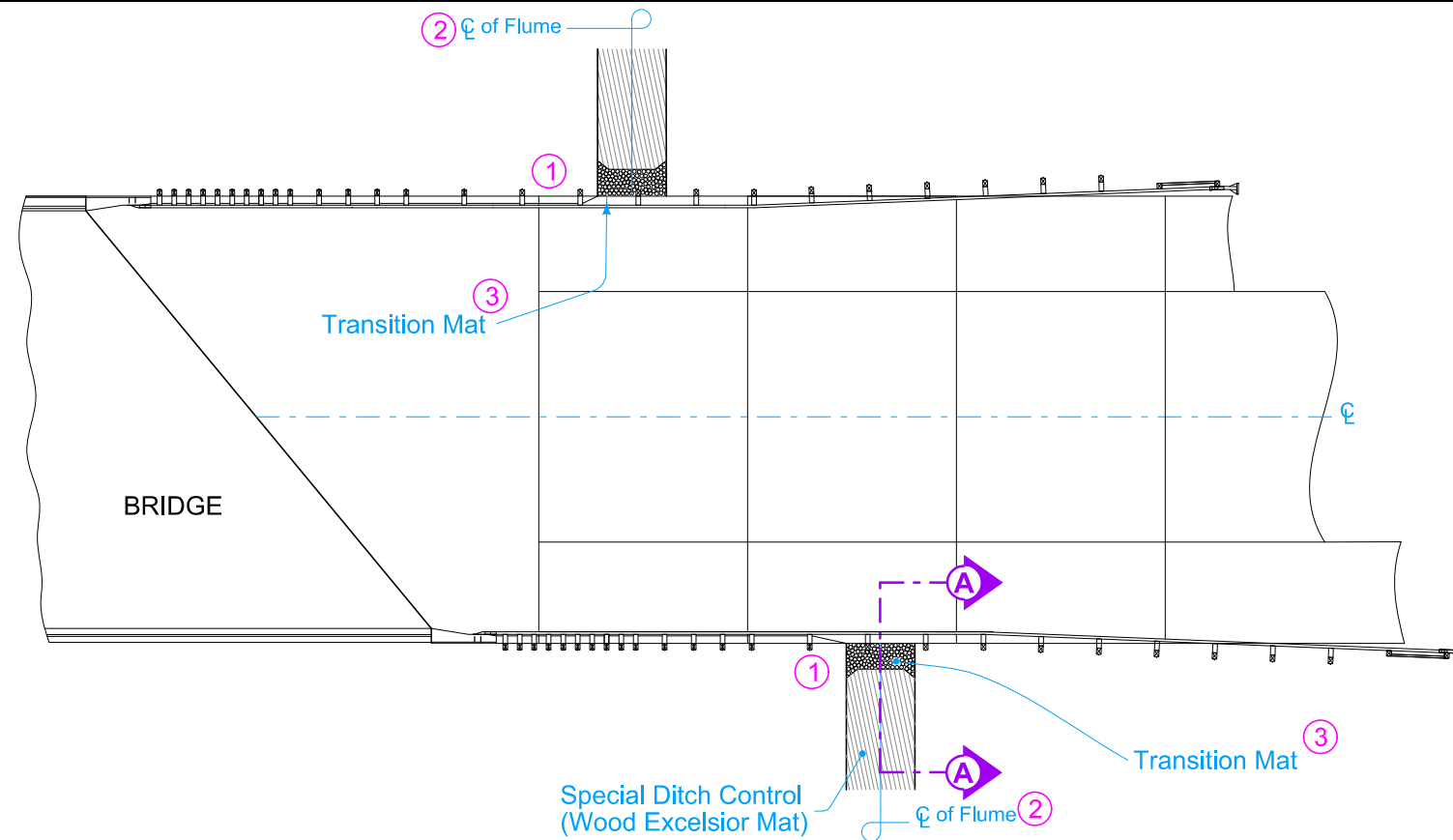

PLAN

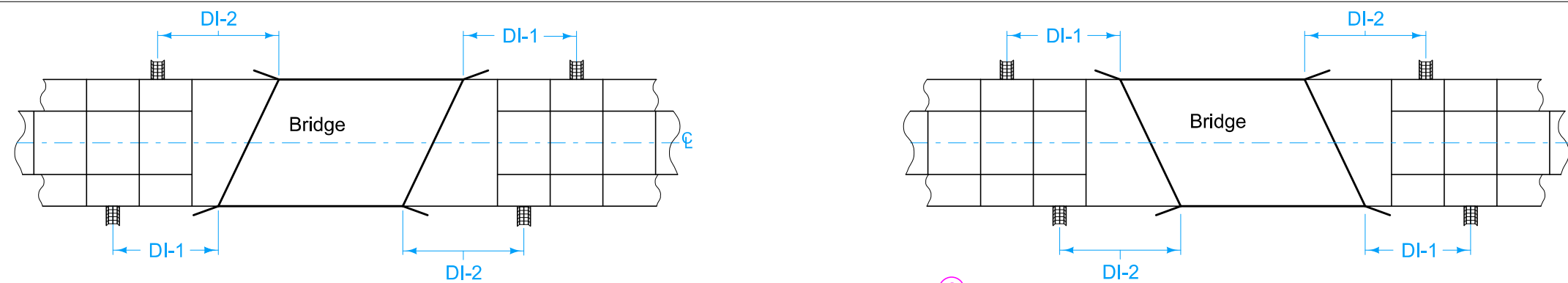

FLUME LOCATIONS
(Skewed Bridge)

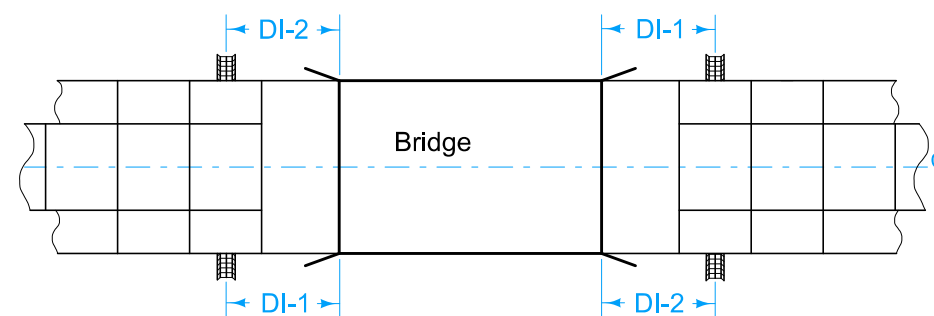

FLUME LOCATIONS
(Non-Skewed Bridge)

Price bid for "Bridge End Drain, DR-401" is full compensation for furnishing, installing, and constructing the Bridge End Drain as shown.

- ① Continue 4 inch sloped curb to edge of flume per section B-B. Refer to BR-201, BR-202, BR-203, BR-204, or BR-205 for details of 4 inch curb.
- ② DI-1 and DI-2 distances measured from center of Bolt Pattern. Refer to BA-202.
- ③ Abut Transition Mat (see EC-105) panels to the edge of the pavement to prevent from being undercut by water. Cut panels to fit around guardrail posts to ensure pavement edge contract. No deduction will be made for area of Transition Mat removed for guardrail posts.

Possible Contract Items:
Bridge End Drain, DR-401

Incidental to Bridge End Drain:
Transition Mat
Seeding and Fertilizing
Soil Fill
Special Ditch Control (Wood Excelsior Mat)
Turf Reinforced Mat, Type 2
Watering for Sod, Special Ditch Control, or Slope Protection
Mobilization for Watering

Possible Tabulation:
104-8A

 STANDARD ROAD PLAN	REVISION	
	7	04-16-24
DR-401		SHEET 1 of 2

REVISIONS: Added reference to BR-202 in note 2.

Shawn Miller
APPROVED BY DESIGN METHODS ENGINEER

SCOUR PROTECTION
FOR BRIDGE END DRAIN

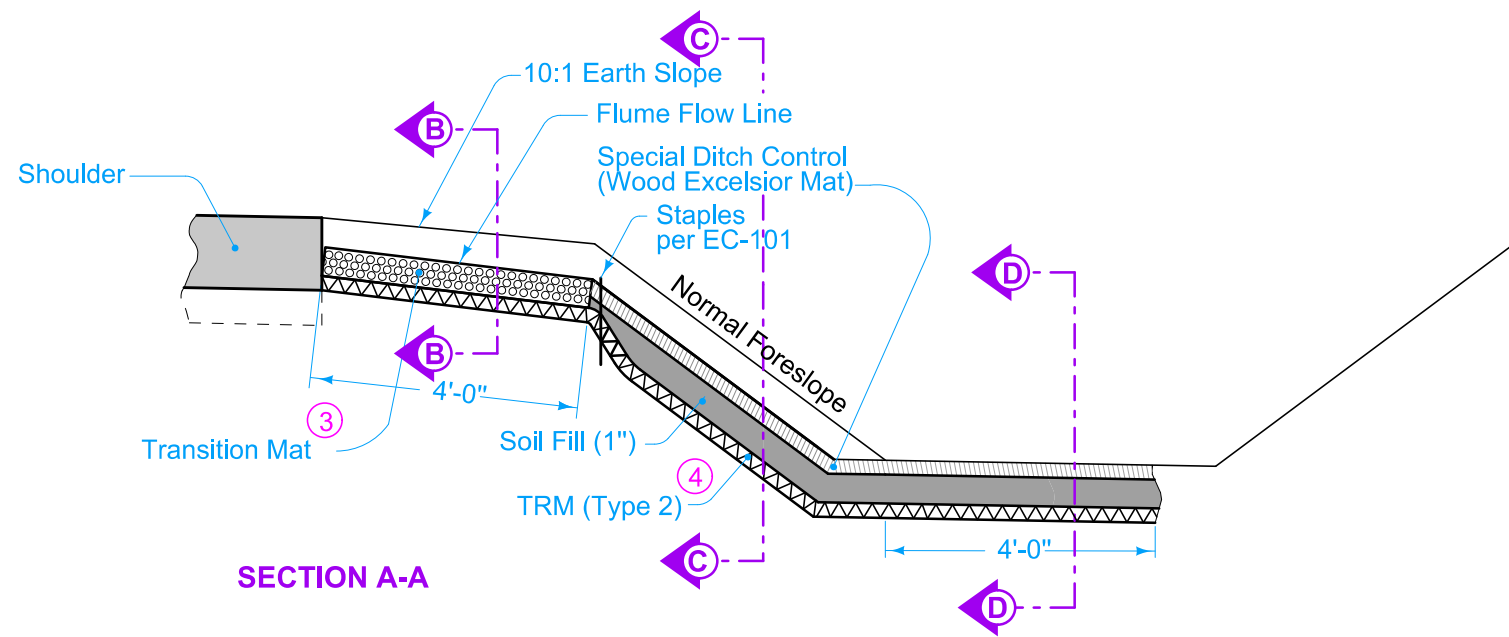

- ① Continue 4 inch sloped curb to edge of flume per section B-B. Refer to BR-201, BR-202, BR-203, BR-204, or BR-205 for details of 4 inch curb.
- ③ Abut Transition Mat (see EC-105) panels to the edge of the pavement to prevent from being undercut by water. Cut panels to fit around guardrail posts to ensure pavement edge contact. No deduction will be made for area of Transition Mat panel removed for guardrail posts.
- ④ Extend TRM (see EC-104) flume 4 feet beyond toe of slope.
- ⑤ Transition the flume flow line depth from 3 inches at the downstream edge of Transition Mat to 8 inches with an approximate transition rate of 1 inch vertical per 1 foot horizontal.
- ⑥ Transition the flume flow line depth from 8 inches at the toe of slope to 0 inches with an approximate transition rate of 2 inches vertical per 1 foot horizontal.

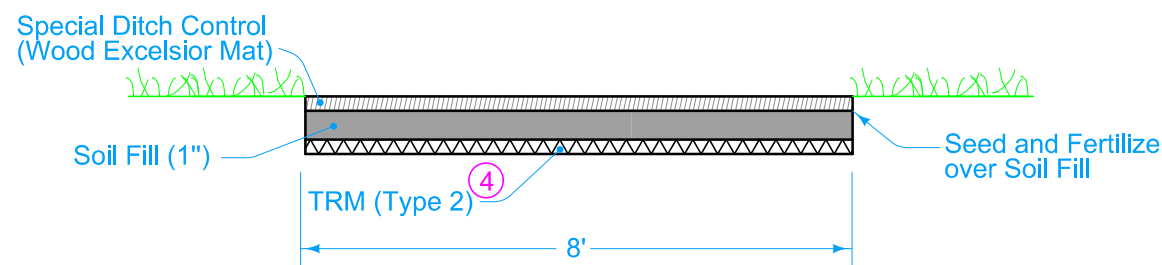
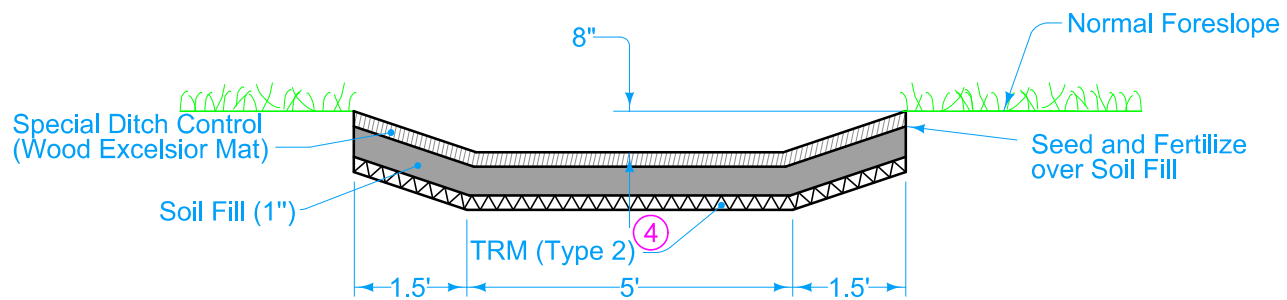
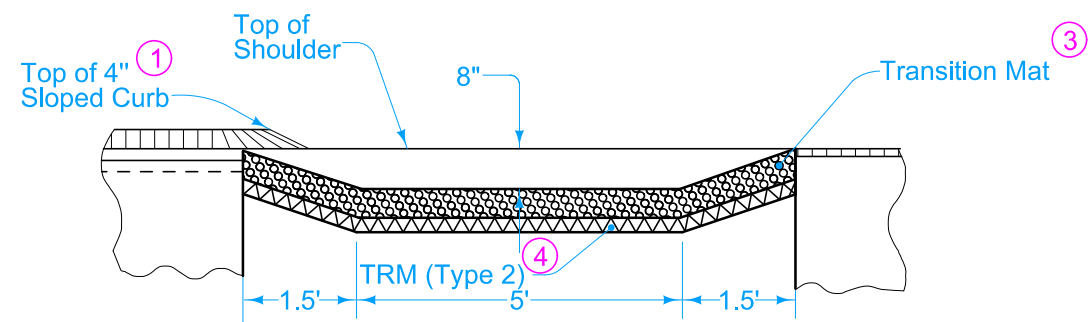

 IOWA DOT	REVISION	
	7	04-16-24
STANDARD ROAD PLAN		DR-401
		SHEET 2 of 2

REVISIONS: Added reference to BR-202 in note 2.

Shawn Miller
APPROVED BY DESIGN METHODS ENGINEER

**SCOUR PROTECTION
FOR BRIDGE END DRAIN**

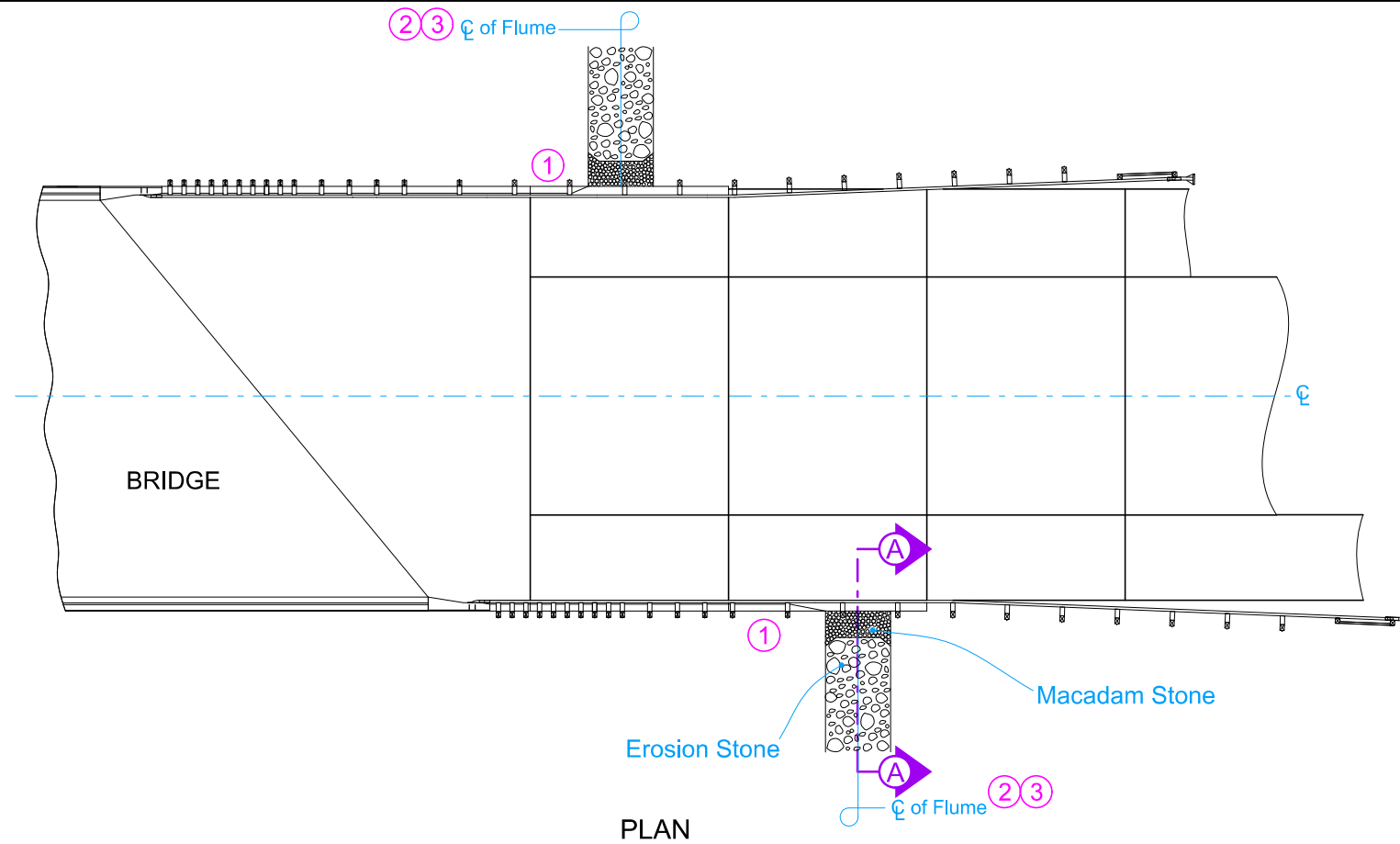

- Price bid for "Bridge End Drain, DR-402" is full compensation for furnishing, installing, and constructing the Bridge End Drain as shown.
- ① Continue 4 inch sloped curb to edge of flume per section B-B. Refer to BR-201, BR-202, BR-203, BR-204, or BR-205 for details of 4 inch curb.
 - ② DI-1 and DI-2 distances measured from center of Bolt Pattern. Refer to BA-202.
 - ③ Extend rock flume to toe of backslope. If no backslope exists, extend rock flume a minimum of 4 feet beyond the toe of foreslope.

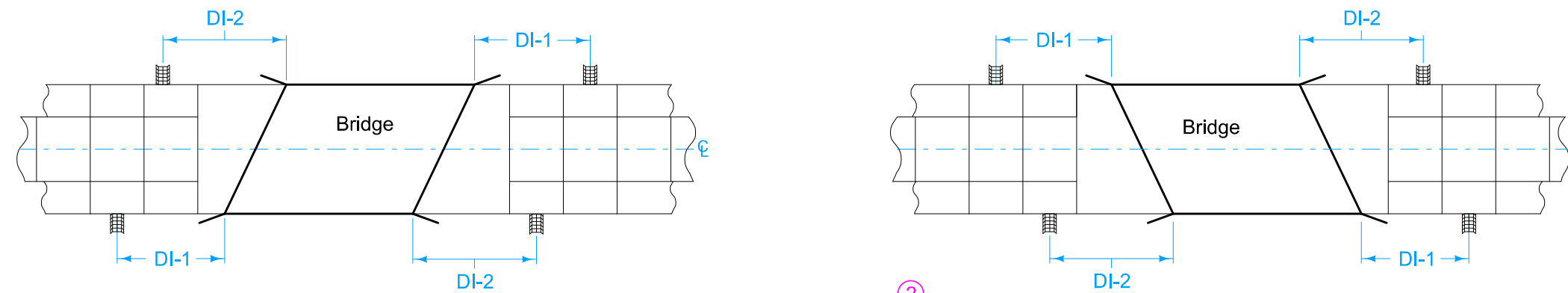

FLUME LOCATIONS
(Skewed Bridge)

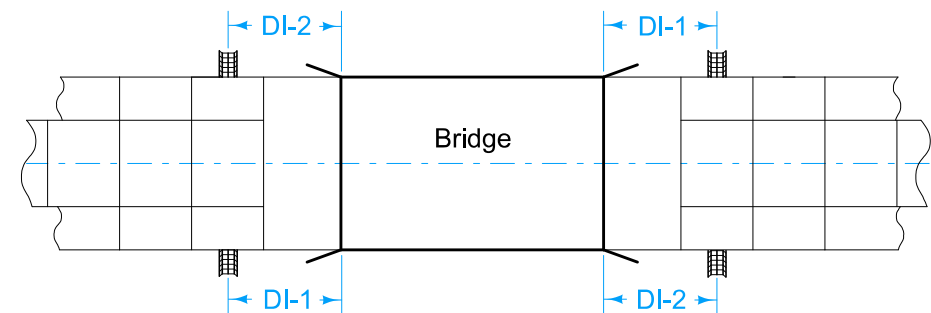

FLUME LOCATIONS
(Non-Skewed Bridge)

Possible Contract Items:
Bridge End Drain, DR-402

Incidental to Bridge End Drain:
Macadam Stone Base Material
Erosion Stone
Engineering Fabric
Excavation, hauling, and disposing of material

Possible Tabulation:
104-8A

 STANDARD ROAD PLAN	REVISION	
	7	04-16-24
DR-402		SHEET 1 of 2

REVISIONS: Added reference to BA-202 in note 2.

Shawn Miller
APPROVED BY DESIGN METHODS ENGINEER

**ROCK FLUME FOR
BRIDGE END DRAIN**

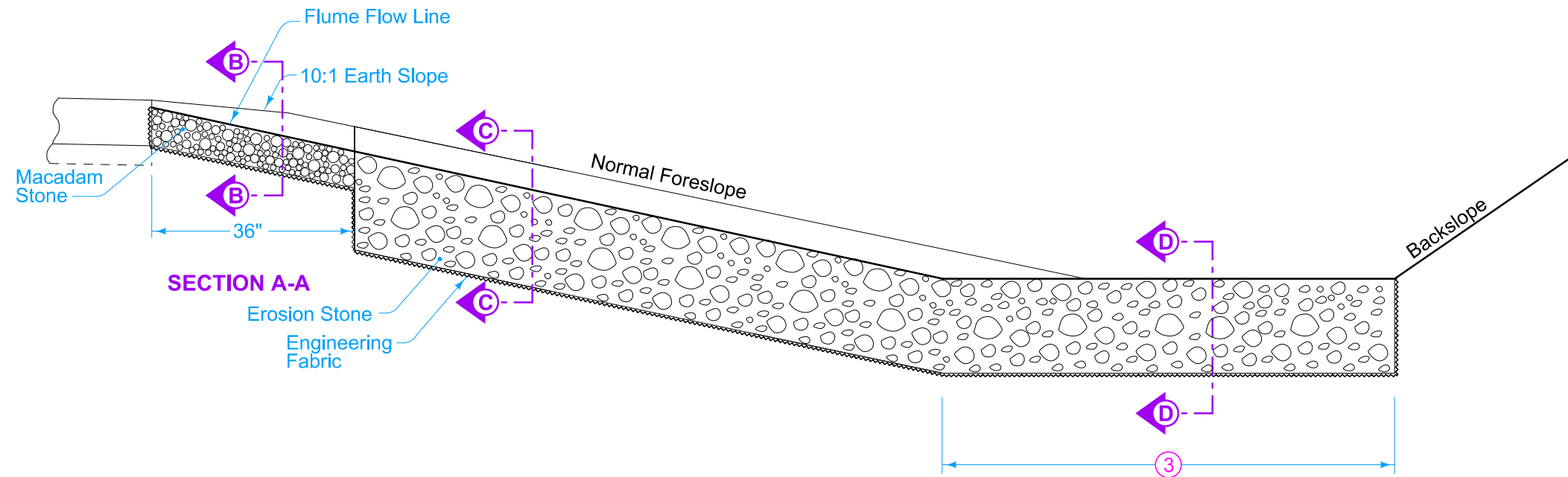

- ① Continue 4 inch sloped curb to edge of flume per section B-B. Refer to BR-201, BR-202, BR-203, BR-204, or BR-205 for details of 4 inch curb.
- ③ Extend flume to toe of backslope. If no backslope exists, extend rock flume a minimum of 4 feet beyond the toe of foreslope.
- ④ Transitions from 2 inches at edge of pavement to 8 inches within 3 feet.
- ⑤ Transition the flume flow line depth from 8 inches at the toe of slope to 0 inches with an approximate transition rate of 2 inches per 1 foot horizontal.

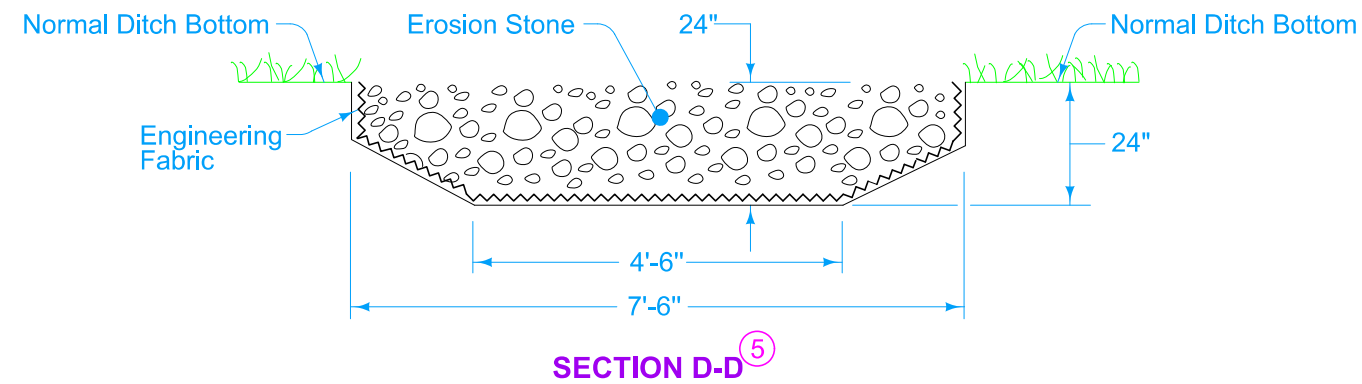
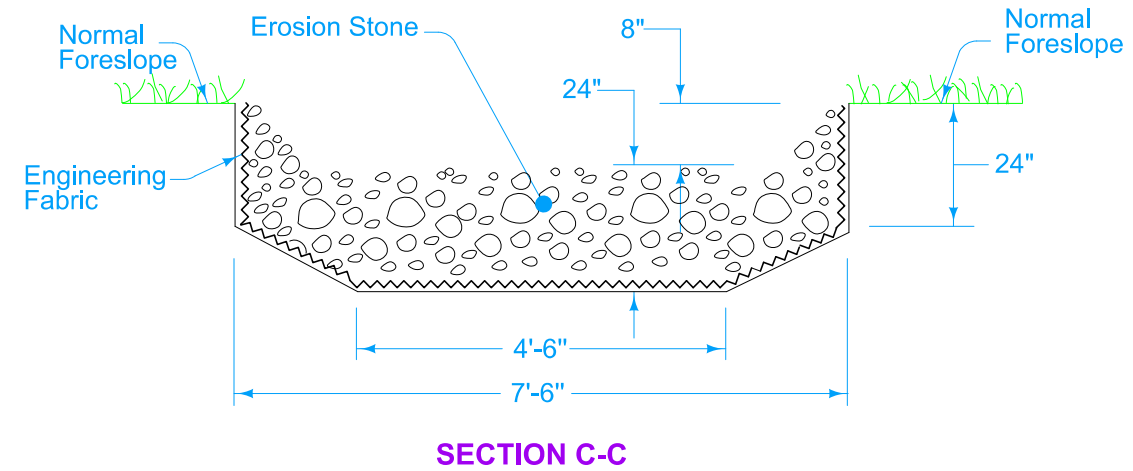
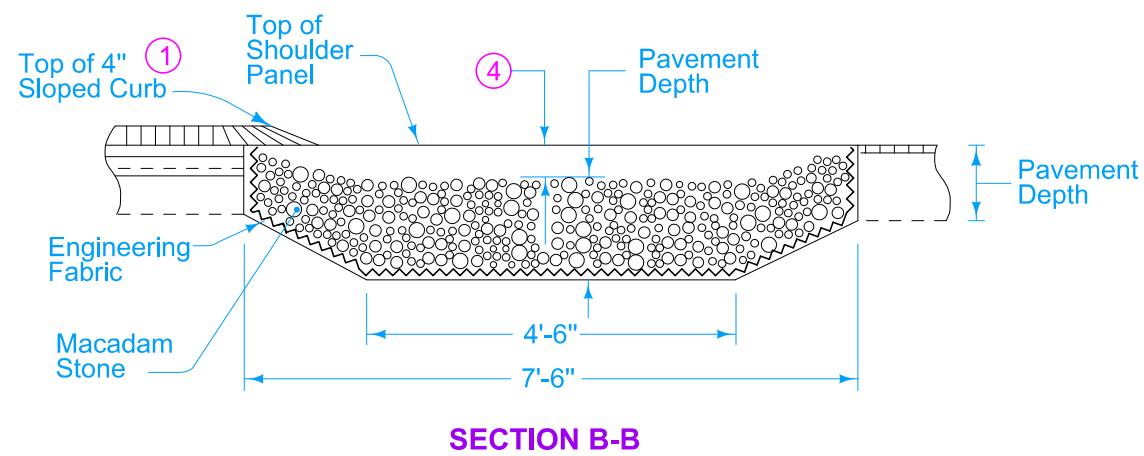

 IOWA DOT	REVISION	
	7	04-16-24
STANDARD ROAD PLAN		
DR-402		
SHEET 2 of 2		

REVISIONS: Added reference to BA-202 in note 2.

Shawn Miller
APPROVED BY DESIGN METHODS ENGINEER

**ROCK FLUME FOR
BRIDGE END DRAIN**

Install the Type "A" Diaphragm (anti-seep device for use on letdown structures) directly below the upstream shoulder of the dike.

Type "A" Diaphragm consists of a sheet of corrugated metal of the dimensions indicated hereon and of the same thickness as the pipe used for culvert pipe. Fabricate this sheet from one or more sheets of corrugated metal. Lap a minimum of one corrugation and weld or rivet at a minimum of 3 inch centers along the seam if two or more sheets are used. Weld the sheet on both sides to a standard half connecting band of dimensions indicated hereon. Securely attach this assembly to the pipe by means of two 3/8 inch diameter rods of appropriate length placed in two adjacent valleys of the corrugated pipe and threaded with double nut and washer.

Details are shown using corrugated metal culvert pipe. Make appropriate modifications as indicated, subject to the approval of the Engineer, as necessary where concrete culvert pipe is used. Use plastic diaphragms when connecting to plastic pipe.

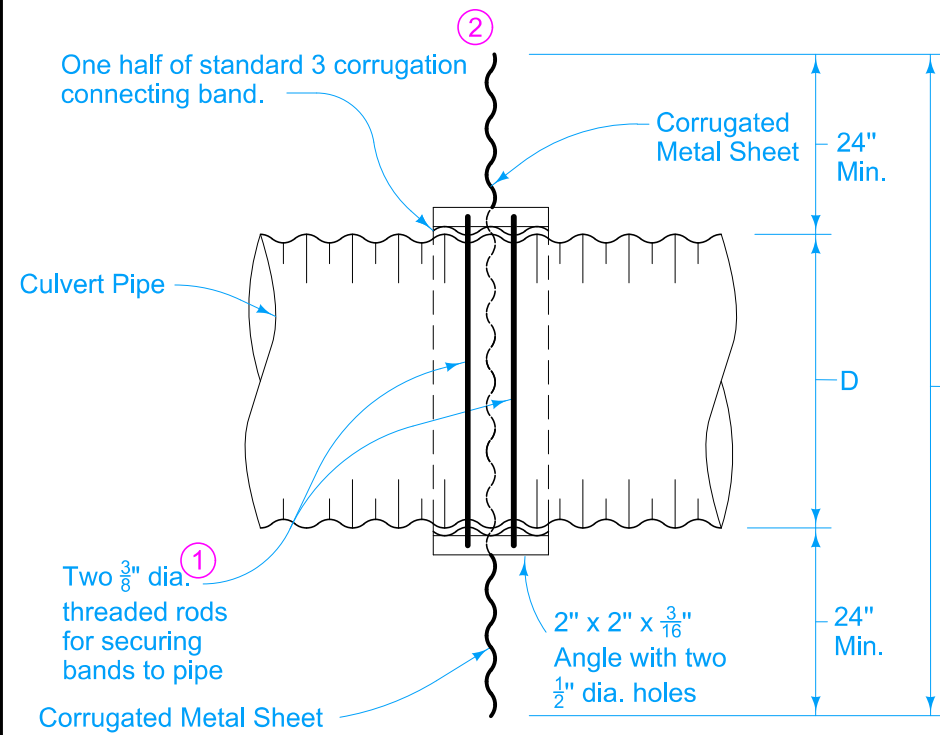

PLAN VIEW

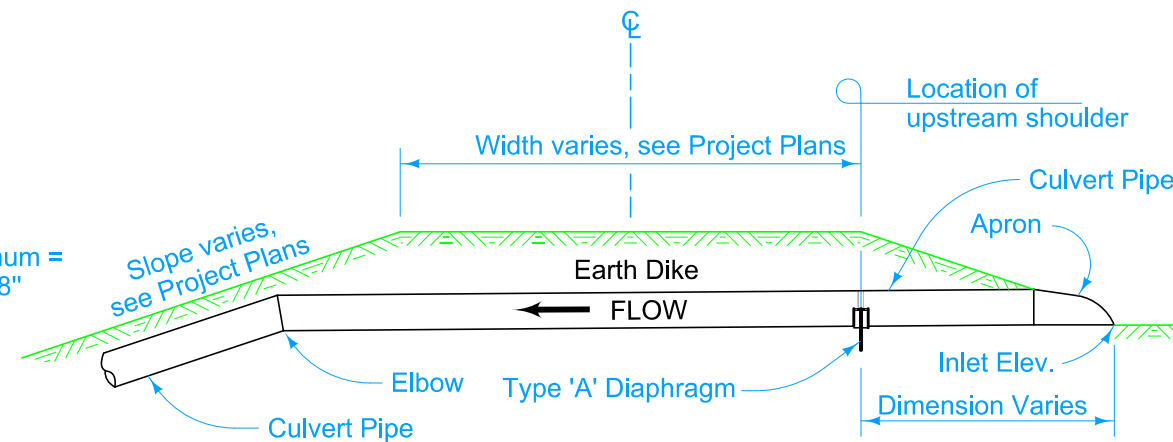

DIAPHRAGM INSTALLATION

Place diaphragm below upstream shoulder of dike unless otherwise specified on Project Plans.

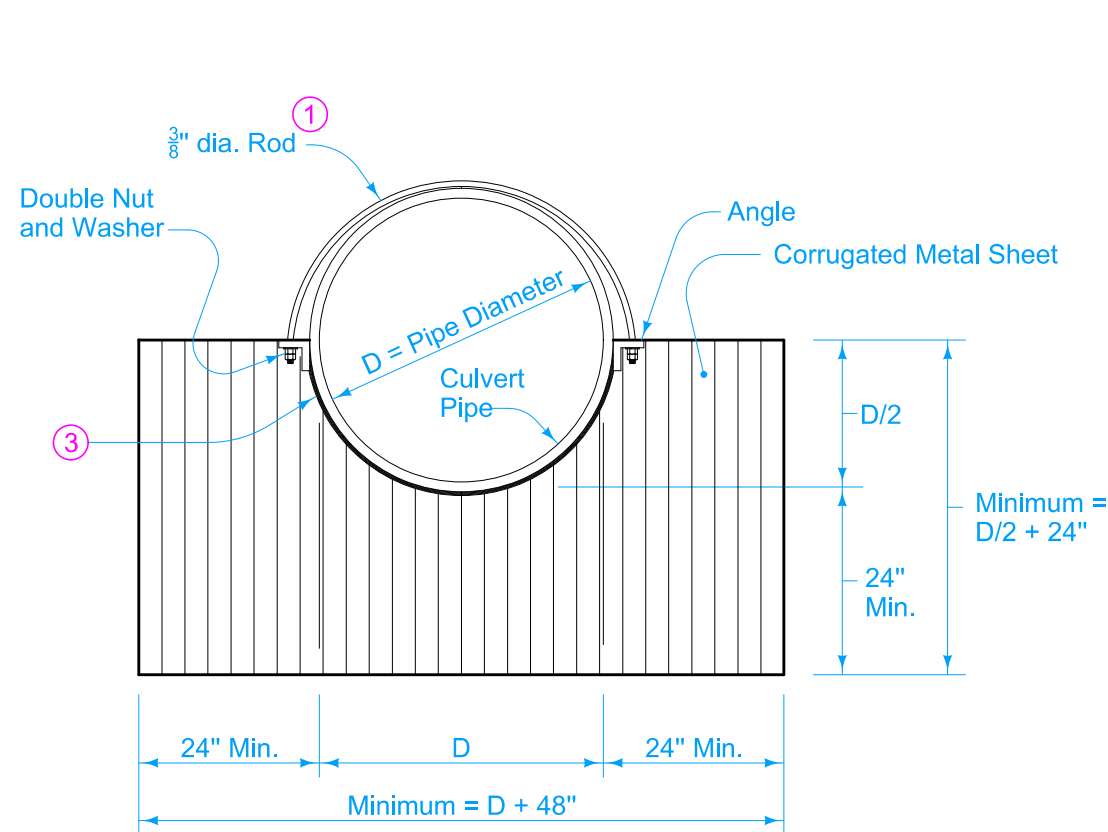

END VIEW

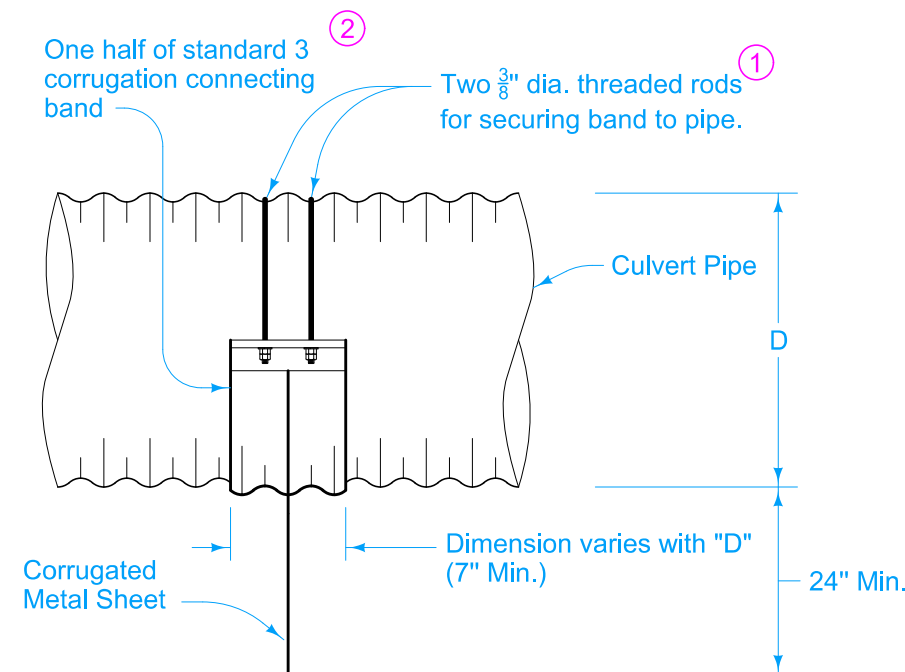

SIDE VIEW

- ① Normal half of connecting band may be used in lieu of rods when approved by the Engineer.
- ② Use flat steel band of equivalent dimensions where Type "A" Diaphragm is to be installed on Concrete Culvert pipe.
- ③ Weld corrugated metal sheet to the connecting band using a continuous weld. Shape to fit outside pipe diameter.

 STANDARD ROAD PLAN	REVISION	
	1	04-17-18
DR-501		SHEET 1 of 1

REVISIONS: Added Designer Info button.

Shawn Miller
APPROVED BY DESIGN METHODS ENGINEER

**CORRUGATED METAL
TYPE "A" DIAPHRAGM**

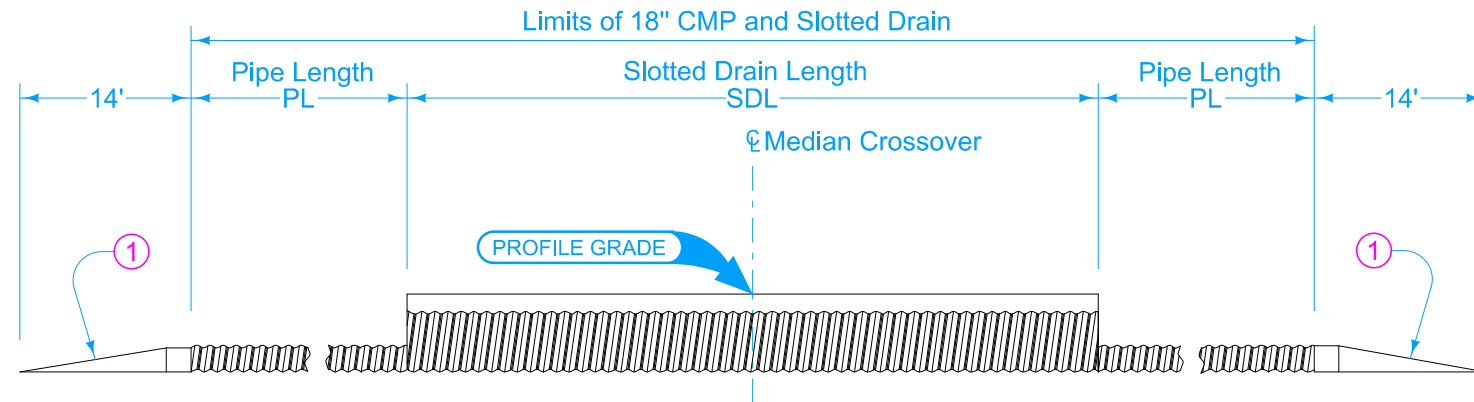

LONGITUDINAL SECTION THROUGH CMP SLOTTED DRAIN ASSEMBLY

- ① Beveled pipe and guard. See DR-212.
- ② During construction of crossover pavement, cover slotted drain with duct tape or wood block.
- ③ Slotted grate 6 inches high x 1 3/4 inches opening width. Use 3/16 inch material for spacers and bearing bars (sides).

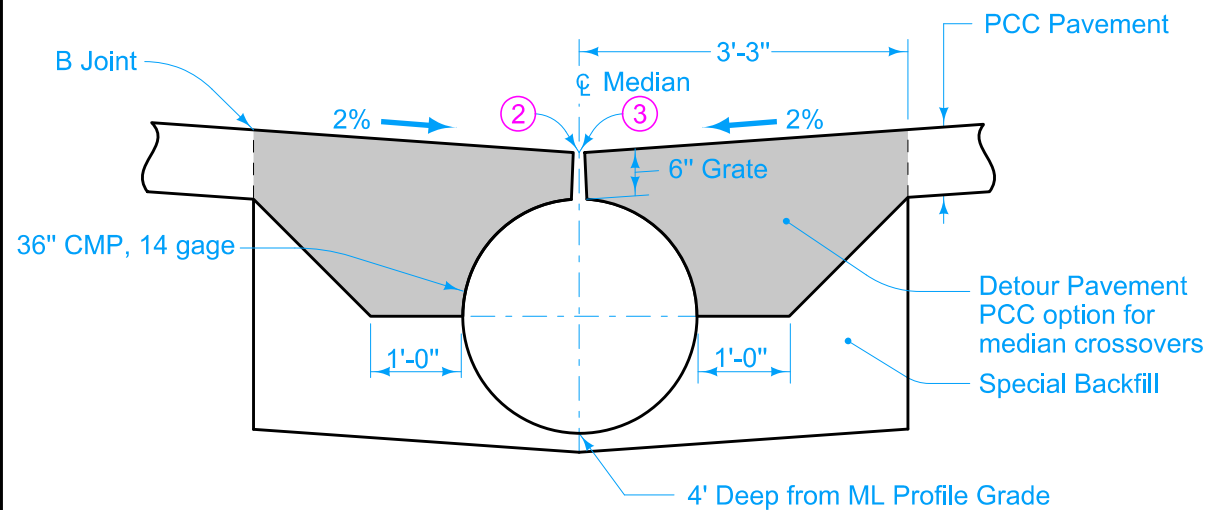

PCC PAVEMENT SITUATION

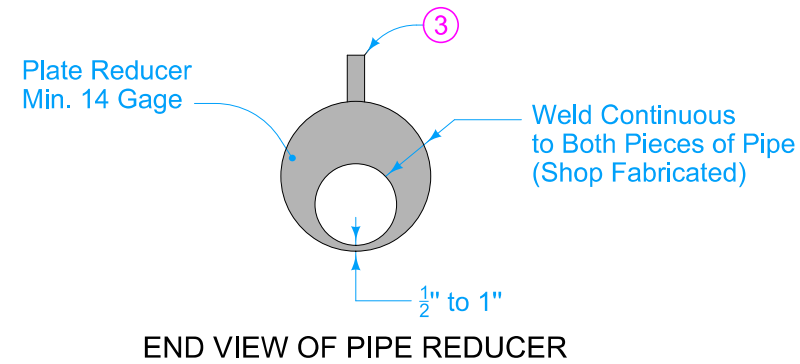

END VIEW OF PIPE REDUCER

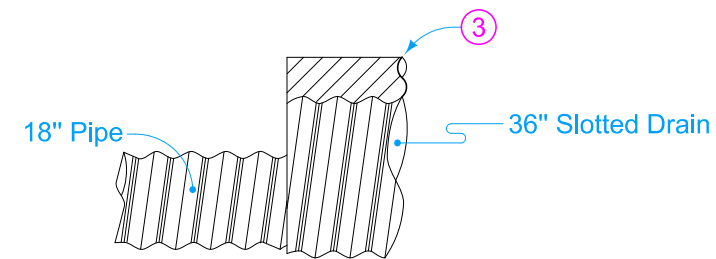

SIDE VIEW OF PIPE REDUCER

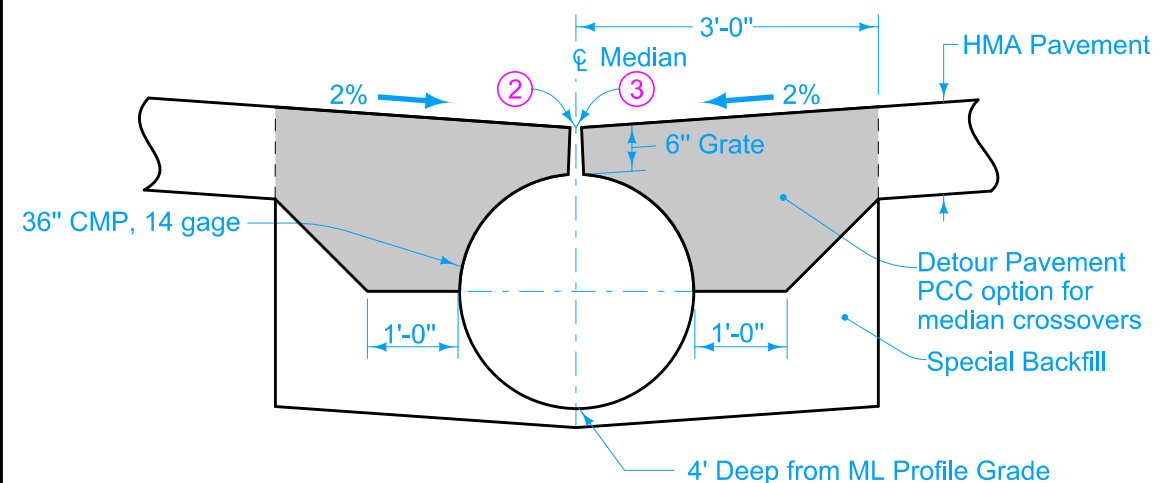

HMA PAVEMENT SITUATION

Possible Contract Items:
 Beveled Pipe and Guard
 Culvert, Unclassified Roadway Pipe, 18" Dia.
 Detour Pavement
 Drain, Corrugated Metal Pipe Slotted, 36", w/6" Grate
 Special Backfill

Possible Tabulation:
 112-8

TABLE OF QUANTITIES					
Standard Road Plan	PV-500	PV-503	PV-506	PV-509	PV-512
Median Width	50'	64'	68.24'	82'	100'
SDL Slotted Drain Length	116'	110'	110'	102'	94'
PL Pipe Length	132'	110'	104'	90'	76'
Bid Items					
36" Corrugated Metal Slotted Pipe Drain w/6" Grate	116'	110'	110'	102'	94'
18" dia. Corrugated Metal Roadway Pipe Culvert	264'	220'	208'	180'	152'

	REVISION	
	1	10-18-16
STANDARD ROAD PLAN		DR-502
SHEET 1 of 1		

REVISIONS: Changed 'Unclassified Entrance Pipe' to 'Unclassified Roadway Pipe' to coincide with Tab 112-8, Median Crossovers.

Steve Miller
 APPROVED BY DESIGN METHODS ENGINEER

**SLOTTED DRAIN FOR
 MEDIAN Crossovers**

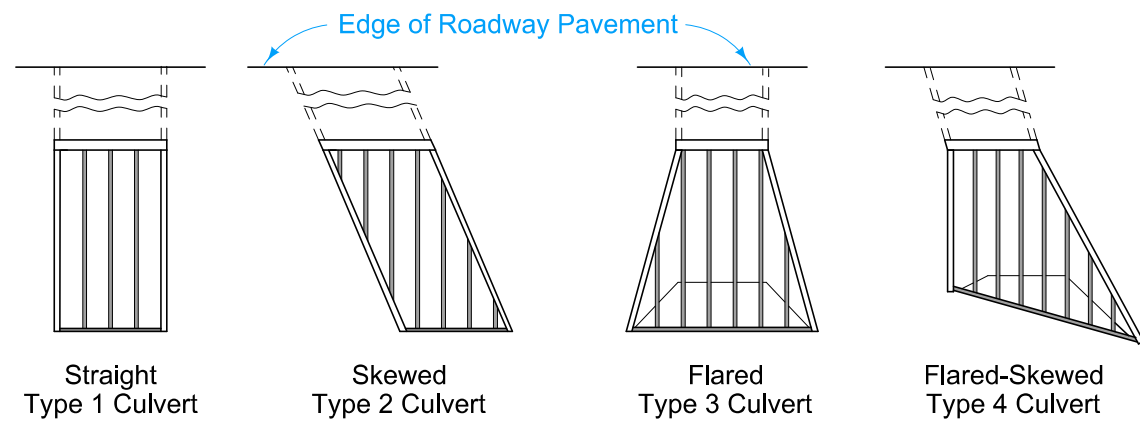

INSTALLATION TYPES

Grate bars to be perpendicular to direction of traffic flow.

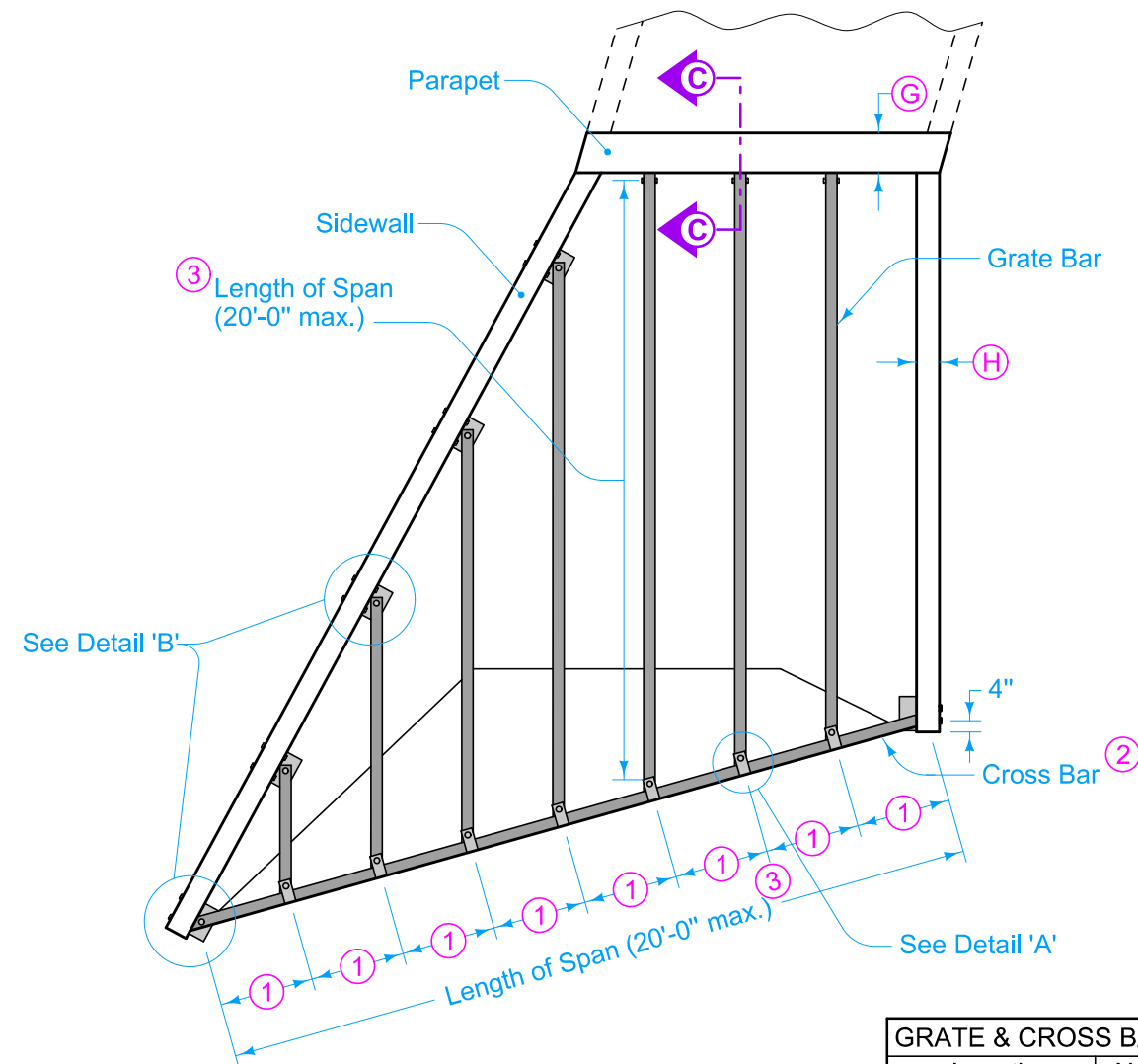

INSTALLATION PLAN

GRATE & CROSS BAR SIZE REQUIREMENTS		
Length of Span less than 12'	Nominal Pipe Size 3.0" (2)	O.D. Size 3.5"
12'-16'	3.5"	4.0"
greater than 16'	4.0"	4.5"

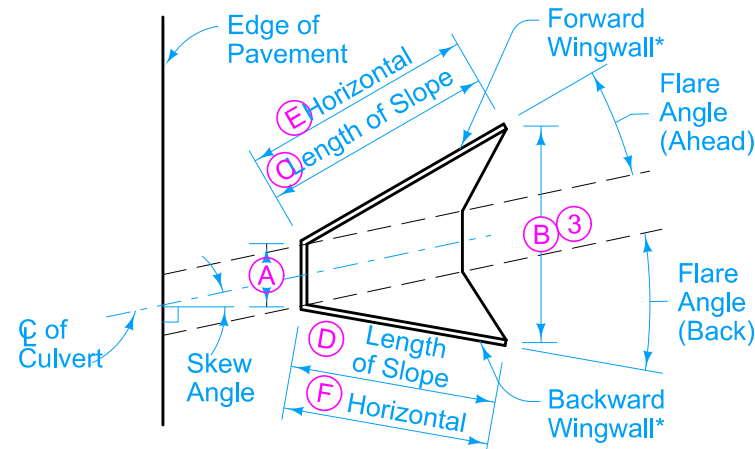

* From Roadway Stationing
TOP VIEW

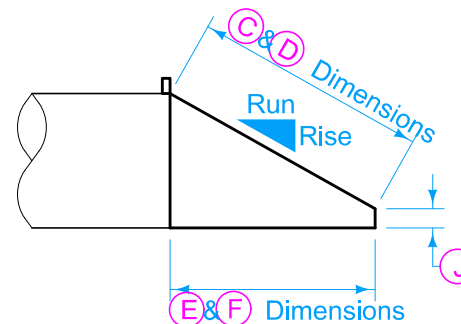

SIDE VIEW DETAILS OF DIMENSIONS

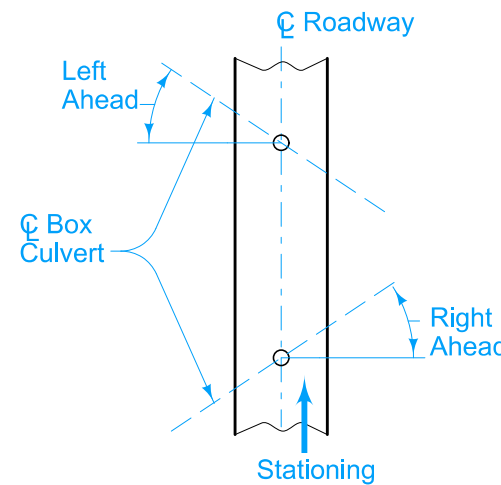

SKEW ANGLE DETERMINATION

- ① Equal spaces 24 inches minimum, 30 inches maximum, edge of sidewall to center of bracket or center to center of bracket.
- ② Cross Bar diameter equal to or greater than Grate Bar diameter.
- ③ If more than 20 feet, midspan support is required. Refer to sheets 3 and 4.

The dimensions shown in the "Tabulation of Safety Grate Treatment" are from the original construction plans. Verify these dimensions at the site before fabricating components.

Submit shop drawings. Approval of drawings is not required as part of the fabrication process. Drawings will be used to document the item as constructed.

Use correct pipe diameters and correct dimensions. Ensure safety grate fits properly into the headwall opening.

Reinforcing steel may be encountered when drilling holes through the existing structure wall.

Install bolts and lock nuts complying with Article 4153.06 of the Standard Specifications at all locations as shown. Use brackets that comply with ASTM A36 and are galvanized per ASTM A123. Use steel washers meeting the dimensional requirements of Materials I.M. 453.07.

Furnish Schedule 40 Pipe meeting the requirements of Article 4153.05 of the Standard Specifications. Galvanize all pipes, fittings, and hardware after all cutting, welding, drilling and fabrication. In the shop drawings, show members planned for field cutting and drilling to provide for installation tolerances. Repair galvanizing of those members according to Materials I.M. 410.

Gas Metal-Arc and Flux-Cored Arc welding may be used for welding incidental items as indicated on this sheet, provided that the fabricator furnishes certifications for the gas and uses approved filler metal and qualified welders approved by the Iowa DOT.

Payment for "Safety Grate, (Type 1,2,3, or 4), Culvert" is full compensation for furnishing all materials and work necessary to fabricate and install the grate system as required for each headwall opening.

Possible Contract Items:
Safety Grate, (Type 1, 2, 3, or 4), Culvert

Possible Tabulation:
108-24

	REVISION	
	1	04-21-20
STANDARD ROAD PLAN		DR-503
REVISIONS: Added Designer Info button.		SHEET 1 of 4
 APPROVED BY DESIGN METHODS ENGINEER		
SAFETY GRATES FOR BOX CULVERTS		

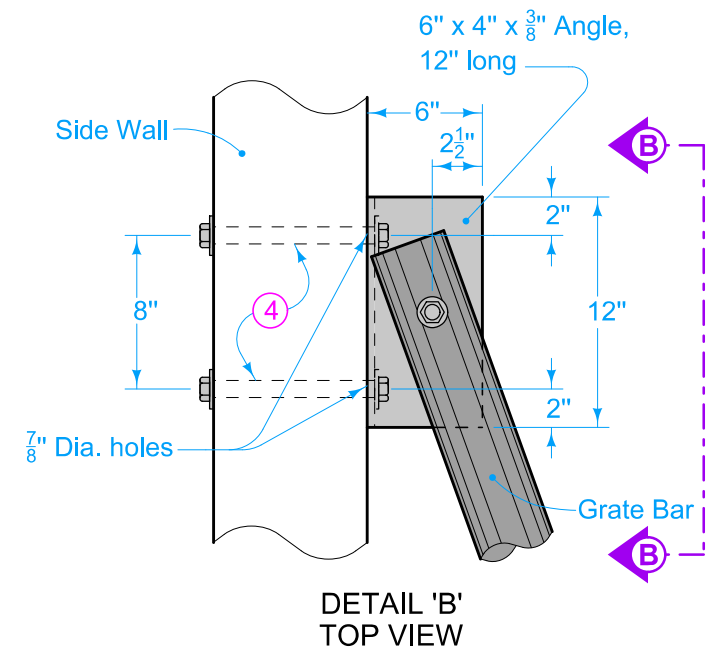
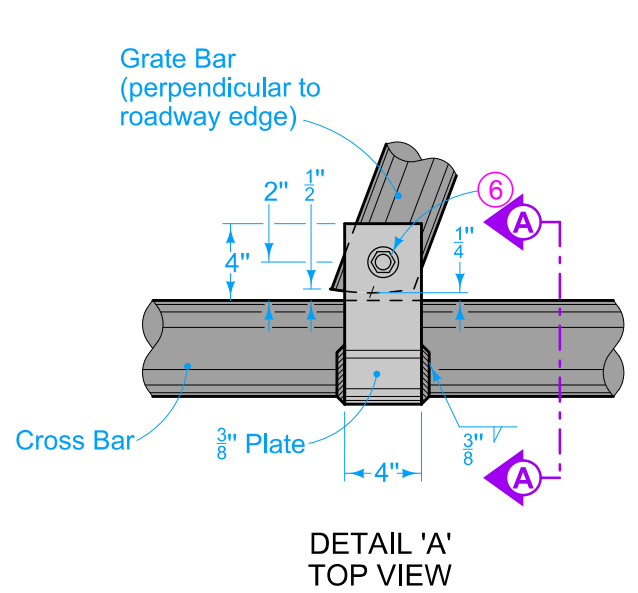

- ④ Drill $\frac{7}{8}$ inch diameter holes using equipment designed to cut through concrete and reinforcing steel.
- ⑤ Bend plates or strips without cracking material.
- ⑥ $\frac{3}{4}$ inch bolt, lock nut and washers. All holes are to be $\frac{7}{8}$ inch diameter.
- ⑦ Shim thickness equal to difference in diameters of Grate Bar and Cross Bar.

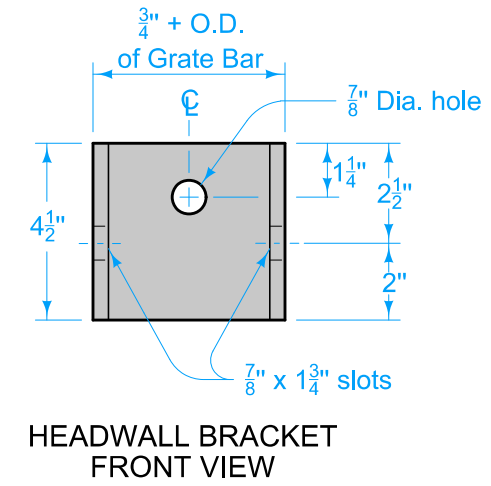
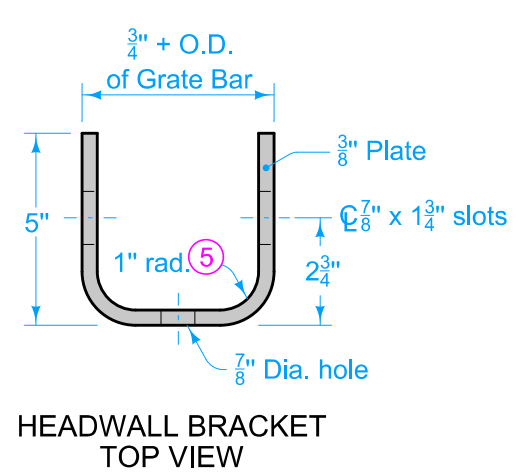
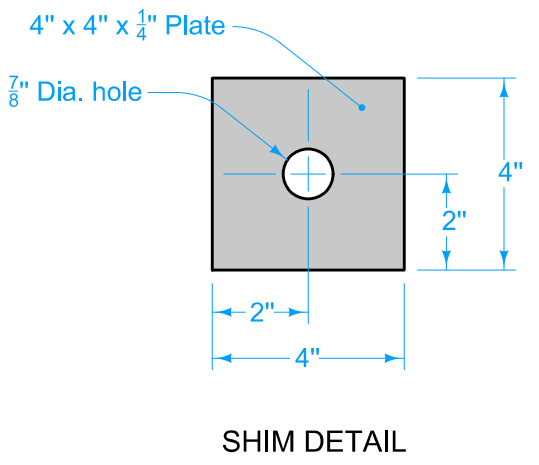
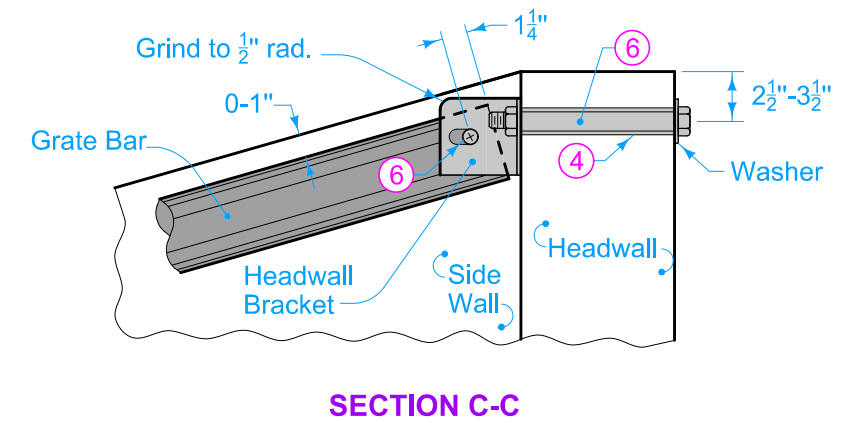
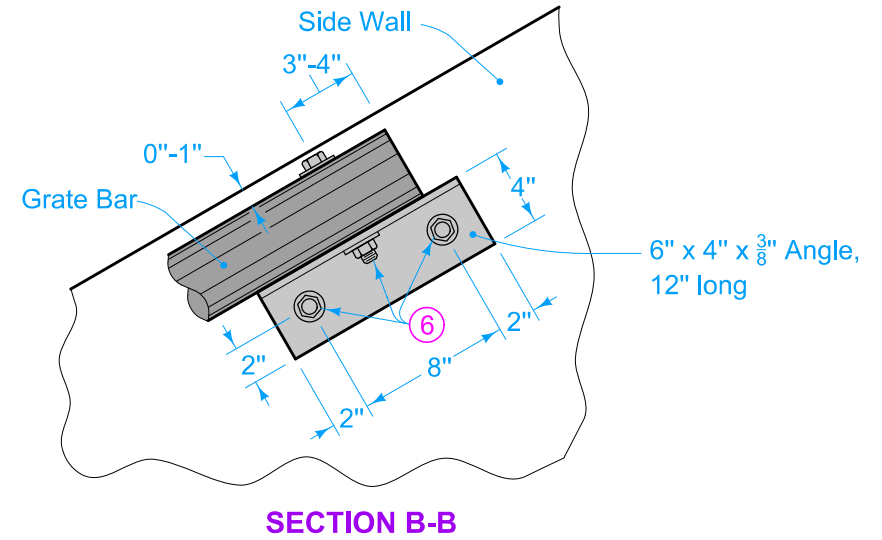
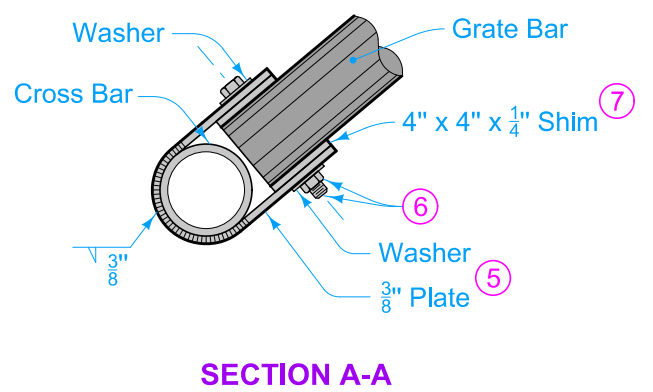

 STANDARD ROAD PLAN	REVISION	
	1	04-21-20
	DR-503	
SHEET 2 of 4		
REVISIONS: Added Designer Info button.		
 APPROVED BY DESIGN METHODS ENGINEER		
SAFETY GRATES FOR BOX CULVERTS		

③ If more than 20 feet, midspan support is required. Refer to sheets 3 and 4.

⑧ Length of span (20 feet maximum).

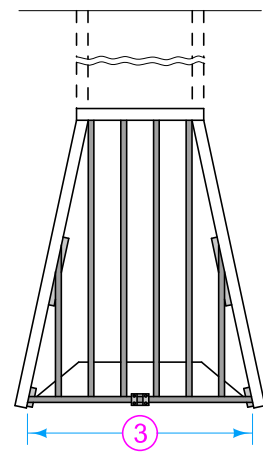

CASE 1

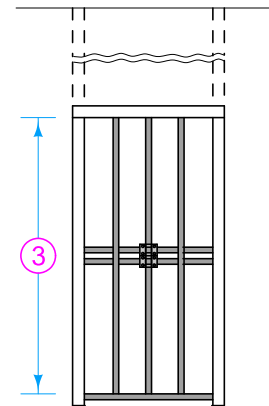

CASE 2

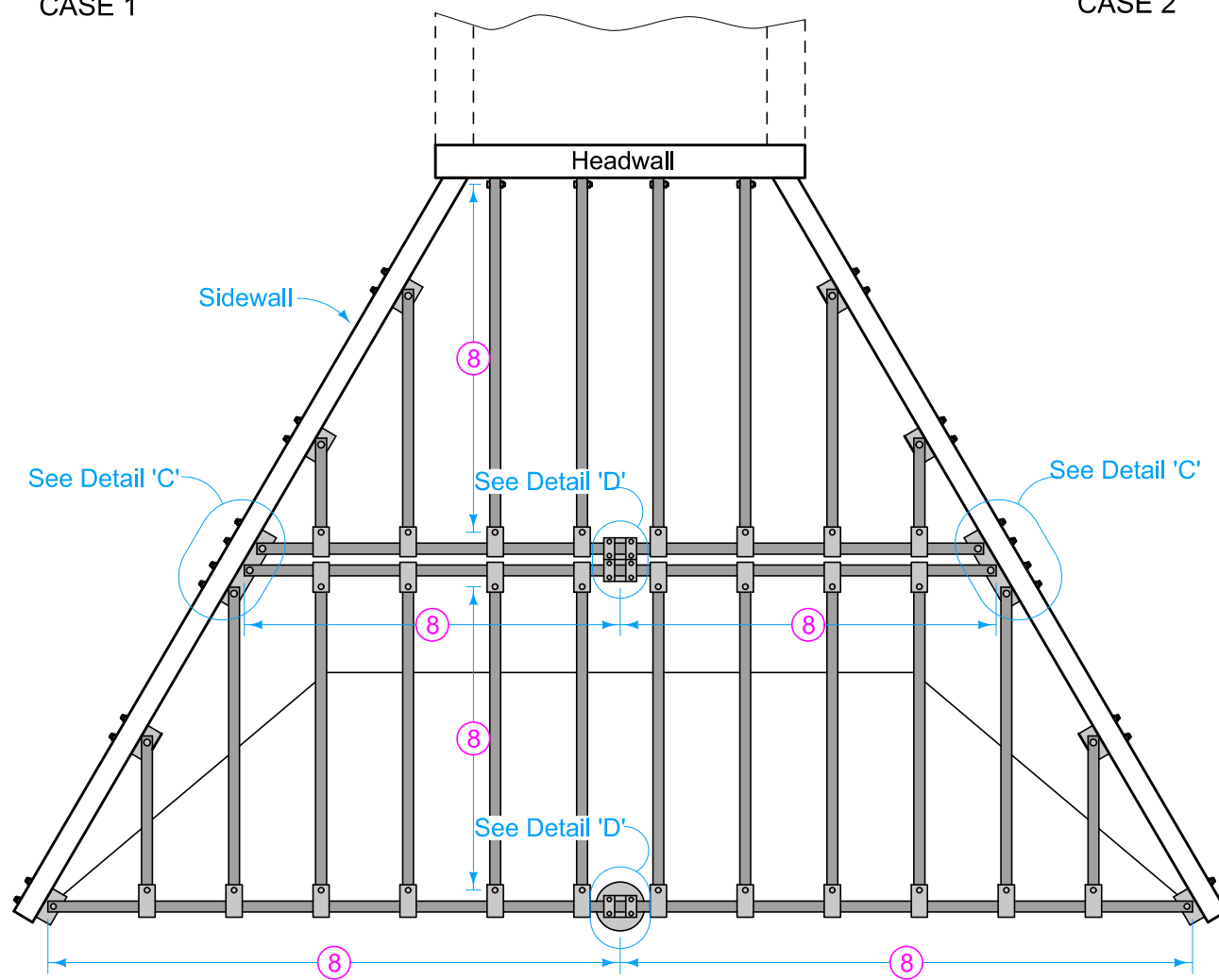

INSTALLATION PLAN WITH MIDSPAN SUPPORT

	REVISION	
	1	04-21-20
STANDARD ROAD PLAN		DR-503
		SHEET 3 of 4

REVISIONS: Added Designer Info button.

Steve Miller
APPROVED BY DESIGN METHODS ENGINEER

**SAFETY GRATES
FOR BOX CULVERTS**

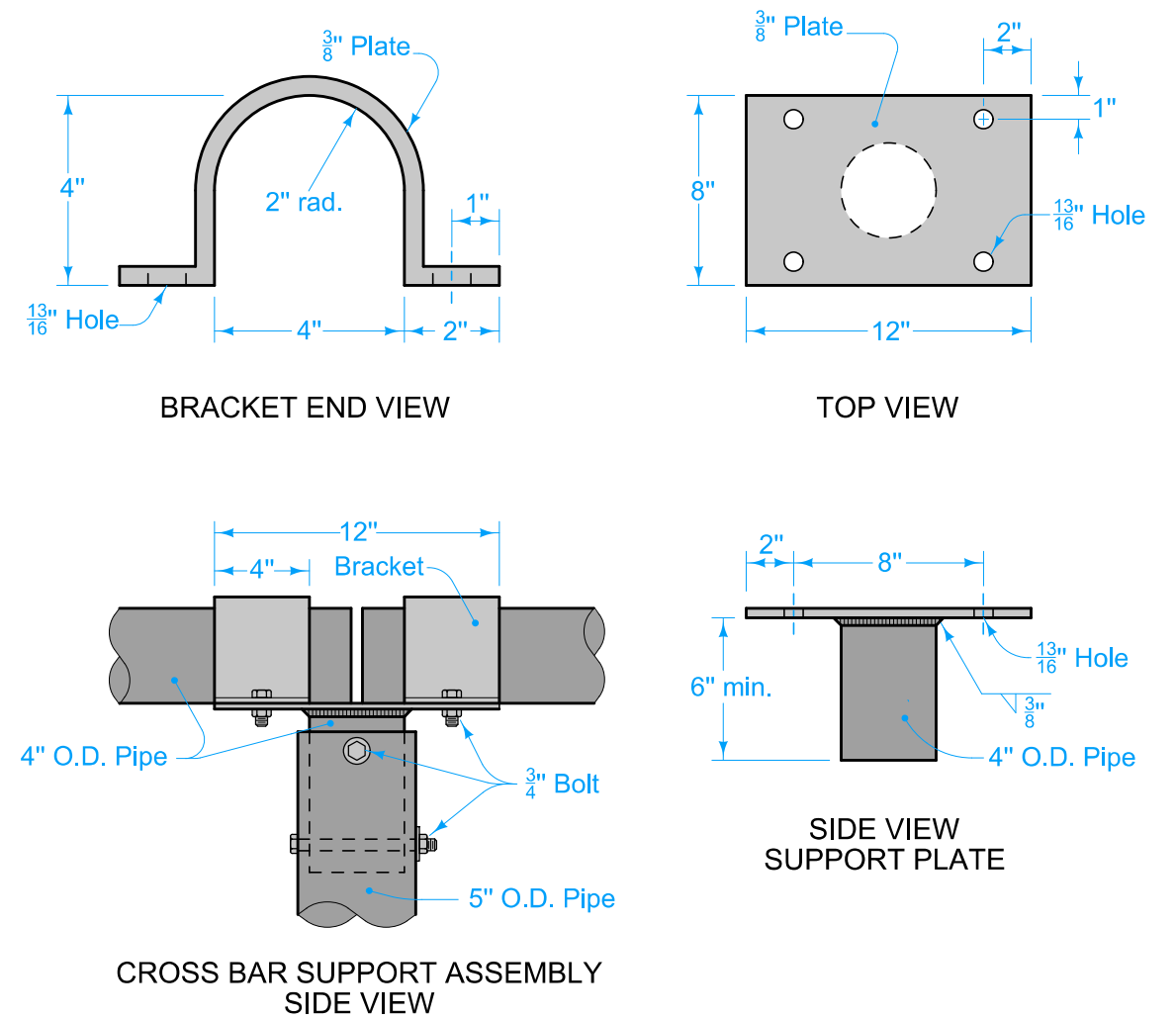
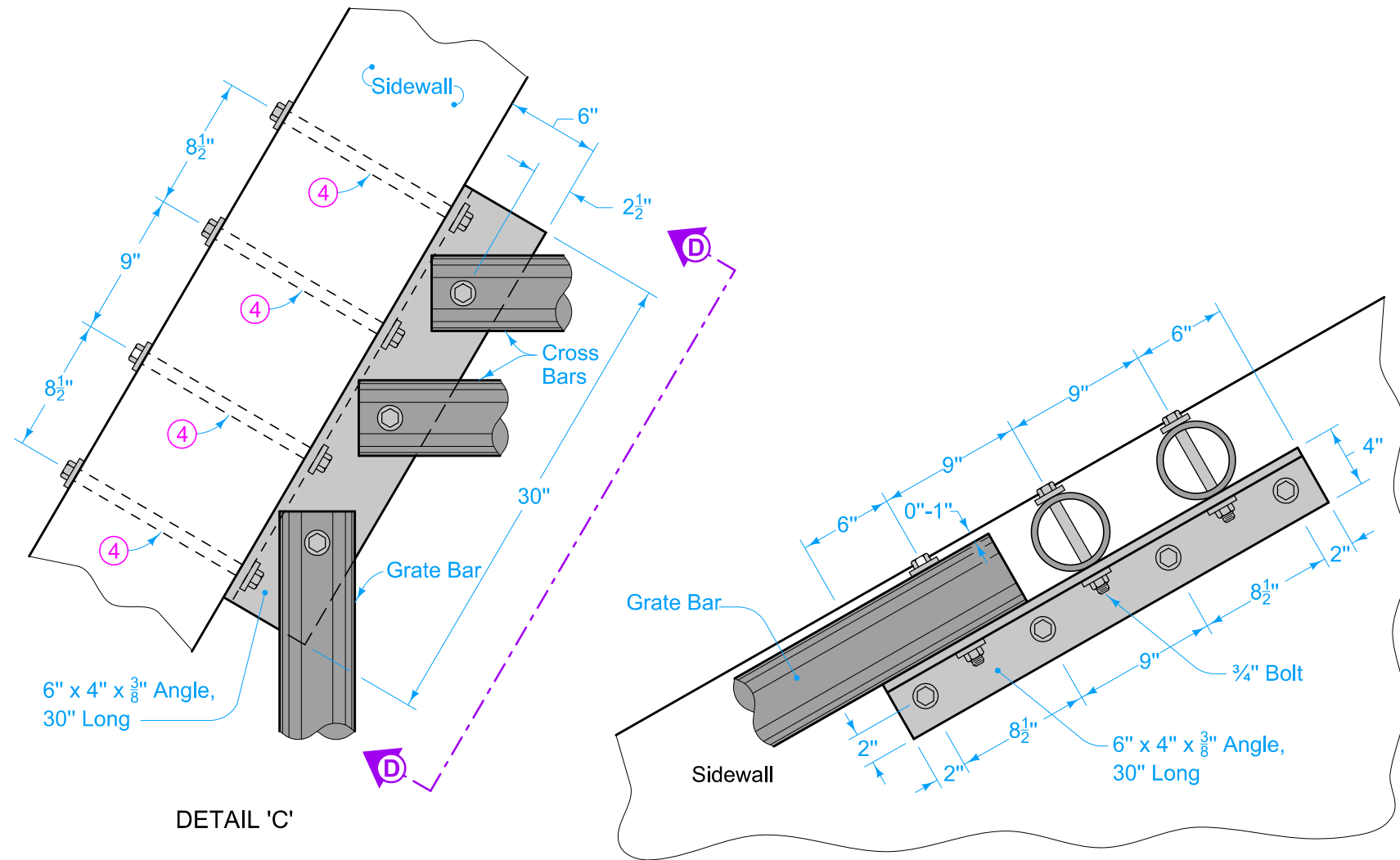

DETAIL 'D'

SECTION D-D

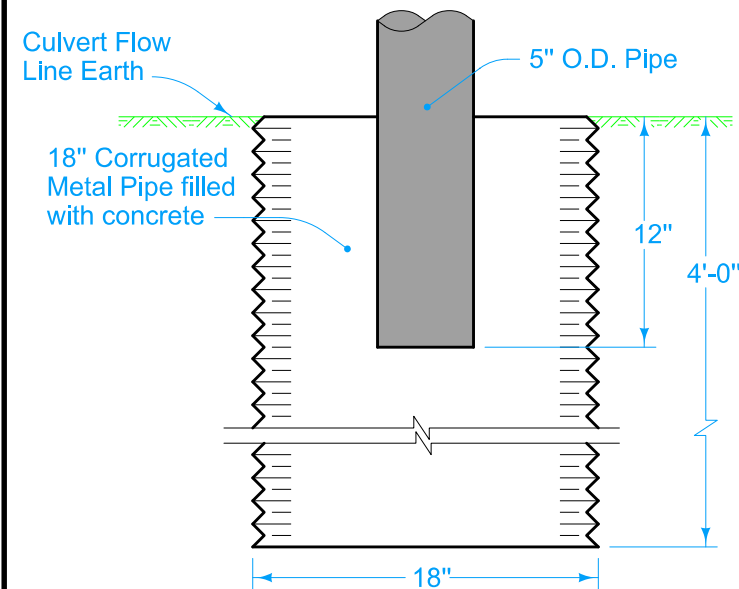

BOTTOM SUPPORT ON EARTH

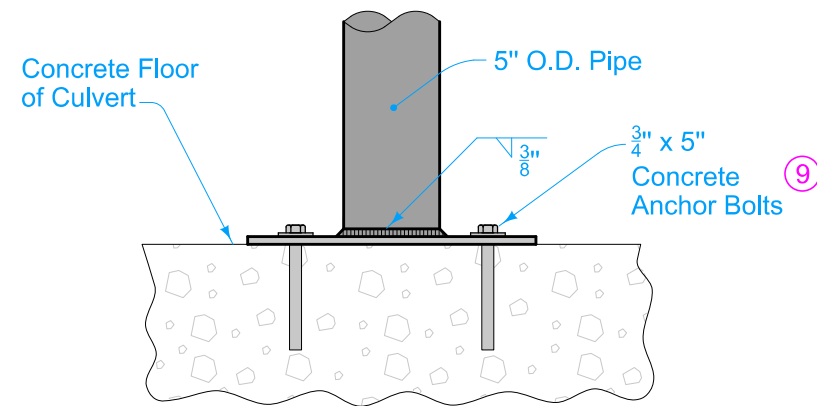

BOTTOM SUPPORT ON CULVERT FLOOR

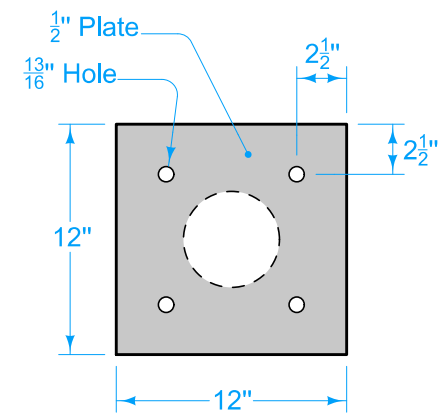

BOTTOM SUPPORT PLATE TOP VIEW

- ④ Drill $\frac{7}{8}$ inch diameter holes using equipment designed to cut through concrete and reinforcing steel.
- ⑨ Set approved anchor bolts using epoxy grout as described in Materials I.M. 453.08 for anchor bolts.

 STANDARD ROAD PLAN	<small>REVISION</small> 1 04-21-20	
	DR-503 <small>SHEET 4 of 4</small>	
<small>REVISIONS: Added Designer Info button.</small>		
 <small>APPROVED BY DESIGN METHODS ENGINEER</small>		
SAFETY GRATES FOR BOX CULVERTS		

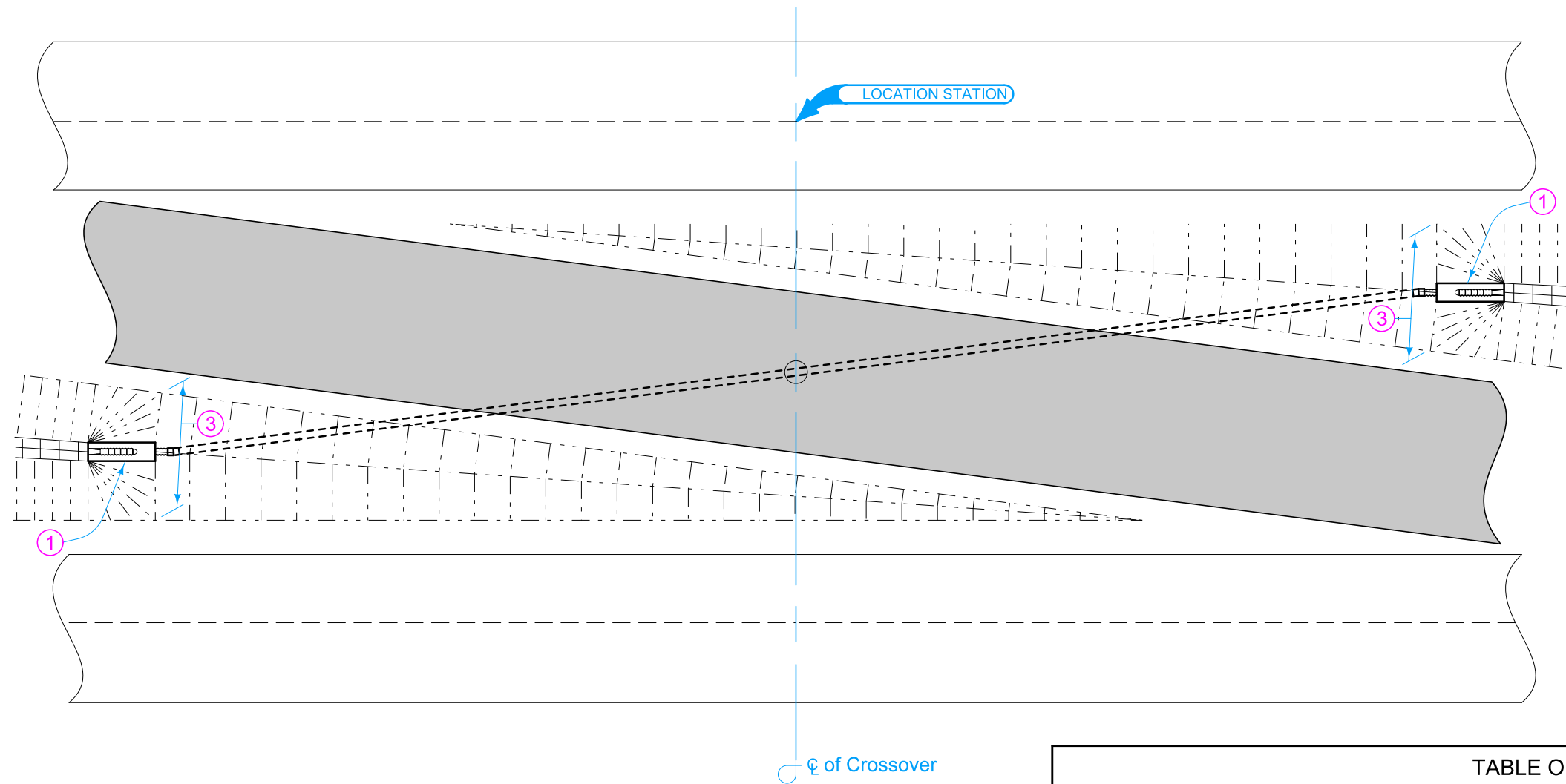

PLAN VIEW

TABLE OF QUANTITIES										
Standard Road Plan No.	PV-501	PV-502	PV-504	PV-505	PV-507	PV-508	PV-510	PV-511	PV-513	PV-514
Median Width	50.0'	50.0'	64.0'	64.0'	68.24'	68.24'	82.0'	82.0'	100.0'	100.0'
Crossover Pavement Width	16.0'	28.0'	16.0'	28.0'	16.0'	28.0'	16.0'	28.0'	16.0'	28.0'
Bid Item										
18" dia. Unclassified Entrance Pipe Culvert	250'	344'	112'	196'	82'	162'	56'	74'	148'	88'

- Possible Contract Items:
- Beveled Pipe and Guard
 - Culvert, Unclassified Entrance Pipe, 18" Dia.
 - Embankment-in-Place
 - Excavation, class 10, Roadway and Borrow
 - Special Backfill

Possible Tabulation:
112-8

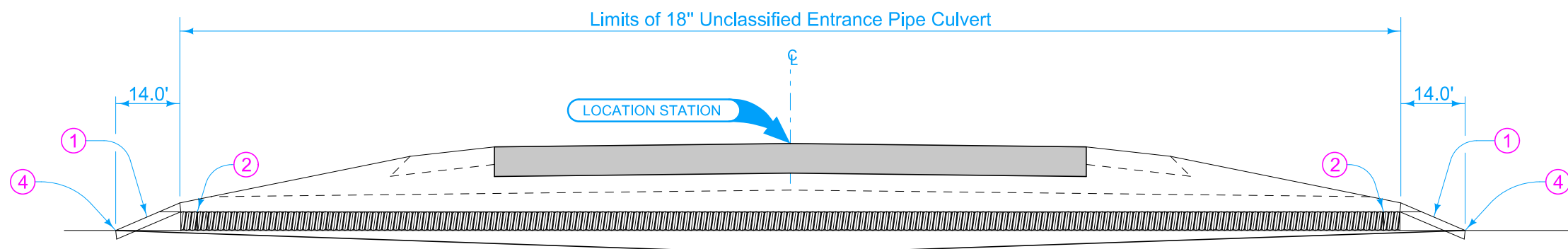

LONGITUDINAL SECTION AT PIPE CENTERLINE

	REVISION	
	New	04-21-20
STANDARD ROAD PLAN		DR-504
REVISIONS: New.		SHEET 1 of 1

APPROVED BY DESIGN METHODS ENGINEER

**DIAGONAL PLACED DRAIN FOR
MEDIAN CROSSOVERS**



℄ is C of roadway, dike, survey, or other as detailed on plans.

Skew angle is the angle which one end of the pipe is ahead (by stationing) of line perpendicular to the ℄. (Example: skew Rt. ahead 30 degrees)

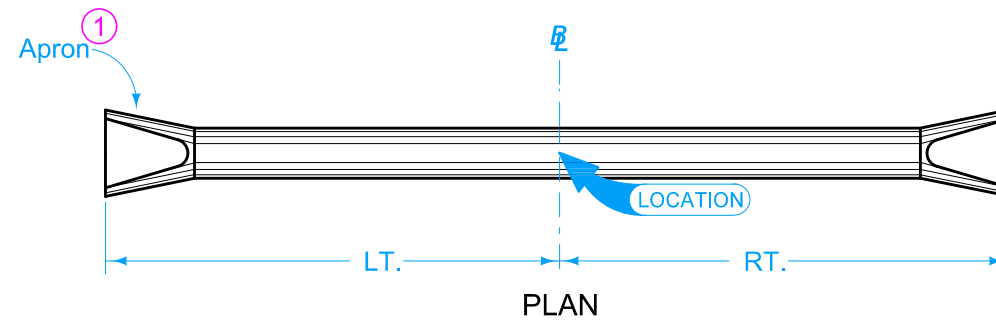
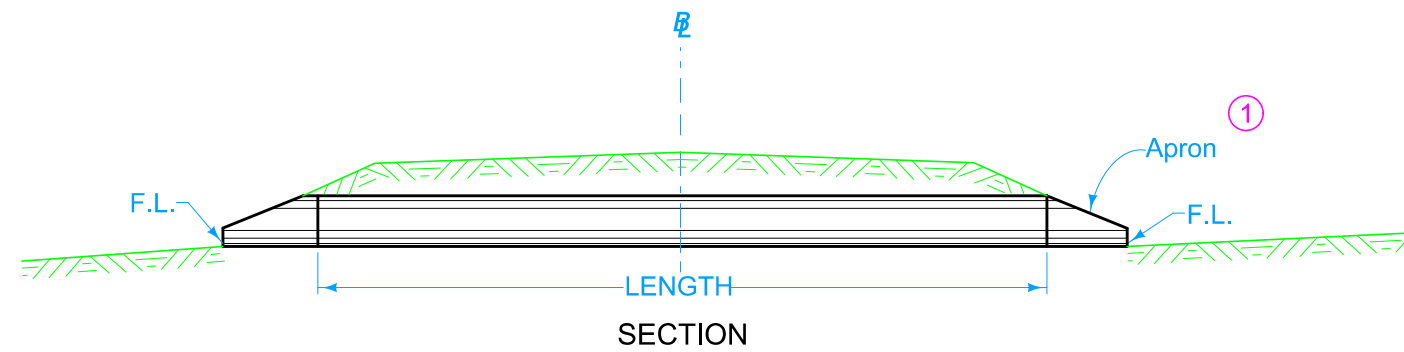
- ① Refer to the following:
 DR-201 for circular concrete.
 DR-202 for low clearance concrete.
 DR-203 for circular metal.
 DR-205 for circular concrete with end wall.
 DR-206 for low clearance concrete with end wall.



Possible Tabulation:
104-3

 STANDARD ROAD PLAN	REVISION	
	2	04-18-17
	DR-601	
SHEET 1 of 1		
REVISIONS: Modified note 1 to include references to additional apron types.		
 APPROVED BY DESIGN METHODS ENGINEER		
REINFORCED CONCRETE PIPE CULVERT		

\mathbb{E} is \mathbb{C} of roadway, dike, survey, or other as detailed on the plans.

Skew angle is the angle which one end of the pipe is ahead (by stationing) of a line perpendicular to the \mathbb{E} . (Example: skew Rt. ahead 30 degrees).

\mathbb{G} is the dimension to \mathbb{C} of Tee from outlet end of pipe. Either one or two Tees are required as specified.

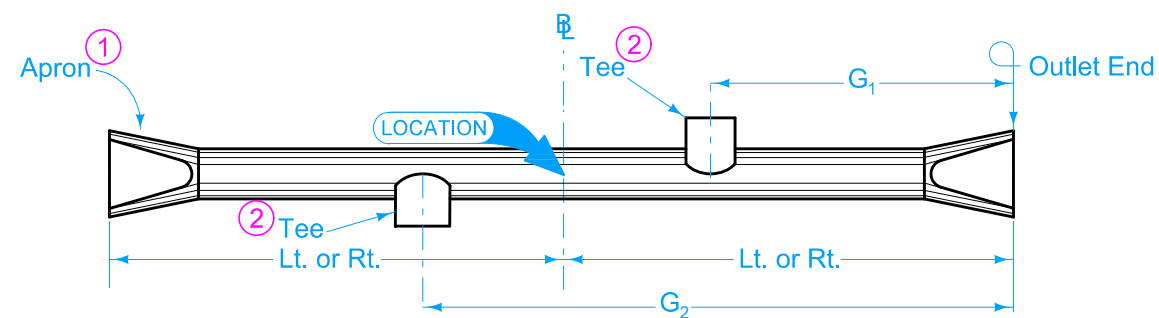
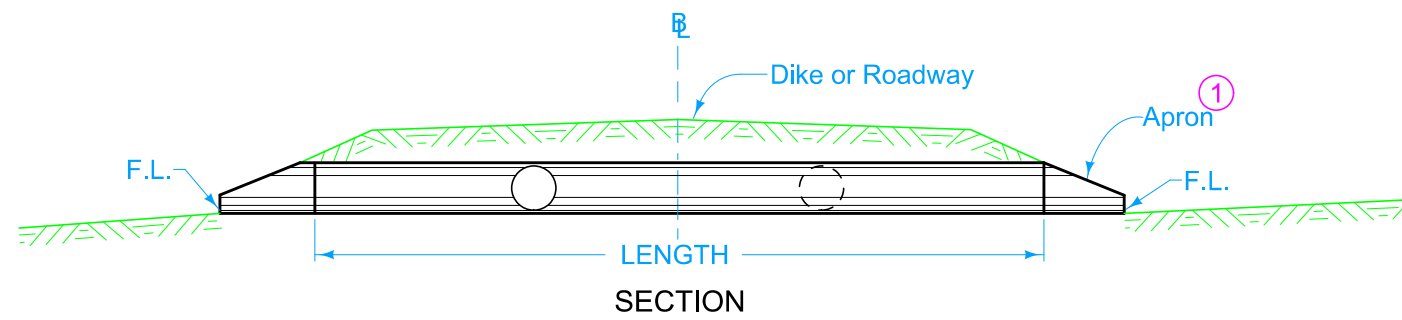



PLAN

REINFORCED CONCRETE PIPE CULVERT

- ① Refer to the following:
 DR-201 for circular concrete.
 DR-202 for low clearance concrete.
 DR-203 for circular metal.
 DR-205 for circular concrete with end wall.
 DR-206 for low clearance concrete with end wall.

- ② See DR-142.

Possible Tabulation:
104-3

 STANDARD ROAD PLAN	REVISION	
	1	04-18-17
DR-602		SHEET 1 of 1
REVISIONS: Modified note 1 to include references to additional apron types.		
 APPROVED BY DESIGN METHODS ENGINEER		
REINFORCED CONCRETE PIPE CULVERT WITH TEES		

\mathbb{R} is \mathbb{C} of roadway, dike, survey, or other; as detailed on plans.

- ① Refer to the following:
 DR-201 for circular concrete.
 DR-202 for low clearance concrete.
 DR-203 for circular metal.
 DR-205 for circular concrete with end wall.
 DR-206 for low clearance concrete with end wall.
- ② Bend may be accomplished by use of metal elbow, Pipe Adaptor (DR-122), Type "D" Section, or Concrete Elbow (DR-141) as specified.

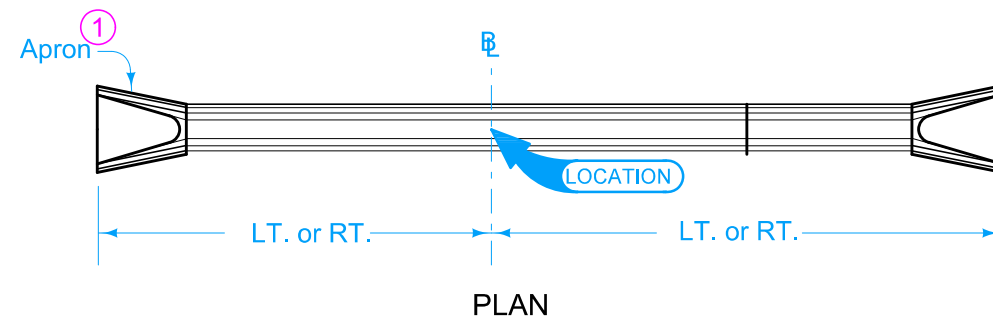
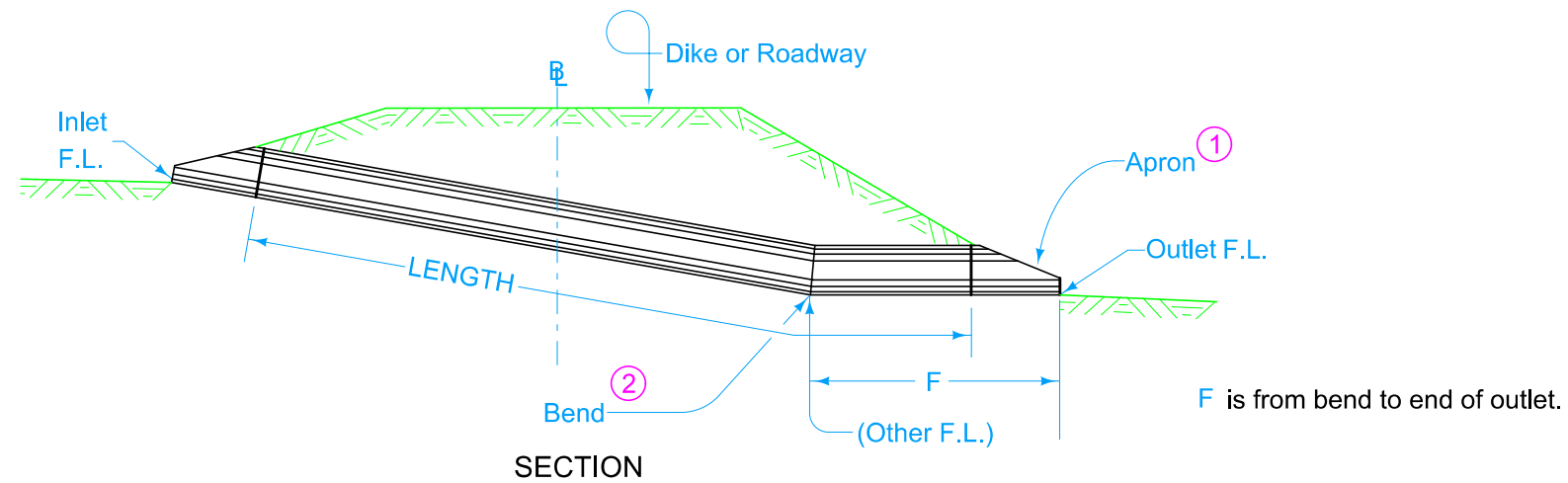

Possible Tabulation:
104-3

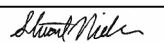
 STANDARD ROAD PLAN	REVISION	
	1	04-18-17
DR-611		SHEET 1 of 1
REVISIONS: Modified note 1 to include references to additional apron types.		
 APPROVED BY DESIGN METHODS ENGINEER		
REINFORCED CONCRETE PIPE CULVERT LETDOWN STRUCTURE		

\bar{E} is \bar{C} of roadway, dike, survey, or other as detailed on the plans.



Use when specified. This type of inlet assembly may be substituted for the inlet apron shown on drawings of standard type drainage structures.

- ① Refer to the following:
 DR-201 for circular concrete.
 DR-202 for low clearance concrete.
 DR-203 for circular metal.
 DR-205 for circular concrete with end wall.
 DR-206 for low clearance concrete with end wall.

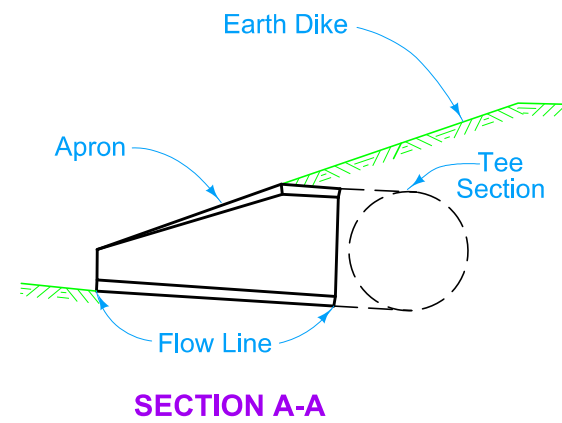
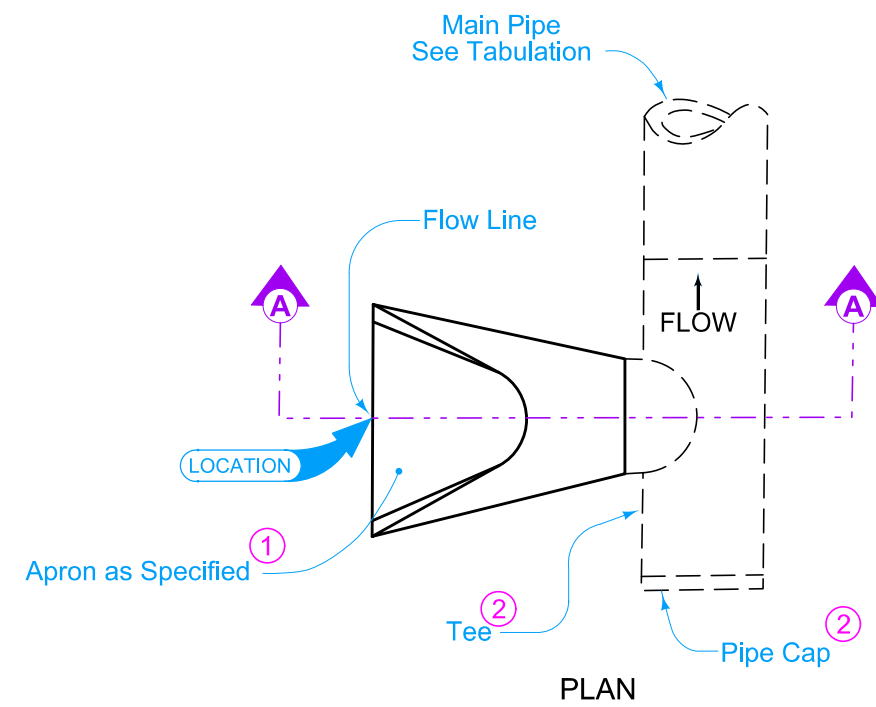
- ② See DR-142.



Possible Tabulation:
104-3



 STANDARD ROAD PLAN	REVISION	
	1	04-18-17
DR-612		SHEET 1 of 1
REVISIONS: Modified note 1 to include references to additional apron types.		
 APPROVED BY DESIGN METHODS ENGINEER		
APRON TEE INLET		

\mathbb{E} is \mathbb{C} of roadway, dike, survey, or other; as detailed on plans.

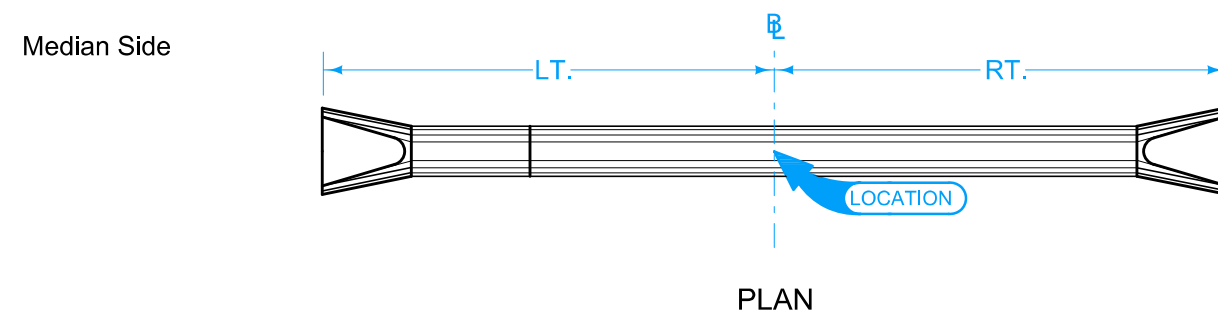
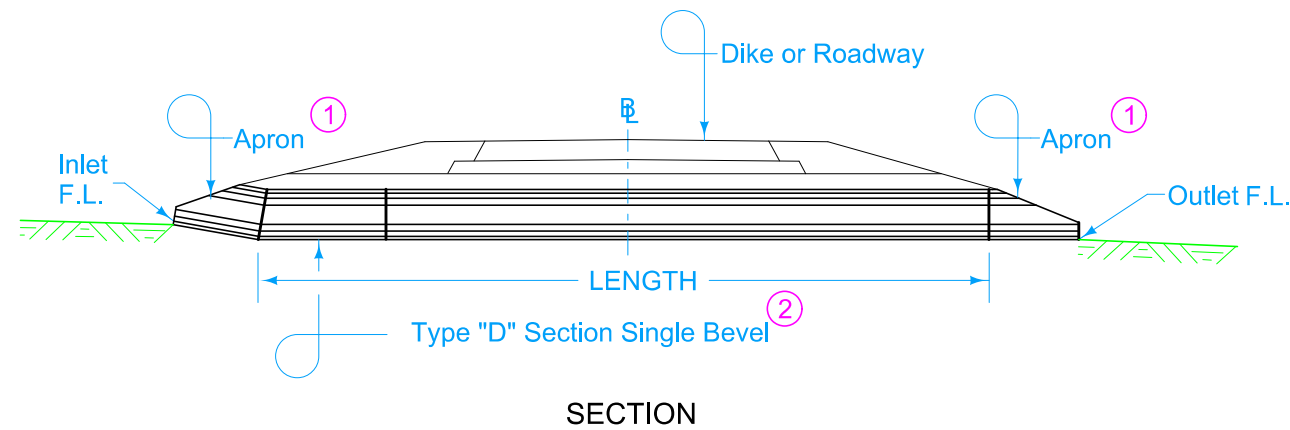
- ① Refer to the following:
 DR-201 for circular concrete.
 DR-202 for low clearance concrete.
 DR-205 for circular concrete with end wall.
 DR-206 for low clearance concrete with end wall.
- ② Type "D" Section with single bevel. See Standard Road Plan DR-141 for details.



Possible Tabulation:
104-3

 STANDARD ROAD PLAN	REVISION	
	New	04-17-18
DR-613		SHEET 1 of 1
REVISIONS: New.		
 <small>APPROVED BY DESIGN METHODS ENGINEER</small>		
CONCRETE PIPE WITH "D" SECTION		

\bar{E} is \bar{C} of roadway, dike, survey, or other as detailed on plans.

Extend on line of existing structure to Lt., Rt., or both as specified. Adaptors may be required, see DR-122.

- ① Refer to the following:
 DR-201 for circular concrete.
 DR-202 for low clearance concrete.
 DR-203 for circular metal.
 DR-205 for circular concrete with end wall.
 DR-206 for low clearance concrete with end wall.

- ② Optional Type "D" section only when specified in tabulation.

- ③ Existing structure.

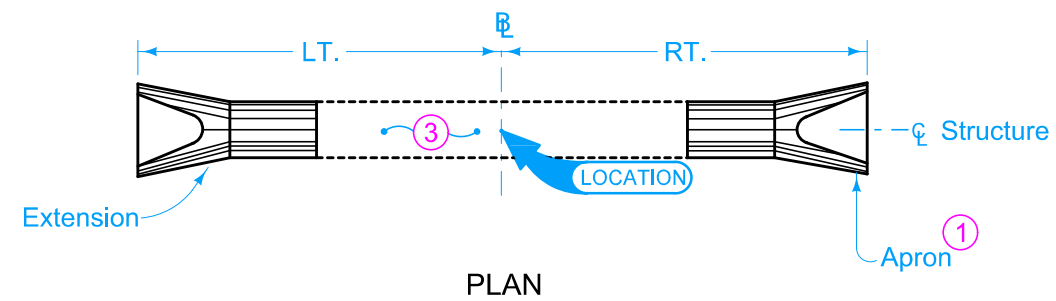
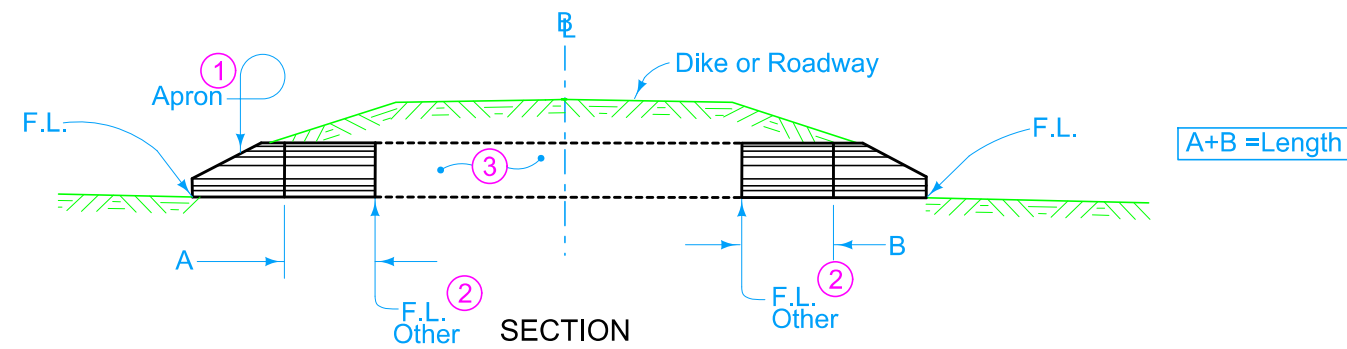

Possible Tabulation:
104-3

 STANDARD ROAD PLAN	REVISION	
	1	04-18-17
	DR-621	
SHEET 1 of 1		
REVISIONS: Modified note 1 to include references to additional apron types.		
<small>APPROVED BY DESIGN METHODS ENGINEER</small>		
PIPE EXTENSION		

DESIGNER INFORMATION

Φ is $\text{C}\phi$ of roadway, dike, survey, or other as detailed on plans.

Extend in the direction specified with skew measured from centerline of existing structure.

- ① Refer to the following:
 DR-201 for circular concrete.
 DR-202 for low clearance concrete.
 DR-203 for circular metal.
 DR-205 for circular concrete with end wall.
 DR-206 for low clearance concrete with end wall.

- ② Existing structure.

- ③ Dimension Rt. or Lt. is measured at $\text{C}\phi$ of pipe along laying length.

- ④ Bend may be accomplished by use of metal elbow, Adapter (DR-122), Type "D" Section, or Concrete Elbow (DR-141) as specified.

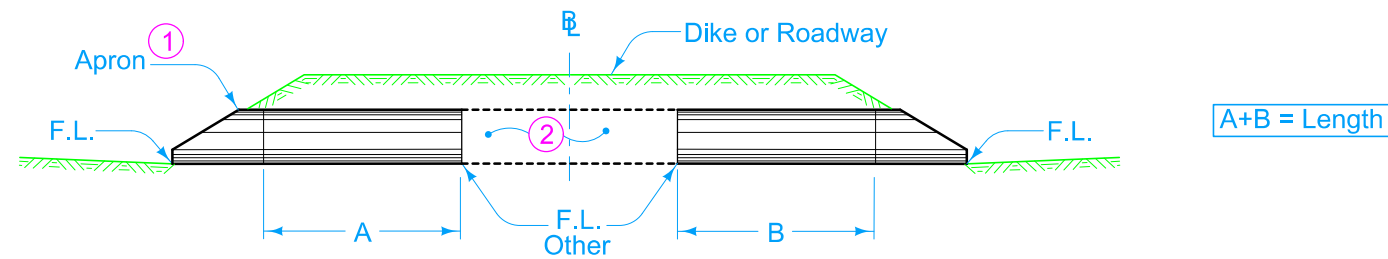

SECTION

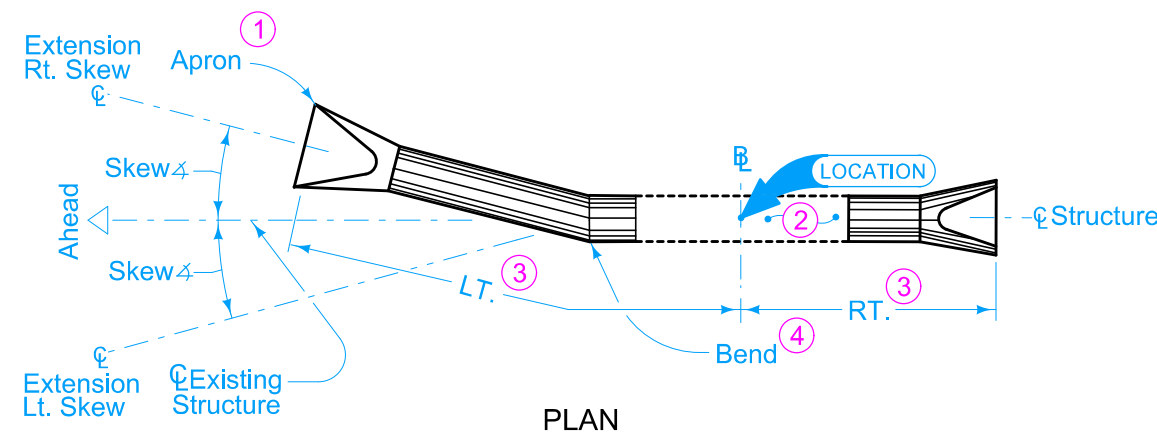

PLAN

Possible Tabulation:
104-3

	REVISION	
	2	10-17-17
STANDARD ROAD PLAN		DR-622
		SHEET 1 of 1
REVISIONS: Added Designer Info button.		
APPROVED BY DESIGN METHODS ENGINEER		
PIPE EXTENSION HORIZONTAL BEND ONE OR BOTH ENDS		

Φ is C of roadway, dike, survey, or other as detailed on plans.

Extend on line of existing structure to Lt., Rt., or both as specified. Adaptors may be required, see DR-122.

- ① Refer to the following:
 DR-201 for circular concrete.
 DR-202 for low clearance concrete.
 DR-203 for circular metal.
 DR-204 for arch metal.
 DR-205 for circular concrete with end wall.
 DR-206 for low clearance concrete with end wall.

- ② Optional Type "D" section only when specified in tabulation.

- ③ Existing structure.

- ④ See DR-122.

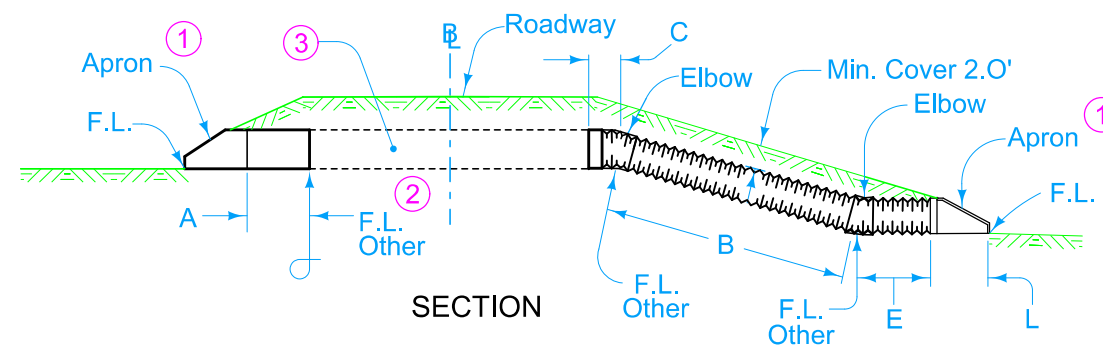

A = Concrete Pipe Length
 B+C+E = Corr. Pipe Length

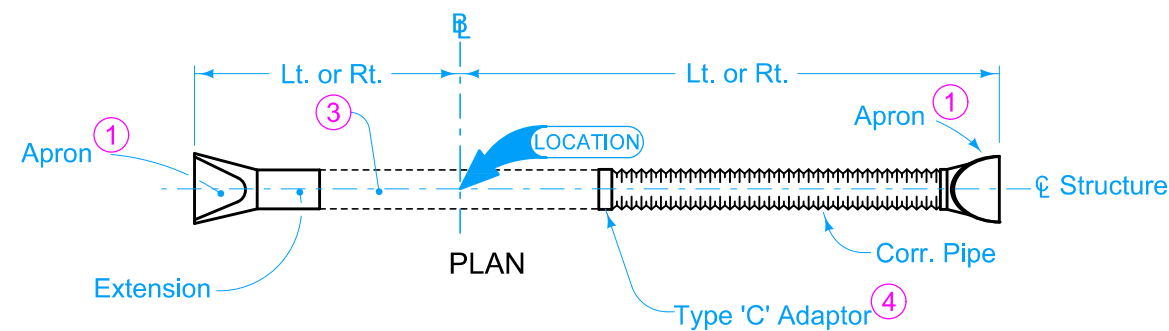

Possible Tabulation:
 104-3

	REVISION	
	1	04-18-17
STANDARD ROAD PLAN		DR-625
		SHEET 1 of 1

REVISIONS: Modified note 1 to include references to additional apron types.

Shawn Miller
 APPROVED BY DESIGN METHODS ENGINEER

**PIPE EXTENSION
 LETDOWN STRUCTURE
 WITH METAL APRON**

Extend on line of existing structure to Lt., Rt. or both as specified. Adapters may be required, see DR-122.

Optional Type "D" section or elbow for vertical drop only when specified in tabulation.

- ① Refer to the following and specify if inlet or outlet:
 DR-201 for circular concrete.
 DR-202 for low clearance concrete.
 DR-205 for circular concrete with end wall.
 DR-206 for low clearance concrete with end wall.

② Existing structure.

③ If less than 12 inch cover over pipe in median, install median pipe and dike.

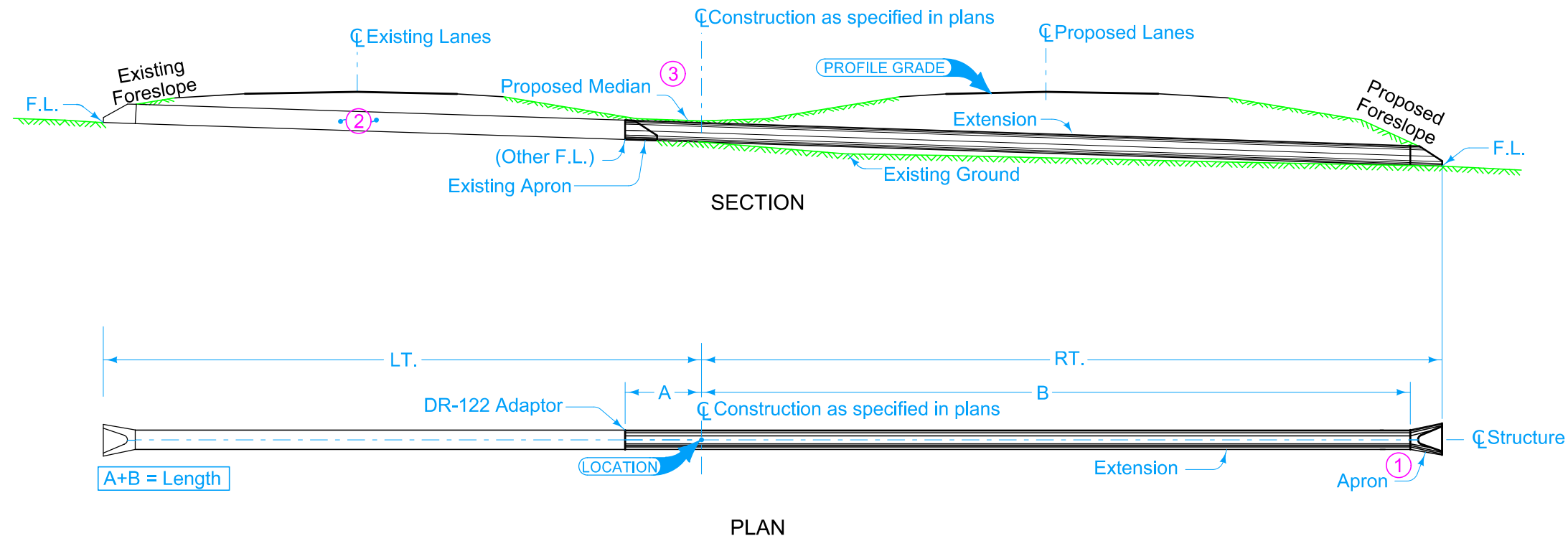

Possible Tabulation:
104-3

 STANDARD ROAD PLAN	REVISION	
	2	10-15-19
DR-626		SHEET 1 of 1
REVISIONS: Changed RF-2 Adapter to DR-122 Adapter.		

APPROVED BY DESIGN METHODS ENGINEER

PIPE EXTENSION - ADDING LANES

Extend in the direction specified with skew measured from centerline of existing structure. Dimension Rt. or Lt. is measured at CL of pipe along laying length.

- ① Refer to the following and specify if inlet or outlet:
 DR-201 for circular concrete.
 DR-202 for low clearance concrete.
 DR-205 for circular concrete with end wall.
 DR-206 for low clearance concrete with end wall.

② Existing structure.

③ If less than 12 inch cover over pipe in median, install median pipe and dike.

④ Bend may be accomplished by use of Adaptor (DR-122), Type "D" Section, or Concrete Elbow (DR-141) as specified.

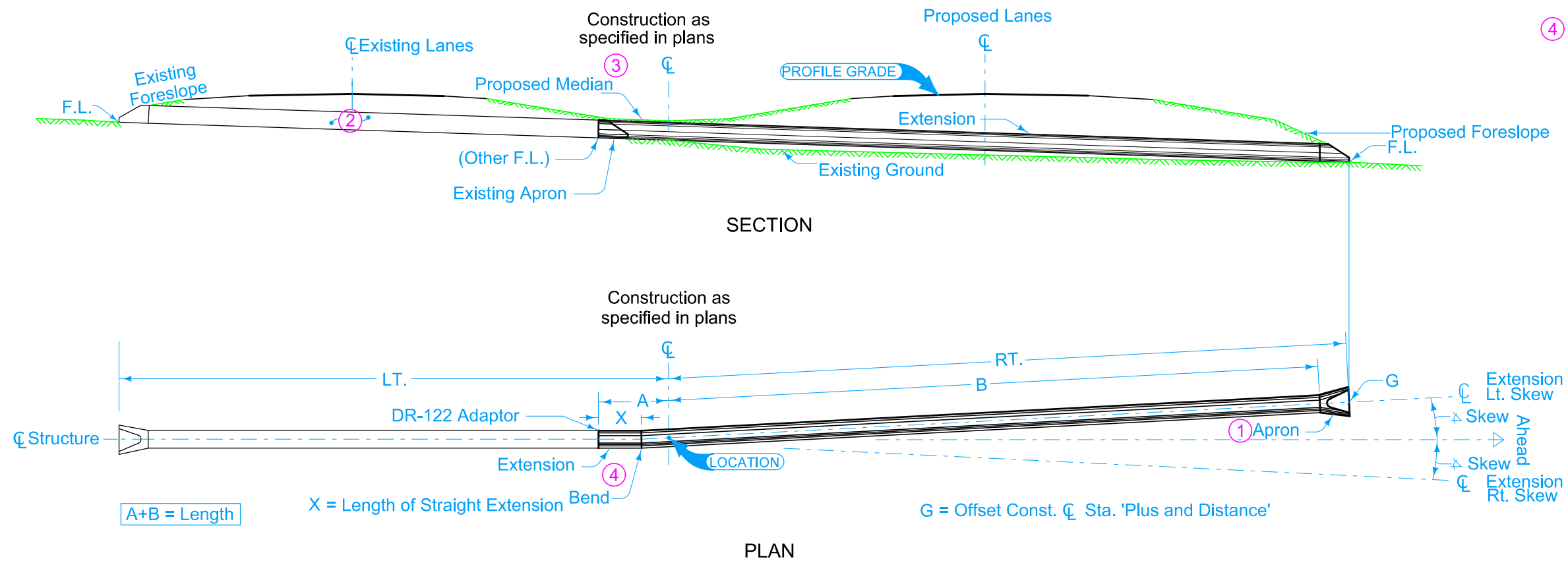

Possible Tabulation:
104-3

	REVISION	
	2	10-15-19
STANDARD ROAD PLAN		DR-627
REVISIONS: Changed RF-2 Adaptor to DR-122 Adaptor.		SHEET 1 of 1
 APPROVED BY DESIGN METHODS ENGINEER		
PIPE EXTENSION HORIZONTAL BEND - ADDING LANES		

Extend in the direction specified with skew measured from centerline of existing structure. Dimension Rt. or Lt. is measured at ϕ of pipe along laying length.

- ① Refer to the following and specify if inlet or outlet:
 DR-201 for circular concrete.
 DR-202 for low clearance concrete.
 DR-205 for circular concrete with end wall.
 DR-206 for low clearance concrete with end wall.
- ② Existing structure.
- ③ If less than 12 inch cover over pipe in median, install median pipe and dike.
- ④ Bend may be accomplished by use of Adaptor (DR-122), Type "D" Section, or Concrete Elbow (DR-141) as specified.

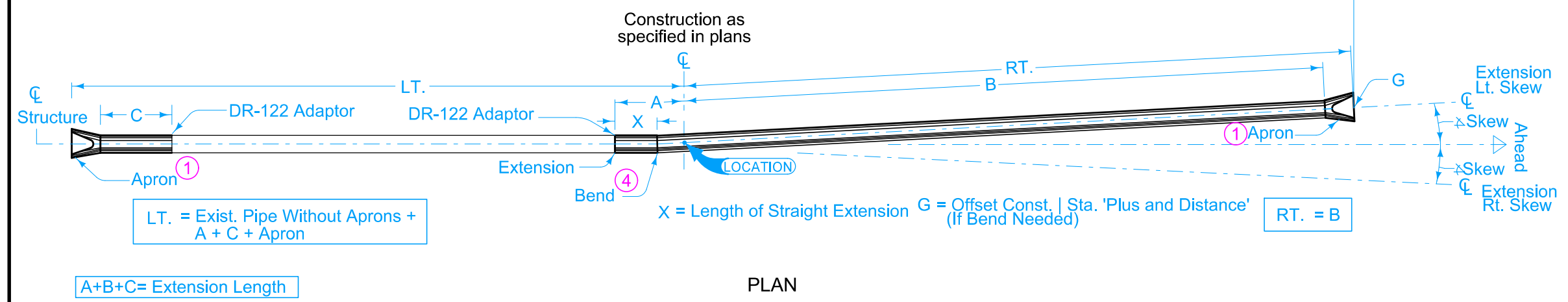
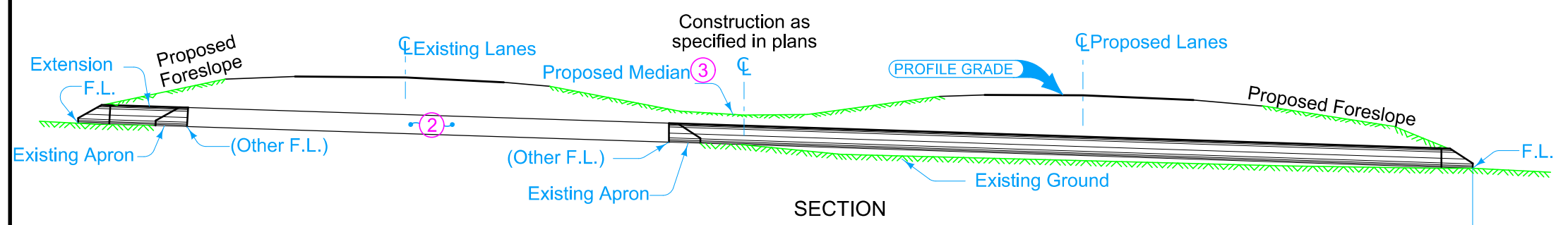

LT. = Exist. Pipe Without Aprons + A + C + Apron

A+B+C= Extension Length

X = Length of Straight Extension G = Offset Const. | Sta. 'Plus and Distance' (If Bend Needed) RT. = B

Possible Tabulation:
104-3

	REVISION	
	2	10-15-19
STANDARD ROAD PLAN		DR-628
		SHEET 1 of 1
REVISIONS: Changed RF-2 Adaptor to DR-122 Adaptor.		
APPROVED BY DESIGN METHODS ENGINEER		
PIPE EXTENSION BOTH ENDS HORIZONTAL BEND (OPTIONAL) - ADDING LANES		

If bend is required, extend in the direction specified with skew measured from centerline of existing structure. Dimension Rt. or Lt. is measured at C of pipe along laying length.

- ① Refer to the following:
DR-201 for circular concrete.
DR-202 for low clearance concrete.
DR-205 for circular concrete with end wall.
DR-206 for low clearance concrete with end wall.
- ② Existing structure.
- ③ If less than 12 inch cover over pipe in median, install median pipe and dike.
- ④ Optional Type "D" Section only when specified in the tabulation.
- ⑤ Install C-3 adaptor beyond proposed shoulder line. Flowline approximately 6 feet below shoulder elevation.
- ⑥ Bend may be accomplished by use of Type "D" Section or Concrete Elbow (DR-141) as specified.
- ⑦ Refer to the following:
DR-203 for the circular metal.
DR-204 for arch metal.

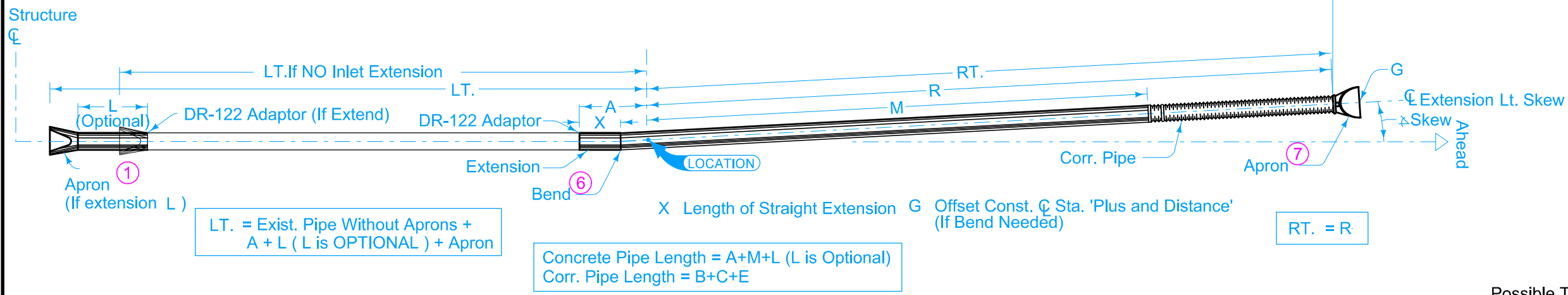
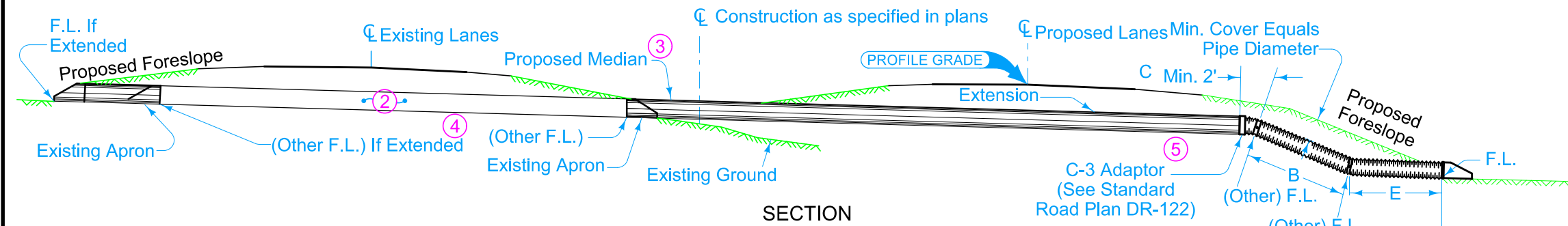

Possible Tabulation:
104-3

	REVISION	
	1	04-18-17
STANDARD ROAD PLAN		DR-629
		SHEET 1 of 1

REVISIONS: Modified notes 1 and 7 to include references to additional apron types.

Shawn Miller
APPROVED BY DESIGN METHODS ENGINEER



**PIPE EXTENSION LETDOWN STRUCTURE
HORIZONTAL BEND (OPTIONAL) -
ADDING LANES**

Standard type joint couplings are required. See Materials I.M. 441.

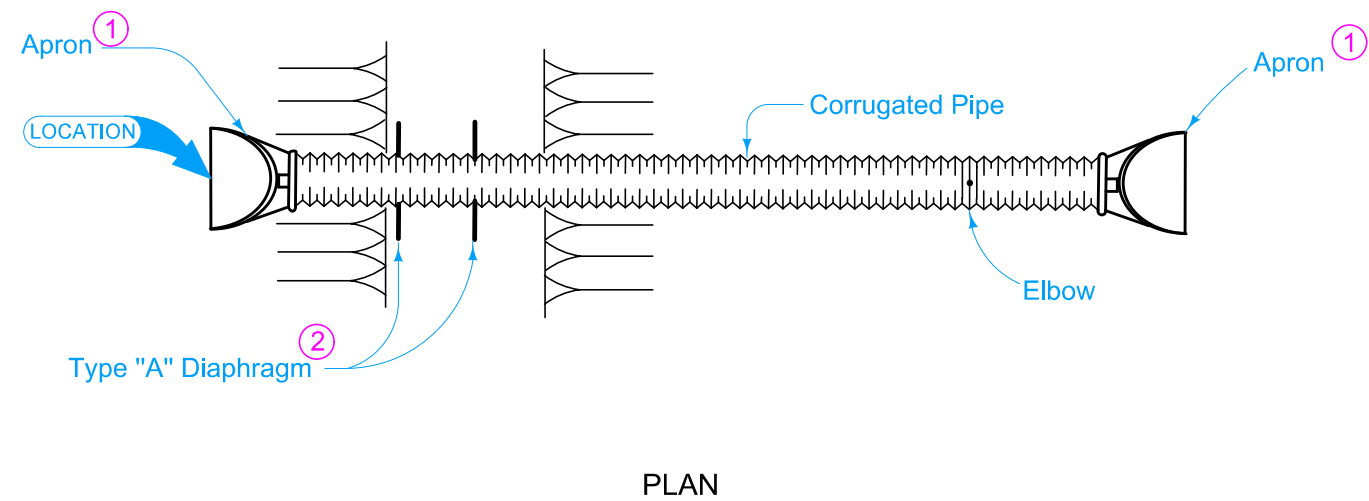
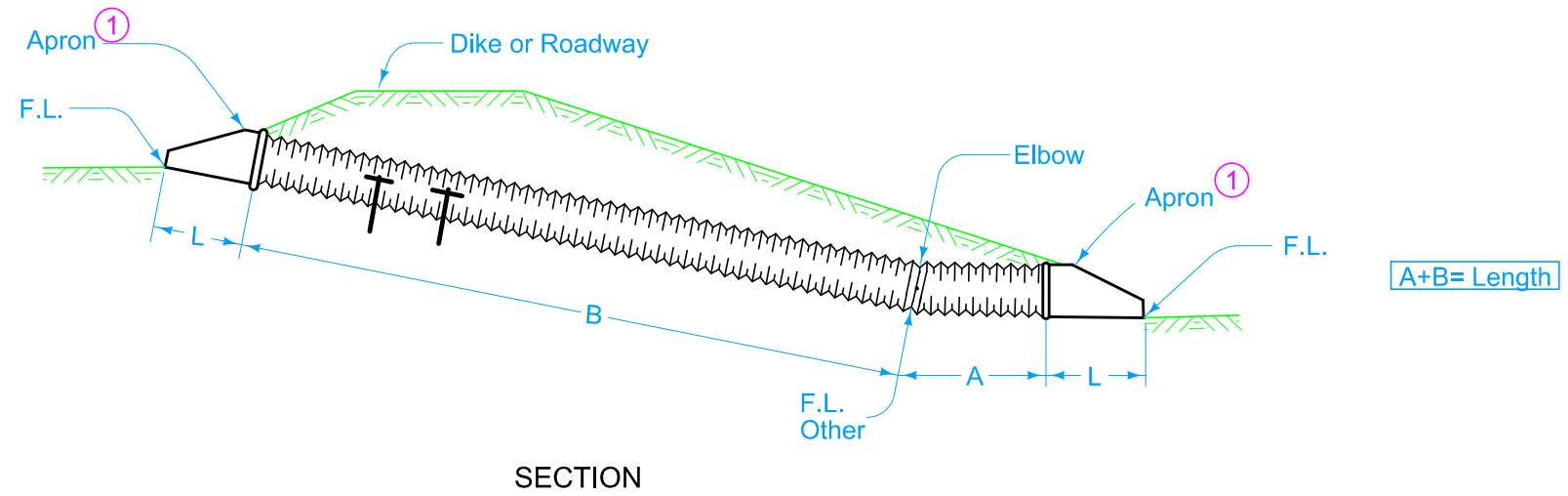
- ① Refer to the following:
DR-203 for the circular metal.
DR-204 for arch metal.
- ② See DR-501. If more than one diaphragm is specified, install 15 feet apart or as specified.



Possible Tabulation:
104-3

 STANDARD ROAD PLAN	REVISION	
	1	04-18-17
DR-631		SHEET 1 of 1
REVISIONS: Modified note 1 to include references to additional apron types.		
 APPROVED BY DESIGN METHODS ENGINEER		
CORRUGATED PIPE CULVERT LETDOWN STRUCTURE WITH SINGLE ELBOW		

Standard type joint couplings are required. See Materials I.M. 441.

Connection to outlet, if required, is incidental and will not be paid for separately.

① Refer to the following:
DR-203 for the circular metal.
DR-204 for arch metal.

② See DR-501. If more than one diaphragm is specified, install 15 feet apart or as specified.

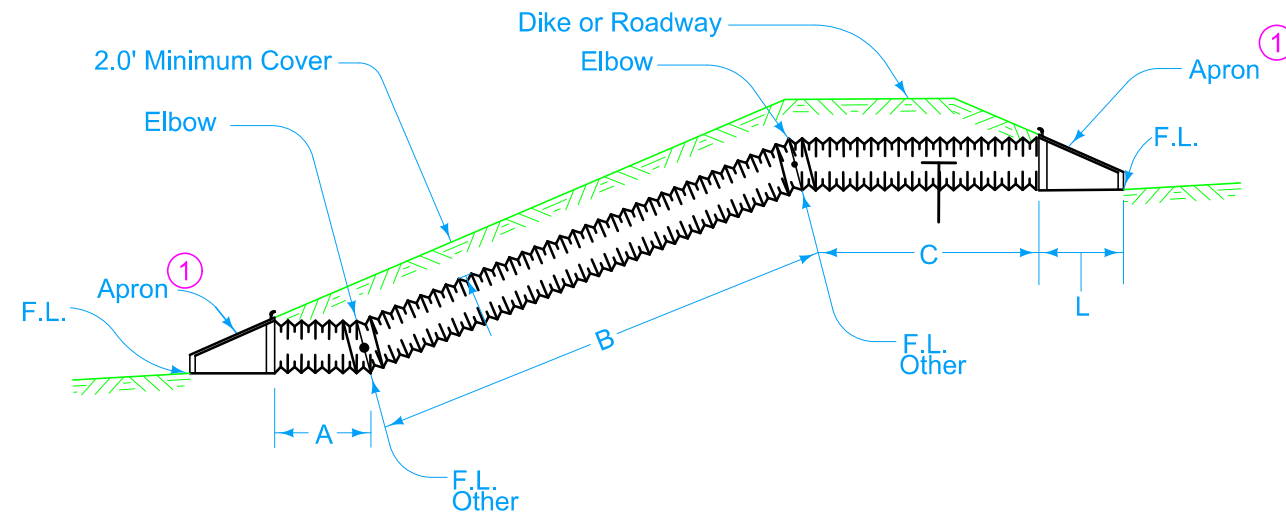

A+B+C = Pipe Length

SECTION

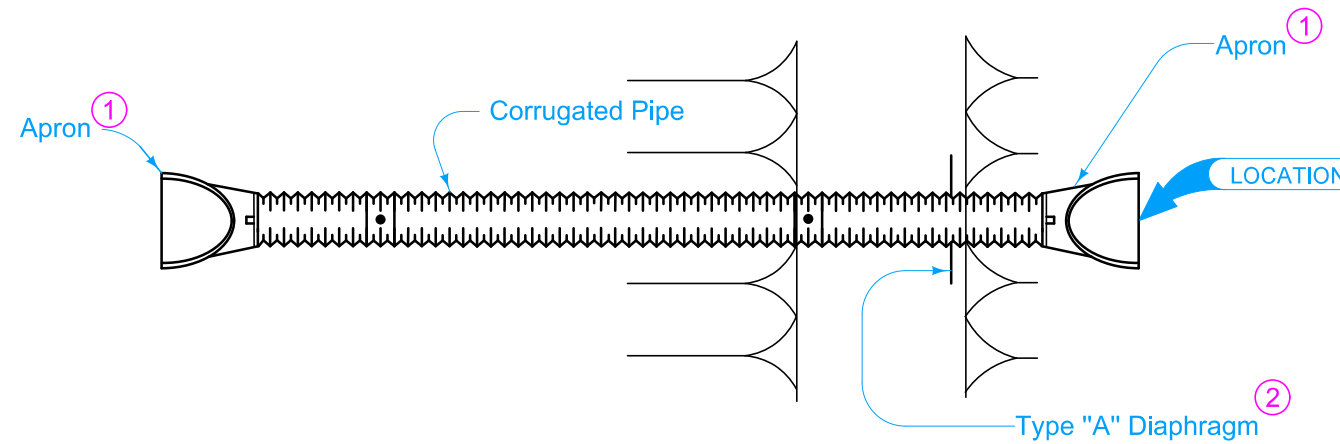

PLAN

Possible Tabulations:
104-3

	REVISION	
	1	04-18-17
STANDARD ROAD PLAN		DR-632
		SHEET 1 of 1
REVISIONS: Modified note 1 to include references to additional apron types.		
APPROVED BY DESIGN METHODS ENGINEER		
CORRUGATED PIPE CULVERT LETDOWN STRUCTURE WITH DOUBLE ELBOW		

\mathbb{E} is \mathbb{C} of roadway, dike survey or other as detailed on the plans.

Skew angle is the angle which one end of the pipe is ahead (by stationing) of a line perpendicular to the \mathbb{E} . (Example: Skew Rt. ahead 30 degrees)

Standard type joint couplings are required. See Materials I.M. 441.

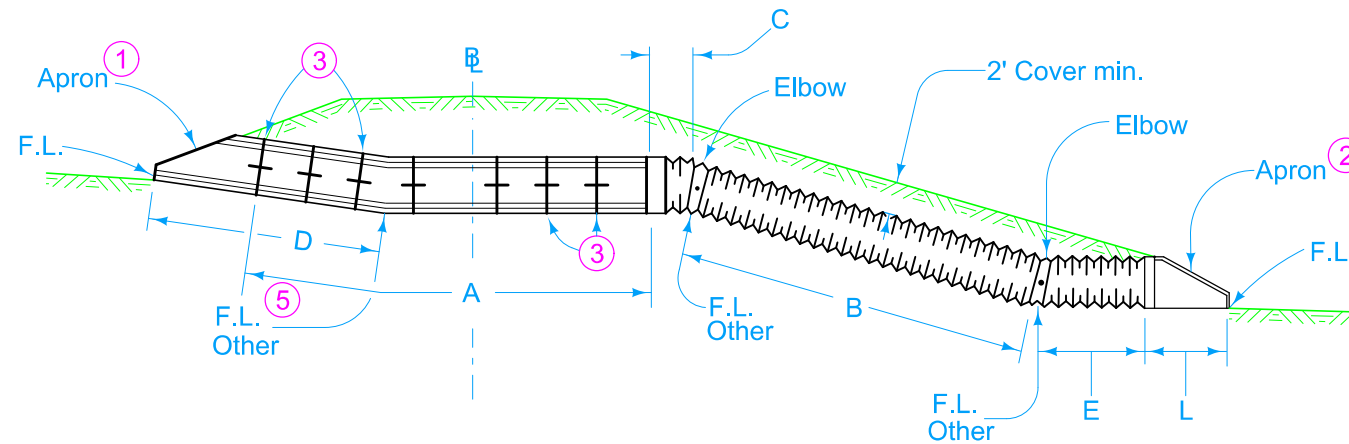

A = Concrete Pipe Length
B+C+E = C.M.P. or P.E.P. Length

SECTION

- ① Refer to the following:
DR-201 for circular concrete.
DR-202 for low clearance concrete.
DR-205 for circular concrete with end wall.
DR-206 for low clearance concrete with end wall.
- ② Refer to the following:
DR-203 for the circular metal.
DR-204 for arch metal.
- ③ See DR-121.
- ④ See DR-122.
- ⑤ Optional "D" section only when specified in the tabulation. Refer to DR-141.

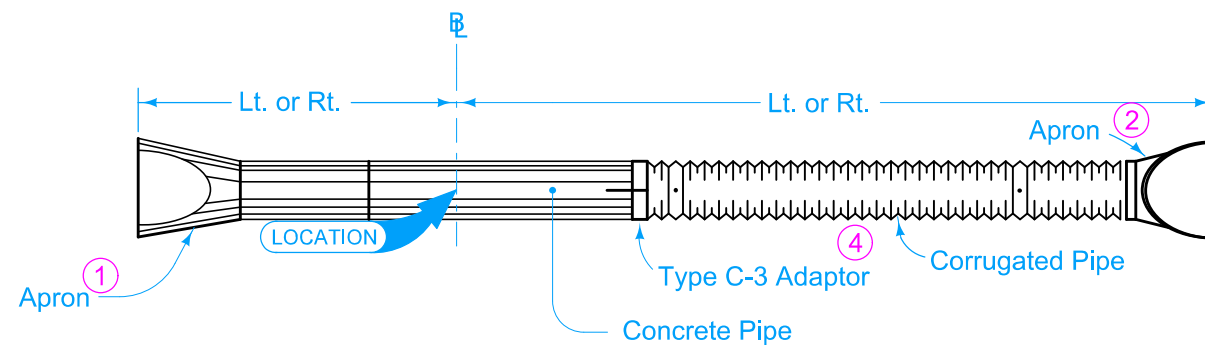

PLAN

Possible Tabulation:
104-3

	REVISION	
	3	04-21-20
STANDARD ROAD PLAN		DR-641
		SHEET 1 of 1
REVISIONS: Modified dimension line on Plan view.		
APPROVED BY DESIGN METHODS ENGINEER		
CONCRETE/CORRUGATED PIPE CULVERT LETDOWN STRUCTURE WITH METAL APRON		

\bar{C} is \bar{C} of roadway, dike, survey, or other as detailed on the plans.

Connection to outlet, if required, is incidental and will not be paid for separately

- ① Refer to the following:
 DR-201 for circular concrete.
 DR-202 for low clearance concrete.
 DR-203 for circular metal.
 DR-204 for arch metal (metal pipe only).
 DR-205 for circular concrete with end wall.
 DR-206 for low clearance concrete with end wall.

- ② Possible alignment if Type "D" Section or angle Tee is used.

- ③ Type "A" Diaphragm when specified, see DR-501.

- ④ Outlet structure.

- ⑤ Type "D" Section or angle Tee when specified.

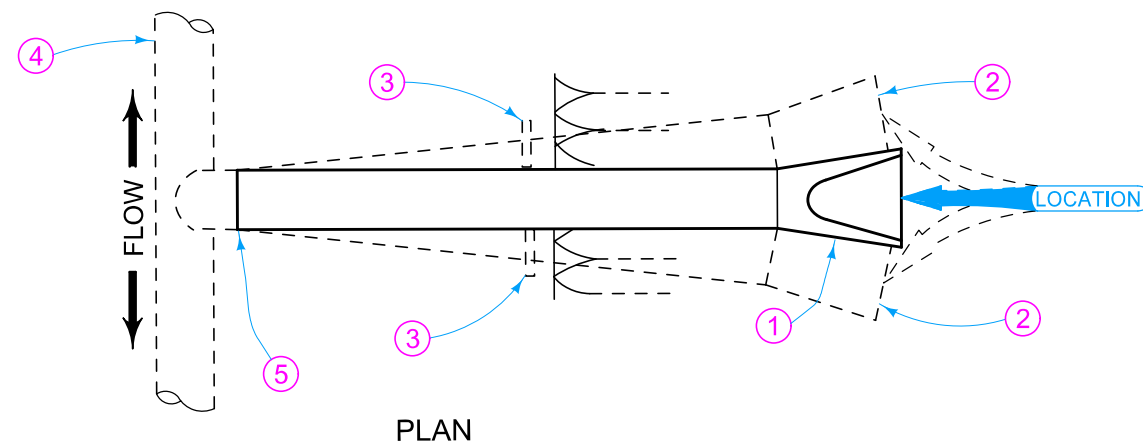
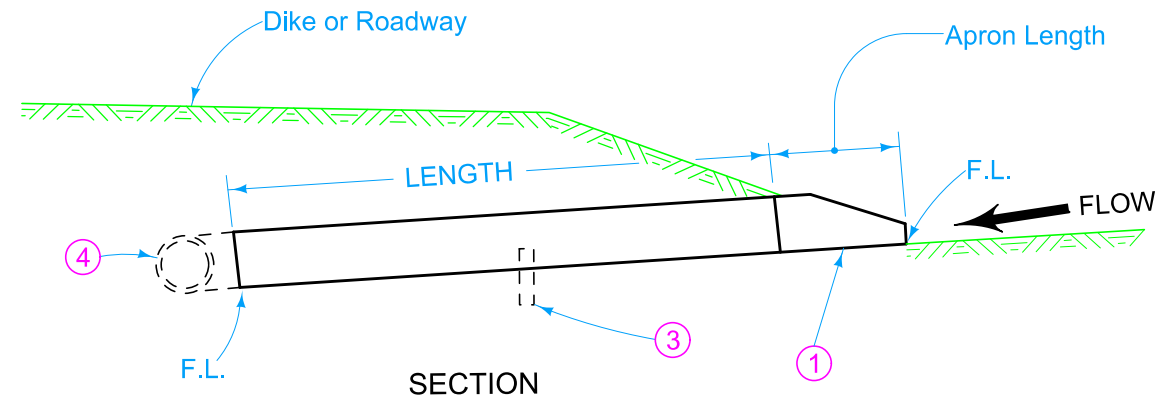

Possible Tabulation:
104-3

	REVISION	
	1	04-18-17
STANDARD ROAD PLAN		DR-642
		SHEET 1 of 1

REVISIONS: Modified note 1 to include references to additional apron types.

Shawn Miller
APPROVED BY DESIGN METHODS ENGINEER

APRON PIPE TEE INLET

℄ is C of roadway, dike, survey, or other as detailed on plans.

Skew angle is the angle which one end of the pipe is ahead (by stationing) of line perpendicular to the ℄. (Example: skew Rt. ahead 30 degrees)

- ① Refer to the following:
 DR-201 for circular concrete.
 DR-202 for low clearance concrete.
 DR-203 for circular metal.
 DR-204 for arch metal (metal pipe only).
 DR-205 for circular concrete with end wall.
 DR-206 for low clearance concrete with end wall.

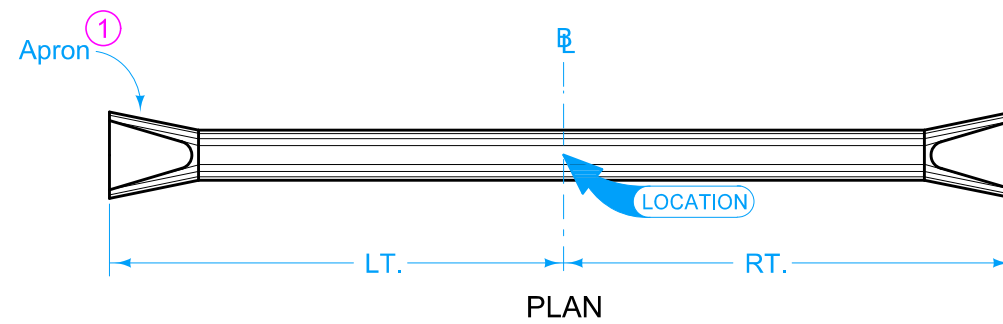
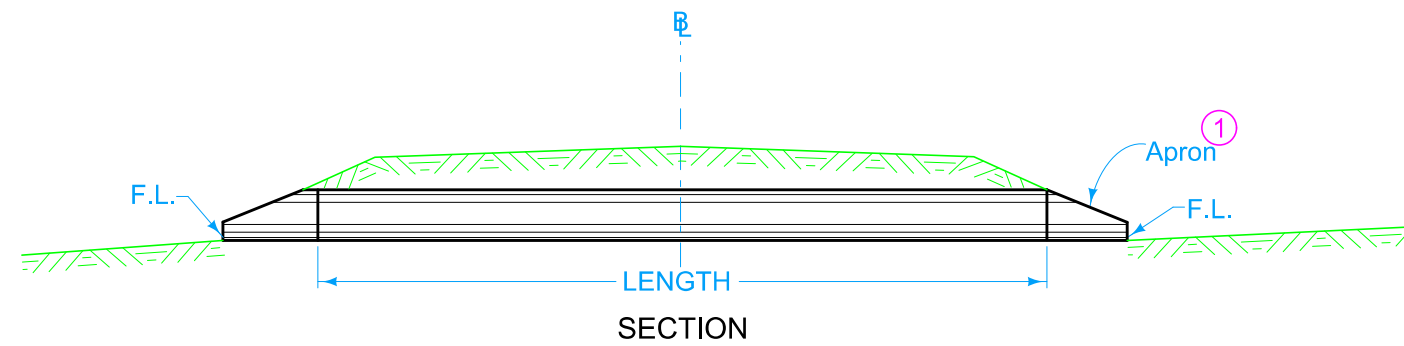

Possible Tabulation:
104-3

 STANDARD ROAD PLAN	REVISION	
	2	04-18-17
		DR-651
		SHEET 1 of 1

REVISIONS: Modified note 1 to include references to additional apron types.

Shawn Miller
 APPROVED BY DESIGN METHODS ENGINEER

UNCLASSIFIED PIPE CULVERT

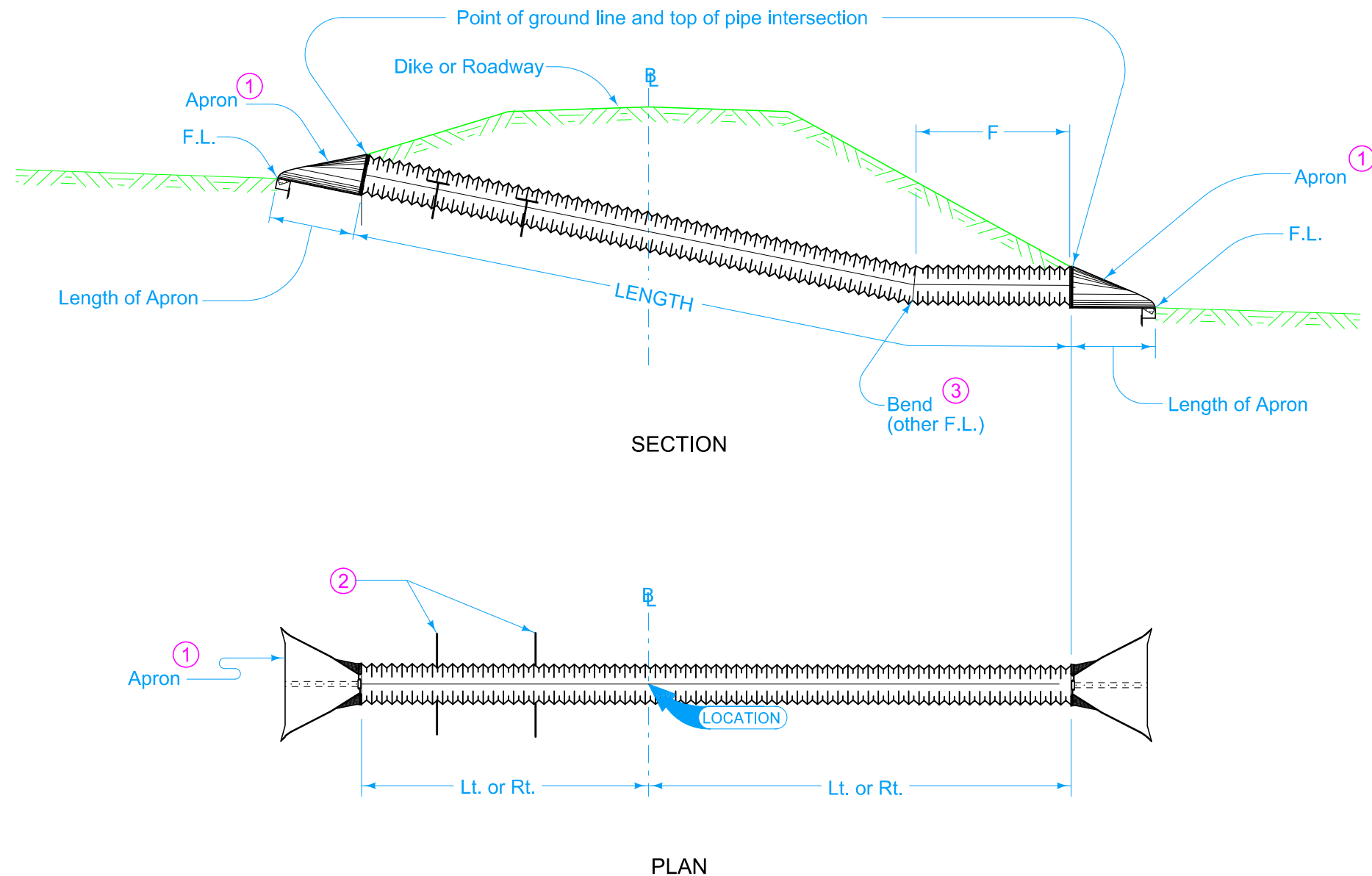

UNCLASSIFIED LETDOWN
STRUCTURE SINGLE ELBOW

\mathbb{B} is \mathbb{C} of roadway, dike, survey, or other as detailed on the plans.

Skew angle is the angle which one end of the pipe is ahead (by stationing) of a line perpendicular to the \mathbb{B} . (Example: skew Rt. ahead 30 degrees)

Standard type joint couplings are required. See Materials I.M. 441.

When the concrete option is used, use connected joints (DR-121) for the outer three joints.

- ① Refer to the following:
DR-201 for circular concrete.
DR-202 for low clearance concrete.
DR-203 for circular metal.
DR-204 for arch metal (metal pipe only).
DR-205 for circular concrete with end wall.
DR-206 for low clearance concrete with end wall.
- ② Type "A" Diaphragm, see DR-501. If more than one diaphragm is specified, install them 15 feet apart or as specified.
- ③ Bend may be accomplished by use of metal elbow, Pipe Adapter (DR-122), Type "D" Section, or Concrete Elbow (DR-141) as specified. Bend is considered incidental to the Length of pipe.

Possible Tabulation:
104-3

	REVISION	
	1	04-18-17
STANDARD ROAD PLAN		DR-652
		SHEET 1 of 1
REVISIONS: Modified note 1 to include references to additional apron types.		
APPROVED BY DESIGN METHODS ENGINEER		
UNCLASSIFIED LETDOWN STRUCTURE SINGLE ELBOW		

\mathbb{E} is \mathbb{C} of roadway, dike, survey, or other as detailed on the plans.

Skew angle is the angle which one end of the pipe is ahead (by stationing) of a line perpendicular to the \mathbb{E} . (Example: skew Rt. ahead 30 degrees)

Standard type joint couplings are required. See Materials I.M. 441.

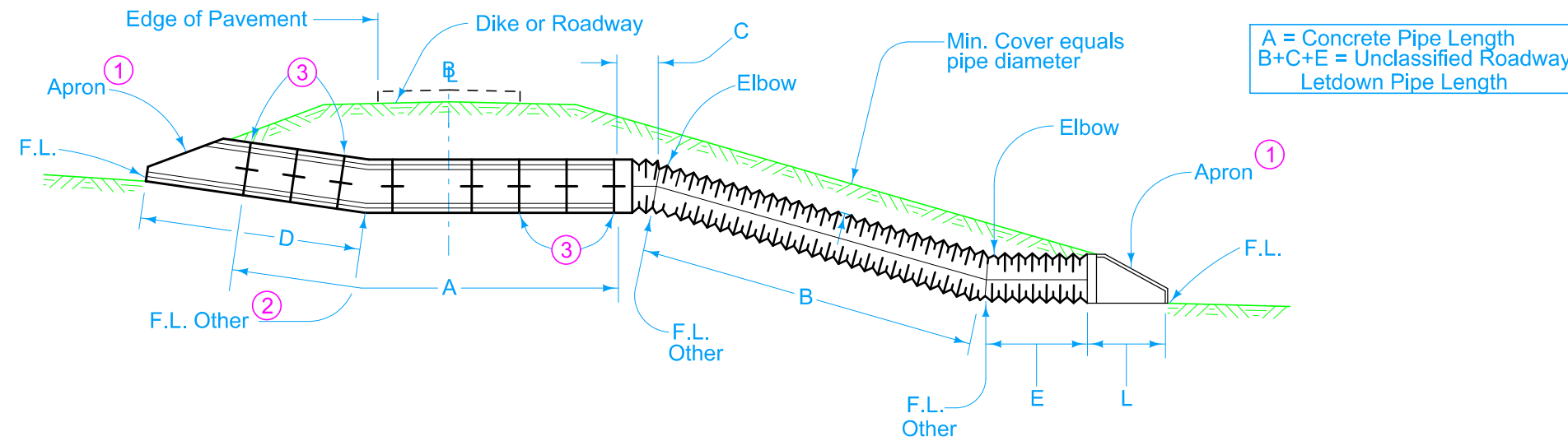

SECTION

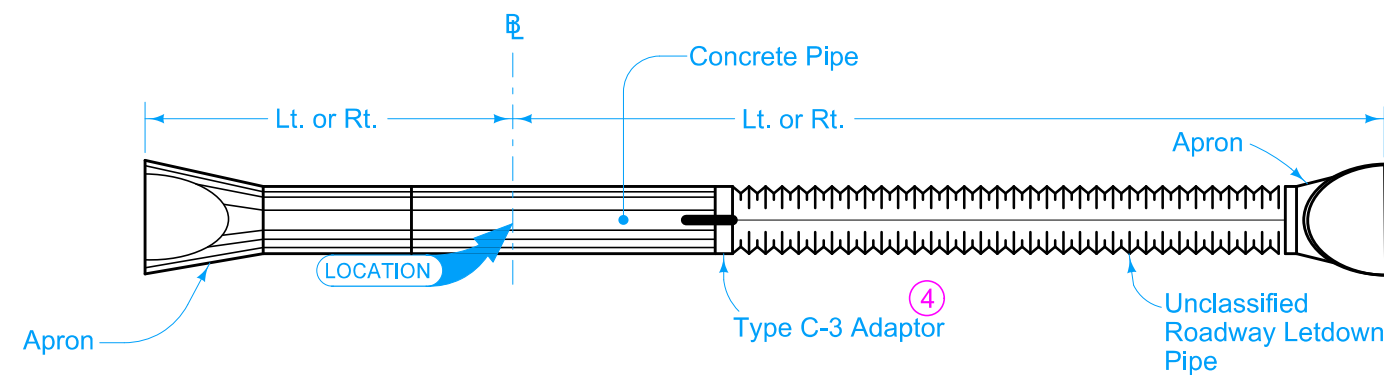

PLAN

- (1) Refer to the following:
 DR-201 for circular concrete.
 DR-202 for low clearance concrete.
 DR-203 for circular metal.
 DR-204 for arch metal (metal pipe only).
 DR-205 for circular concrete with end wall.
 DR-206 for low clearance concrete with end wall.
- (2) Optional "D" Section only when specified in tabulation.
- (3) See DR-121
- (4) See DR-122.

Possible Tabulation:
104-3

 STANDARD ROAD PLAN	REVISION	
	1	04-18-17
DR-653		SHEET 1 of 1

REVISIONS: Modified note 1 to include references to additional apron types. Added note 4.

Shawn Miller
APPROVED BY DESIGN METHODS ENGINEER

**UNCLASSIFIED ROADWAY LETDOWN PIPE
WITH METAL APRON**