

LRFD Pile Design Examples

Iowa DOT ~ Bridges and Structures Bureau ~ January 2025

Overview

These examples in customary U.S. (or English) units have been extracted and revised from the following publication:

Green, Donald, Kam W. Ng, Kenneth F. Dunker, Sri Sritharan, and Michael Nop. (2012). *Development of LRFD Procedures for Bridge Pile Foundations in Iowa - Volume IV: Design Guide and Track Examples*. IHRB Projects TR-573, TR-583, and TR-584. Institute for Transportation, Iowa State University, Ames, Iowa.

https://intrans.iastate.edu/app/uploads/2018/03/lrfd_vol_iv_final_w_cvr.pdf

In general the revisions are intended to relate the examples specifically to Iowa Department of Transportation (Iowa DOT), Bridges and Structures Bureau (OBS) policy in the Bridge Design Manual (BDM). A summary of the revisions from Volume IV follows.

- Move the contract length and resistance and the driving and construction control notes from Volume IV Articles 2.4.1-2.4.4 to BDM 13.8.2 listing (of Bridge Substructure CADD Notes), E718, E719, E818, and E819.
- Edit and move all of the appendices except Appendix E (Derivation of Equations...) from Volume IV to the Bridge Design Manual.
 - Appendix A to BDM 6.2.7 Nominal geotechnical resistances
 - Appendix B to BDM 6.2.8 Soil categories
 - Appendix C to BDM 6.2.9 Resistance factors
 - Appendix D to BDM 6.2.10 Cohesive soil setup
 - Appendix F to BDM 6.2.4.2 Pile length
 - Appendix G and H to various BDM articles
- Add structural design to Step 3 of all examples.

Because the Iowa DOT pile load tests used in calibration were conducted at a time when Standard Penetration Test hammers averaged about 60% efficiency and because the industry is moving toward a 60% standard, in the future the Iowa DOT intends to use N_{60} -values from Standard Penetration Tests. Until N_{60} -values are available the designer may use uncorrected N -values as shown in these examples. Uncorrected N -values from drilling rigs with modern automatic trip hammers may increase pile contract length slightly and reduce target driving resistance slightly but are not expected to have significant effects. (For typical design situations the Iowa DOT does not intend to use the overburden correction [AASHTO LRFD 10.4.6.2.4].)

Setup in cohesive soils may be used to reduce the end-of-drive (EOD) driving target for steel H-piles with WEAP construction control, as shown in several examples. However, at this time

setup should not be used with timber, steel pipe, or prestressed concrete piles or with Iowa DOT ENR Formula construction control.

There are eleven design examples, which are arranged in three tracks as listed in the table below. The tracks are intended to fit different design and construction practice in Iowa as noted.

Track 1: Standard Iowa DOT design and standard construction control with wave equation (WEAP) for ordinary projects on state, county, or city highways

Track 2: Standard Iowa DOT design and alternate construction control with the Iowa DOT ENR Formula (from the Iowa DOT Standard Specifications for Highway and Bridge Construction, Series 2012 Revised for 2013, 2501.03, M, 2) for ordinary projects on county or city highways (but not on state highways)

Track 3: Standard Iowa DOT design and alternate construction control with special methods for large and other special projects on state, county, or city highways

On the following page is a table summarizing characteristics of the examples, and following the table are brief descriptions of the examples.

Summary of characteristics of the track examples

Track Number	Pile Type	Example Number [Page]	Substructure Type	Soil Type	Special Considerations	Construction Controls	
						Driving Criteria	Planned Retap 3 Days after EOD
1	H-Pile	1 [1]	Integral Abutment	Cohesive	---	WEAP	No
		2 [18]	Pier	Mixed	Scour		
		3 [29]	Integral Abutment	Cohesive	Downdrag		
		4 [41]	Pier	Non-Cohesive	Uplift		
		5 [51]	Integral Abutment	Cohesive	End Bearing in Bedrock		
	Pipe Pile	6 [60]	Pile Bent	Non-Cohesive	Scour		
	Prestressed Concrete Pile	7 [69]	Pile Bent	Non-Cohesive	Scour		
2	H-Pile	1 [78]	Integral Abutment	Cohesive	---	Iowa DOT ENR Formula	
	Timber Pile	2 [92]	Integral Abutment	Non-Cohesive	---		
3	H-Pile	1 [102]	Integral Abutment	Cohesive	---	PDA/CAPWAP and WEAP	Yes
		2 [116]	Integral Abutment	Cohesive	Planned Retap	WEAP	

Abbreviations:

- CAPWAP, Case Pile Wave Analysis Program
- DOT, Department of Transportation
- ENR, Engineering News-Record
- EOD, end of drive
- PDA, Pile Driving Analyzer®
- WEAP, Wave Equation Analysis of Pile Driving (and successor programs such as GRLWEAP by GRL Engineers, Inc.), often referred to simply as “wave equation”

Each design example is a stand-alone document, but the first example in each track has the most extensive explanations and notes. A brief description of each design example is provided below.

Track 1, Example 1

As the first example in the Design Guide, this example provides detailed calculations that are not included in all other examples, such as:

- Selection of unit nominal resistance based on soil type and standard penetration test (SPT) N-value.
- Determination of setup factor for cohesive soil based on average SPT N-value.
- Determination of nominal driving resistance from blow count during construction.
- Determination of generalized soil category based on the ratio of pile penetration in cohesive and non-cohesive layers.
- Incorporation of setup into driving resistance estimation for cohesive soils.
- Discussion on pile retap 24 hours after EOD for piles with driving resistance at EOD less than the required nominal driving resistance.

Track 1, Example 2

This example illustrates that for a friction pile subject to scour, the contribution to side resistance from the soil above the scour interval should be neglected to estimate the nominal bearing resistance (Design Step 7), while this contribution should be included to estimate driving resistance (Design Step 8). The increase in the length of the friction pile to account for scour will result in additional driving resistance that must be accounted for when the piles are driven.

Track 1, Example 3

This example highlights the effects of downdrag on pile design: 1) the soil above the neutral plane does NOT contribute to side resistance; 2) downward relative movement of soil above the neutral plane exerts drag load to the pile. This example also demonstrates how prebored holes can be used to relieve part of the downdrag load.

Track 1, Example 4

This design example includes an uplift resistance calculation, in addition to the routine pile axial compression resistance calculation. Resistance factors for uplift are taken as 75% of the resistance factors for axial compression resistance.

Track 1, Example 5

This design example is for end bearing piles that are driven through cohesive soil and tipped out in rock. A resistance factor of 0.70 was used for end bearing in rock based on successful past practice with WEAP analysis and the general direction of Iowa LRFD pile testing and research. This design example presents the procedures to calculate pile resistance from a combination of side friction in soil and end bearing in rock. It also demonstrates how to consider the partial setup effect from the side resistance in cohesive soil.

Track 1, Example 6

This design example illustrates design of displacement pipe piles that develop frictional resistance in non-cohesive soil at a pile bent that is exposed to possible scour.

Track 1, Example 7

This design example is a companion to Example 6 and is for prestressed concrete friction piles that are driven in non-cohesive soil at a pile bent that is exposed to possible scour.

Track 2, Example 1

This design example demonstrates how to use the Iowa DOT ENR (Engineering News-Record) Formula to estimate nominal pile driving resistance from observed blow counts during pile driving. The only difference between this design example and Track 1, Example 1 is the construction control. It should be noted that the resistance factors used in this design example are lower than those in Track 1, Example 1, since more uncertainty is involved when using construction control based on the Iowa DOT ENR Formula instead of a wave equation analysis.

Track 2, Example 2

This design example is for timber piles that are driven in non-cohesive soil using the Iowa DOT ENR Formula for construction control.

Track 3, Example 1

This design example is basically the same as Track 1, Example 1, with additional construction control involving a pile driving analyzer® (PDA) and CAPWAP analyses. The purpose of this design example is to demonstrate that when more strict construction control is applied, fewer uncertainties are involved, since the pile resistance can be field-verified by PDA/CAPWAP tests. Therefore, higher resistance factors can be used; and this results in shorter pile length.

Track 3, Example 2

This design example is basically the same as Track 1, Example 1, with additional construction control involving pile retaps (or restrikes) at 3 days after EOD. It should be noted that the resistance factors with special consideration of pile setup are for 7-day retap. This design example demonstrates how to estimate the nominal driving resistance at 3 days after EOD using the setup factor chart. It also demonstrates that higher resistance factors can be used, when retap is planned, since the retap is used to verify the increase in geotechnical pile resistance as a result of pile setup.

In order to work through a design example the designer will need the AASHTO LRFD Specifications to determine the factored load and several sections from the Bridge Design Manual to determine resistance factors, resistances, and appropriate plan notes:

- 6.2 Piles
- 6.5 Abutments
- 6.6 Piers
- 13 CADD Notes

On the next page is a summary of the load factors, resistance factors, and resistances at the strength limit state and information sources for the four pile types that may be used by the Bridges and Structures Bureau. The Bureau most commonly uses H-piles.

Load factors, resistance factors, resistances at strength limit state and AASHTO and BDM information sources by pile type

Factor	Steel H-pile	Timber pile	Prestressed concrete pile	Concrete-filled pipe pile
Structural load factors, γ	AASHTO 3.4.1	AASHTO 3.4.1	AASHTO 3.4.1	AASHTO 3.4.1
Structural load factor for downdrag, γ_{DD}	BDM 6.2.4.3 $\gamma_{DD} = 1.0$	BDM 6.2.4.3 $\gamma_{DD} = 1.0$	BDM 6.2.4.3 $\gamma_{DD} = 1.0$	BDM 6.2.4.3 $\gamma_{DD} = 1.0$
Downdrag load, DD	BDM Table 6.2.7-2	BDM Table 6.2.7-2	BDM Table 6.2.7-2	BDM Table 6.2.7-2
Structural resistance factors, ϕ	AASHTO 6.5.4.2	AASHTO 8.5.2.2	AASHTO 5.5.4.2	AASHTO 6.5.4.2
Structural bearing resistance factor for pile bent, ϕ	BDM Table 6.6.4.2.1.1, $\phi = 0.70$		BDM Table 6.6.4.2.1.2, $\phi = 0.75$	BDM Table 6.6.4.2.1.3, $\phi = 0.80$
Structural bearing resistance, R_n	BDM 6.2.6.1 SRL-1, SRL-2, SRL-3, SRL-4	BDM 6.2.6.3 80 kips, 100 kips	AASHTO Section 5	AASHTO 6.9.5, 6.12.2.3
Structural bearing resistance for integral abutment, R_n	BDM Tables 6.5.1.1.1-1 and 6.5.1.1.1-2	BDM 6.2.6.3 64 kips		
Structural bearing resistance for pile bent, R_n	BDM Table 6.6.4.2.1.1 or P10L		BDM Table 6.6.4.2.1.2 or P10L	BDM Table 6.6.4.2.1.3 or P10L
Structural lateral resistance	BDM 6.2.6.1 18 kips	BDM 6.2.6.3 7 kips		
Geotechnical bearing resistance factor, ϕ	BDM Table 6.2.9-1	BDM Table 6.2.9-1	BDM Table 6.2.9-1	BDM Table 6.2.9-1
Geotechnical uplift resistance factor, ϕ	BDM Table 6.2.9-2	BDM Table 6.2.9-2	BDM Table 6.2.9-2	BDM Table 6.2.9-2
Geotechnical end resistance, R_n	BDM Table 6.2.7-1	BDM Table 6.2.7-1	BDM Table 6.2.7-1	BDM Table 6.2.7-1
Geotechnical friction resistance, R_n	BDM Table 6.2.7-2 and 6.2.7 discussion	BDM Table 6.2.7-2 and 6.2.7 discussion	BDM Table 6.2.7-2 and 6.2.7 discussion	BDM Table 6.2.7-2 and 6.2.7 discussion

Driving resistance factor, ϕ_{TAR}	BDM Table 6.2.9-3 Fig 6.2.10	BDM Table 6.2.9-3 0.35 or 0.40	BDM Table 6.2.9-3 Fig 6.2.10	BDM Table 6.2.9-3 Fig 6.2.10
CADD plan notes	BDM 13.8.2: E718, E719, E818, E819	BDM 13.8.2: E718, E719, E818, E819	BDM 13.8.2: E718, E719, E818, E819	BDM 13.8.2: E718, E719, E818, E819

Track 1, Example 1

Driven H-Pile in Cohesive Soil with Construction Control Based on Wave Equation and No Planned Retap

General design and construction steps to be modified for project conditions

Design Steps	
Step 1	Develop bridge situation plan (or TS&L, Type, Size, and Location). ⁽¹⁾
Step 2	Develop soils package, including soil borings and foundation recommendations. ⁽¹⁾
Step 3	Determine pile layout, pile loads including downdrag, and other design requirements. ⁽¹⁾ This step includes structural checks.
Step 4	Estimate nominal geotechnical resistance for friction and end bearing.
Step 5	Select resistance factor(s) to estimate pile length based on the soil profile and construction control.
Step 6	Calculate required nominal pile resistance, R_n .
Step 7	Estimate contract pile length, L , considering downdrag, scour, pile uplift, lateral loading, and unbraced length, if applicable.
Step 8	Estimate target nominal pile driving resistance, R_{ndr-T} .
Step 9	Prepare CADD notes for bridge plans.
Step 10	Check the design. ⁽²⁾
Construction Steps	
Step 11	Request and check contractor's hammer data, and prepare bearing graph for WEAP control or other necessary items for alternate methods of construction control.
Step 12	Observe construction, record driven resistance, and resolve any construction issues.

(1) These steps determine the basic information for geotechnical pile design and will vary depending on bridge project and Bureau practice.

(2) Checking will vary depending on bridge project and Bureau practice.

Within the Bridges and Structures Bureau at the Iowa DOT, the design steps that determine the basic information necessary for design of a steel H-pile generally follow as indicated in Steps 1-3. The steps involve communication among the preliminary design engineer, soils design engineer, and final design engineer. In other organizations the basic information may be determined differently, but that process generally should not affect the overall design of the pile.

Step 1 - Develop bridge situation plan (or TS&L, Type, Size, and Location)

For a typical bridge the preliminary design engineer plots topographical information, locates the bridge, determines general type of superstructure, location of substructure units, elevations of foundations, hydraulic information (if needed), and other basic information to characterize the bridge. The preliminary design engineer then prepares a TS&L sheet that shows a plan and longitudinal section of the bridge.

For this example for a state project, the TS&L gives the following information needed for design

of abutment piles:

- 120-foot single span, prestressed concrete beam superstructure
- Zero skew
- Integral abutments (because these are standard practice for non-skewed concrete bridges less than 575 feet in length with end or single spans not exceeding the length of standard prestressed concrete beams) [BDM 6.5.1.1.1]
- Pile foundations, no prebored holes (because the bridge length is less than 130 feet) [BDM 6.5.1.1.1]
- Bottom of west abutment footing elevation 433 feet

Step 2 - Develop soils package, including soil borings and foundation recommendations

Based on location of the abutments the soils design engineer orders soil borings, typically at least one per substructure unit. When the engineer receives the boring logs he/she arranges for them to be plotted on a longitudinal section, checks any special geotechnical conditions on the site, and writes a recommendation for foundation type with any applicable special design considerations.

For this example, the recommendations are the following:

- Friction piles that tip out in the firm glacial clay layer
- Steel H-piles for the integral abutments
- Structural Resistance Level – 1 (which does not require a driving analysis by the Construction and Materials Bureau during design [BDM 6.2.6.1])
- Normal driving resistance (This will lead to $\phi_c = 0.60$ for the structural check.)
- No special site considerations for stability, settlement, or lateral movement (Therefore the Service I load will not be required for design.)
- Standard construction control based on WEAP analysis with no planned retap

The soil profile includes the following soil boring at the west abutment. Generally below the bottom of footing elevation there are three soil layers: 6 feet of soft silty clay, 9 feet of silty sand, and firm glacial clay to the bottom of the boring at 95 feet. Layer 3 is subdivided at a depth of 30 feet because nominal friction resistance step-increases at that elevation [BDM Table 6.2.7-2]. No groundwater was encountered in the boring.

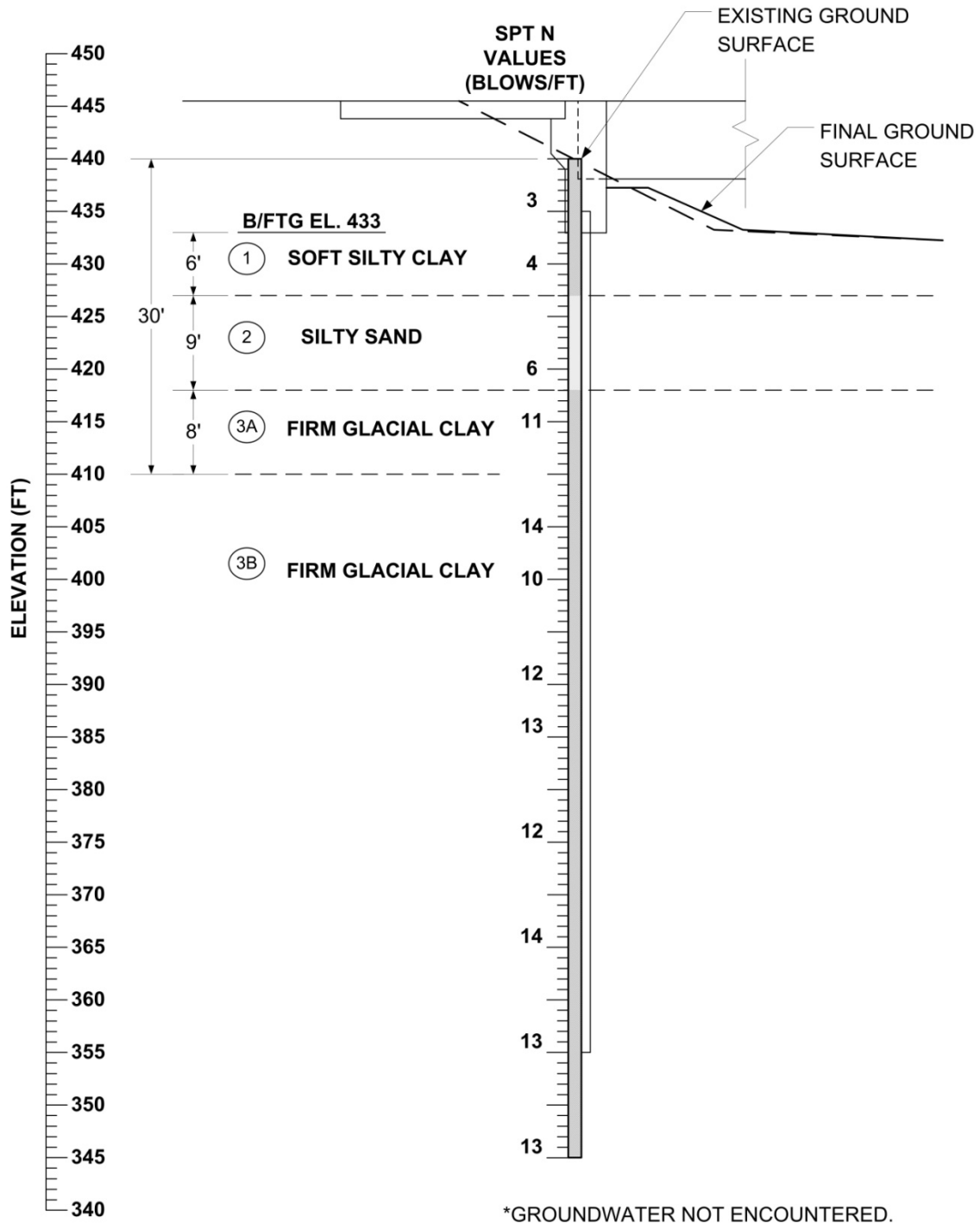

Track 1, Example 1-soil profile at west abutment

Step 3 - Determine pile layout, pile loads, and other design requirements. This step includes structural checks.

The final design engineer begins design of the abutment piles with the TS&L and the soils design package. Because the bridge has a prestressed concrete beam superstructure and integral abutments the engineer selects HP 10×57 piles, following Bridge Design Manual policy [BDM 6.5.1.1.1].

There is no uplift, downdrag, or scour. Because the bridge characteristics fall within integral abutment policy, the site has no unusual characteristics, the soils design engineer did not require further analysis, and construction will not be accelerated or delayed, there will be no need for lateral load or special analysis of the abutment piles. They may simply be designed for vertical load.

Notation: The same loads are designated in Step 3 with “P” (for structural checks) and in Steps 6 and 8 with “Q” (for geotechnical and driving checks).

For the west abutment

$$\Sigma \eta \gamma P + \gamma_{DD} DD = 895 + 0 = 895 \text{ kips} = P_u$$

The soils package indicates normal driving resistance, therefore

$$\phi_c = 0.60$$

The soils engineer recommends SRL-1 for which

$$P_n = 243 \text{ kips [BDM Table 6.2.6.1-1]}$$

Considering the TS&L and other project factors the final design engineer selects BTC beams [BDM Table 5.4.1.1.1]. For integral abutments with BTC beams and prebored holes for the piles, the maximum P_n is 365 kips [BDM Table 6.5.1.1.1-1]. With the short span, the prebored holes are not necessary and, for this project, 365 kips would be the limit per integral abutment pile. The SRL-1 value controls, however.

Required number of piles

$$n = P_u / \phi P_n = 895 / (0.60)(243) = 6.14, \text{ round to 7 piles}$$

Each pile then must carry

$$P_u = 895 / 7 = 128 \text{ kips}$$

The pile layout will be seven piles under the abutment plus one pile for each wing extension as shown below. (For the number of beams the designer checks the minimum number of piles, and for the abutment dimensions the designer checks the pile spacing guidelines [BDM 6.2.4.1].

Those checks are not shown here.) In this case the wing extension piles are added for abutment stability and are moderately loaded so they need not be checked for structural resistance.

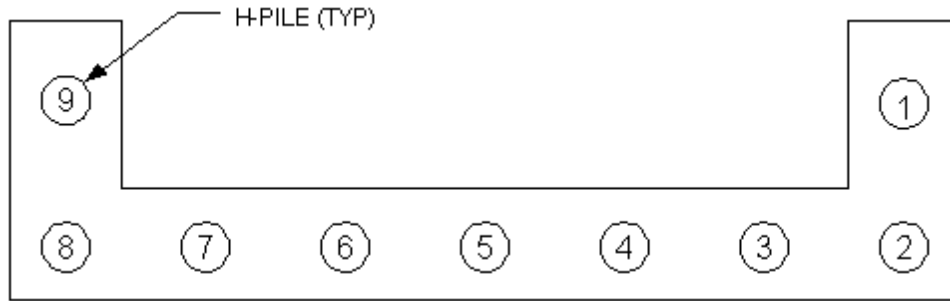

Track 1, Example 1-pile layout at west abutment

Step 4 – Estimate nominal geotechnical resistance for friction

Based on the west abutment soil boring and BDM Table 6.2.7-2, the final design engineer estimates the following nominal unit resistances for friction bearing.

Track 1, Example 1-estimated nominal unit geotechnical resistance

Soil Stratum	Soil Description		Stratum Thickness (ft)	Average SPT N Value (blows/ft)	Estimated Unit Nominal Resistance for Friction Pile (kips/ft)
1	Soft Silty Clay		6	4	0.8
2	Silty Sand		9	6	1.2
3A	Firm Glacial Clay	within 30 feet of natural ground elevation	8	11	2.8
3B		more than 30 feet below natural ground elevation	65	12	3.2

Abbreviation:

- SPT, standard penetration test

The firm glacial clay stratum has been divided into two parts, to delineate the embedded pile length that is within 30 feet of the natural ground surface as noted in the BDM geotechnical resistance chart [BDM Table 6.2.7-2]. Application of the chart to estimate the nominal resistance values is illustrated on the next page. Note that the SPT N values are too small for use of end bearing in Layer 3B [BDM Table 6.2.7-1].

Track 1, Example 1-geotechnical resistance chart [BDM Table 6.2.7-2]

SOIL DESCRIPTION	BLOW COUNT		ESTIMATED NOMINAL RESISTANCE VALUES FOR FRICTION PILE IN KIPS PER FOOT											
	N-VALUE		WOOD PILE	STEEL "H"			PRESTRESSED			STEEL PIPE				
	MEAN	RANGE		10	12	14	12	14	16	10	12	14	18	
Alluvium or Loess														
Very soft silty clay	1	0 - 1	0.8	0.4	0.8	0.8	0.8	0.8	0.8	0.8	0.4	0.4	0.4	0.8
Soft silty clay	3	2 - 4	1.2	0.8	1.2	1.2	0.8	0.8	0.8	0.8	0.8	0.8	0.8	1.2
Stiff silty clay	6	4 - 8	1.6	1.2	1.6	2.0	1.2	1.6	2.0	1.2	1.2	1.6	2.0	2.0
Firm silty clay	11	7 - 15	2.4	2.0	2.4	2.8	2.4	2.8	3.2	1.6	2.0	2.4	2.8	2.8
Stiff silt	6	3 - 7	1.6	1.2	1.6	1.6	1.6	1.6	1.6	1.2	1.2	1.6	1.6	1.6
Stiff sandy silt	6	4 - 8	1.6	1.2	1.6	1.6	1.6	1.6	1.6	1.2	1.2	1.6	1.6	1.6
Stiff sandy clay	6	4 - 8	1.6	1.2	1.6	2.0	2.0	2.0	2.4	1.2	1.6	1.6	2.0	2.0
Silty sand	8	3 - 13	1.2	1.2	1.2	1.6	1.6	1.6	1.6	0.8	0.8	1.2	1.6	1.6
Clayey sand	13	6 - 20	2.0	1.6	2.0	2.8	2.4	2.4	2.8	1.6	2.0	2.4	2.8	2.8
Fine sand	15	8 - 22	2.4	2.0	2.4	2.8	2.4	2.8	3.2	1.6	2.0	2.4	2.8	2.8
Coarse sand	20	12 - 28	3.2	2.8	3.2	3.6	3.2	3.6	4.0	2.0	2.4	2.8	3.6	3.6
Gravelly sand	21	11 - 31	3.2	2.8	3.2	3.6	3.6	3.6	4.0	2.0	2.4	2.8	3.6	3.6
Granular material	> 40	---	(2)	4.0	4.8	5.6	(2)	(2)	(2)	(2)	(2)	(2)	(2)	(2)
Glacial Clay														
Firm silty glacial clay	11	7 - 15	2.8	2.4	2.8	3.2	2.8	3.2	3.6	2.0	2.4	2.4	3.2	3.2
Firm clay (gumbotil)	12	9 - 15	2.8	2.4	2.8	3.2	2.8	3.2	3.6	2.0	2.4	2.4	3.2	3.2
Firm glacial clay ⁽¹⁾	11	7 - 15	2.4	2.8	3.2	3.6	3.2	3.6	4.0	2.0	2.4	2.8	3.6	3.6
			[3.2]	[3.2]	[4.0]	[4.4]	[4.0]	[4.4]	[4.8]	[2.4]	[2.8]	[3.2]	[4.4]	[4.4]
Firm sandy glacial clay ⁽¹⁾	13	9 - 15	2.4	2.8	3.2	3.6	3.2	3.6	4.0	2.0	2.4	2.8	3.6	3.6
			[3.2]	[3.2]	[4.0]	[4.4]	[4.0]	[4.4]	[4.8]	[2.4]	[2.8]	[3.2]	[4.4]	[4.4]
Firm - very firm glacial clay ⁽¹⁾	14	11 - 17	2.8	2.8	3.2	3.6	4.0	4.4	4.8	2.4	2.8	3.2	4.0	4.0
			[3.6]	[4.0]	[4.8]	[5.6]	[4.8]	[5.2]	[5.6]	[3.2]	[3.6]	[4.0]	[5.2]	[5.2]
Very firm glacial clay ⁽¹⁾	24	17 - 30	2.8	2.8	3.2	3.6	3.2 ⁽³⁾	3.6 ⁽³⁾	4.4 ⁽³⁾	2.4	2.8	3.2	4.0	4.0
			[3.6]	[4.0]	[4.8]	[5.6]	[4.8]	[5.6]	[6.4]	[3.2]	[3.6]	[4.0]	[5.2]	[5.2]
Very firm sandy glacial clay ⁽¹⁾	25	15 - 30	3.2	2.8	3.2	3.6	3.2 ⁽³⁾	3.6 ⁽³⁾	4.4 ⁽³⁾	2.4	2.8	3.2	4.0	4.0
			[4.0]	[4.0]	[4.8]	[5.6]	[4.8]	[5.6]	[6.4]	[3.2]	[3.6]	[4.0]	[5.2]	[5.2]
Cohesive or glacial material ⁽¹⁾	> 35	---	(2)	2.8	3.2	3.6	(2)	(2)	(2)	2.0 ⁽⁴⁾	2.4 ⁽⁴⁾	2.8 ⁽⁴⁾	3.6 ⁽⁴⁾	3.6 ⁽⁴⁾
				[4.0]	[4.8]	[5.6]				[3.2]	[4.0]	[4.4]	[5.6]	[5.6]

Table notes:

- (1) For double entries the upper value is for an embedded pile within 30 feet of the natural ground elevation, and the lower value [] is for pile depths more than 30 feet below the natural ground elevation.
- (2) Do not consider use of this pile type for this soil condition, wood with N > 25, prestressed concrete with N > 35, or steel pipe with N > 40.
- (3) Prestressed concrete piles have proven to be difficult to drive in these soils. Prestressed piles should not be driven in glacial clay with consistent N > 30 to 35.
- (4) Steel pipe piles should not be driven in soils with consistent N > 40.

Step 5 - Select resistance factor to estimate pile length based on the soil profile and construction control

In this step the final design engineer first characterizes the site as cohesive, mixed, or non-cohesive based on soil classification in the table below and the soil profile.

Track 1, Example 1-soil classification table [BDM Table 6.2.8]

Generalized Soil Category	Soil Classification Method			
	AASHTO	USDA Textural	BDM 6.2.7 Geotechnical Resistance Charts	
Cohesive	A-4, A-5, A-6 and A-7	Clay Silty clay Silty clay loam Silt Clay loam Silt loam Loam Sandy clay	Loess	Very soft silty clay
				Soft silty clay
				Stiff silty clay
				Firm silty clay
				Stiff silt
			Glacial Clay	Stiff sandy clay
				Firm silty glacial clay
				Firm clay (gumbotil)
				Firm glacial clay
				Firm sandy glacial clay
				Firm-very firm glacial clay
				Very firm glacial clay
				Very firm sandy glacial clay
				Cohesive or glacial material
Non-Cohesive	A-1, A-2 and A-3	Sandy clay loam Sandy loam Loamy sand Sand	Alluvium Or Loess	Stiff sandy silt
				Silty sand
				Clayey sand
				Fine sand
				Coarse sand
				Gravelly sand
				Granular material (N>40)

Abbreviations:

- AASHTO, American Association of State Highway and Transportation Officials
- USDA, U.S. Department of Agriculture

Only the 9-foot Layer 2 of silty sand is classified as non-cohesive. The remainder of the profile is classified as cohesive, and most likely will represent more than 70% of the pile embedment length. Thus the soil is expected to fit the cohesive classification, and the resistance factor selection from the three available choices below is 0.65 [BDM Table 6.2.9-1].

- $\phi = 0.65$ for **cohesive** soil, averaged over the full depth of estimated pile penetration
- $\phi = 0.65$ for **mixed** soil, averaged over the full depth of estimated pile penetration
- $\phi = 0.55$ for **non-cohesive** soil, averaged over the full depth of estimated pile penetration

Step 6 - Calculate required nominal pile resistance, R_n

The required nominal pile resistance is:

$$R_n = \frac{\sum \eta \gamma Q + \gamma_{DD} DD}{\phi} = \frac{128 + 0}{0.65} = 197 \text{ kips/pile}$$

where

$$\sum \eta \gamma Q = \gamma Q = 128 \text{ kips (Step 3)}$$

$$\gamma_{DD} DD = 0 \text{ (no downdrag)}$$

$$\phi = 0.65 \text{ (Step 5)}$$

Step 7 – Estimate contract pile length, L

Based on the nominal resistance values in Step 4, the cumulative nominal geotechnical resistance, R_{n-BB} , per pile is calculated as follows, where D = depth in feet below the bottom of footing.

$$D_0 = 0 \text{ ft, } R_{n-BB0} = 0$$

$$D_1 = 6 \text{ ft, } R_{n-BB1} = R_{n-BB0} + (0.8 \text{ kips/ft}) (6 \text{ ft}) = 4.8 \text{ kips}$$

$$D_2 = 6 + 9 = 15 \text{ ft, } R_{n-BB2} = R_{n-BB1} + (1.2 \text{ kips/ft}) (9 \text{ ft}) = 4.8 + 10.8 = 15.6 \text{ kips}$$

$$D_3 = 15 + 8 = 23 \text{ ft, } R_{n-BB3} = R_{n-BB2} + (2.8 \text{ kips/ft}) (8 \text{ ft}) = 15.6 + 22.4 = 38.0 \text{ kips}$$

$$D_4 = 23 + 65 = 88 \text{ ft, } R_{n-BB4} = R_{n-BB3} + (3.2 \text{ kips/ft}) (65 \text{ ft}) = 38.0 + 208.0 = 246.0 \text{ kips}$$

A graphic presentation of the estimated nominal geotechnical resistance per pile versus depth is presented below.

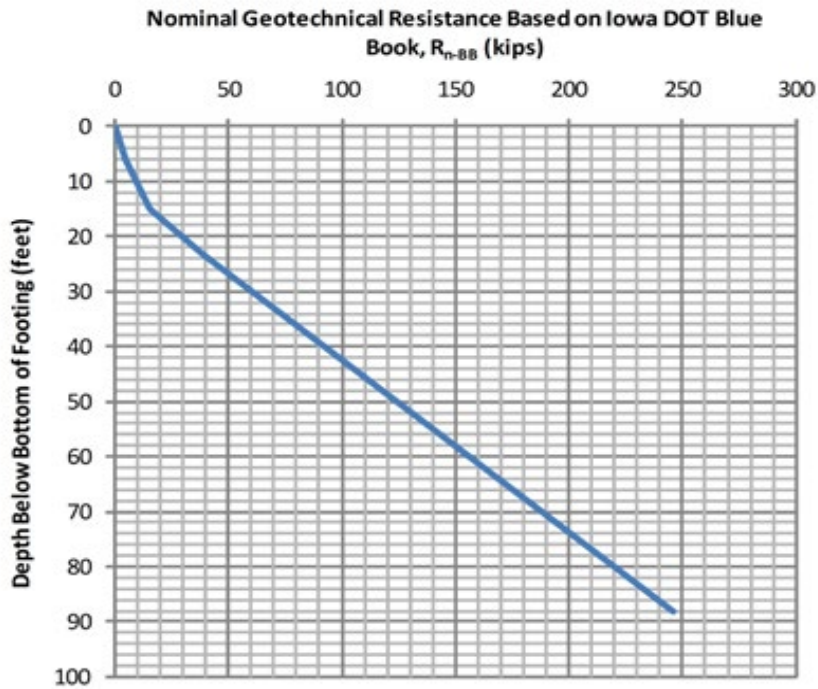

Track 1, Example 1-a plot of nominal geotechnical resistance versus depth

From the graph the depth below the footing necessary to achieve 197 kips is about 73 feet and may be computed as follows:

$$D_L = 23 + (197-38.0)/3.2 = 72.7 \text{ feet}$$

The contract pile length includes a 2-foot embedment in the footing [BDM Table 6.2.5] and a 1-foot allowance for cutoff due to driving damage [BDM 6.2.4.2].

$$L = 72.7 + 2 + 1 = 75.7 \text{ feet}$$

The length for steel H-piles is specified in 5-foot increments [BDM 6.2.4.2]. Therefore, the contract pile length is 75 feet, with 72 feet embedded.

At this point the embedded pile length is known, and it is necessary to check the resistance factor.

$$\% \text{ cohesive soil} = [(72-9)/72] (100) = 88\% > 70\%$$

Therefore, the resistance factor for cohesive soil is the correct choice. If the resistance factor were incorrect the engineer would need to repeat Steps 6 and 7 (although in this example the mixed soil classification would not result in numerical changes).

Step 8 - Estimate target nominal pile driving resistance, R_{ndr-T}

For a driven H-pile with no planned retap and use of a WEAP analysis for construction control, the following resistance factors, ϕ , are recommended to estimate the target nominal pile driving resistance [BDM Table 6.2.9-3].

$\phi_{EOD} = 0.65$ for cohesive soil, averaged over the full depth of estimated pile penetration

$\phi_{SETUP} = 0.20$ for cohesive soil, averaged over the full depth of estimated pile penetration

$\phi = 0.65$ for mixed soil, averaged over the full depth of estimated pile penetration

$\phi = 0.55$ for non-cohesive soil, averaged over the full depth of estimated pile penetration

The nominal pile resistance during construction, R_n , will be determined at end of drive by scaling back 7-day setup gain, and then adjusting retaps to account for setup.

$$\sum \eta \gamma Q + \gamma_{DD} DD \leq \phi R_n \text{ where } \eta = \text{load modifier} = 1.0 \text{ from BDM 6.2.3.1}$$

Let $R_n = R_T$ = nominal pile resistance at time T (days) after EOD.

$$R_{EOD} \geq \frac{\sum \eta \gamma Q + \gamma_{DD} DD}{\phi_{EOD} + \phi_{SETUP}(F_{SETUP} - 1)}$$

where

$$\sum \eta \gamma Q = \gamma Q = 128 \text{ kips, (Step 2)}$$

$$\gamma_{DD} DD = 0 \text{ (no downdrag)}$$

$$F_{SETUP} = \text{Setup Ratio} = R_T/R_{EOD}$$

To determine the setup ratio the soil profile was used to calculate the average SPT N-value for the cohesive soil layers penetrated by the driven pile over the contract pile length, as follows.

$$\text{Calculated average SPT N-value} = [(6')(4) + (8')(11) + (72'-23')(12)]/(72'-9') = 11$$

The average SPT N-value of 11 yields a Setup Ratio, F_{SETUP} , of 1.47 for 1-day retap, 1.55 for 3-day retap and 1.61 for 7-day retap from the graph shown below [BDM Figure 6.2.10].

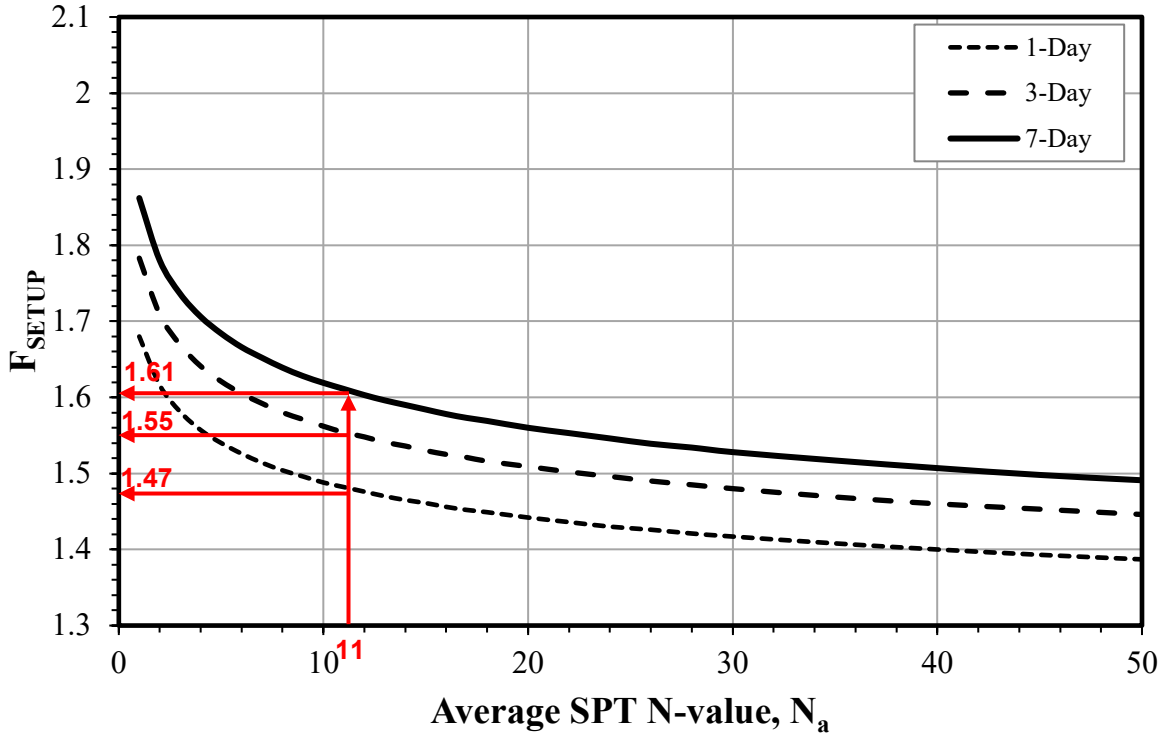

Track 1, Example 1-pile setup factor chart [BDM Figure 6.2.10]

Let ϕ_{TAR} = Resistance factor for target nominal resistance ≤ 1.00

$$= \phi_{EOD} + \phi_{SETUP}(F_{SETUP} - 1),$$

and $R_{ndr-T} = R_{EOD}$

The target pile driving resistance at end of drive is

$$\begin{aligned}
 R_{ndr-T} &= R_{EOD} \\
 &\geq \frac{\sum \eta \gamma Q + \gamma_{DD} DD}{\phi_{TAR}} \\
 &\geq \frac{\sum \eta \gamma Q + \gamma_{DD} DD}{\phi_{EOD} + \phi_{SETUP}(F_{SETUP} - 1)} \\
 &\geq \frac{128 + 0}{(0.65) + (0.20)(1.61 - 1)} = \frac{128}{0.77} \\
 &= 166 \text{ kips} = 83 \text{ tons}
 \end{aligned}$$

Note that $\phi_{TAR} < 1.00$, OK

The target nominal geotechnical resistance at 1-day retap then is:

$R_{1\text{-day}} = (166.0)(1.47) = 244 \text{ kips} = 122 \text{ tons}$, but not more than $R_{\text{ndr-T}}$ computed with ϕ_{EOD} , not considering setup.

$R_{1\text{-day}} \leq (128 + 0)/0.65 = 197 \text{ kips} = 99 \text{ tons}$

The 99 tons controls and also will control 3-day and 7-day retaps (which otherwise would be 129 tons and 134 tons, respectively).

Step 9 – Prepare CADD notes for the bridge plans

At this point the final design engineer selects the appropriate CADD notes for the abutment and pier plan sheets and adds the specific pile load values to the notes [BDM 13.8.2].

E818: Abutment piles, LRFD contract length and resistance

THE CONTRACT LENGTH OF 75 FEET FOR THE WEST ABUTMENT PILES IS BASED ON A COHESIVE SOIL CLASSIFICATION, A TOTAL FACTORED AXIAL LOAD PER PILE (P_U) OF 128 KIPS, AND A GEOTECHNICAL RESISTANCE FACTOR (ϕ) OF 0.65.

THE NOMINAL AXIAL BEARING RESISTANCE FOR CONSTRUCTION CONTROL WAS DETERMINED FROM A COHESIVE SOIL CLASSIFICATION AND A GEOTECHNICAL RESISTANCE FACTOR (ϕ) OF 0.77. PILES ARE ASSUMED TO BE DRIVEN FROM A START ELEVATION AT THE BOTTOM OF FOOTING.

E819: Abutment piles, driving and construction control

THE REQUIRED NOMINAL AXIAL BEARING RESISTANCE FOR WEST ABUTMENT PILES IS 83 TONS AT END OF DRIVE. IF RETAPS ARE NECESSARY TO ACHIEVE BEARING, THE REQUIRED NOMINAL AXIAL BEARING RESISTANCE IS 99 TONS AT ONE-DAY OR LATER RETAPS. THE PILE CONTRACT LENGTH SHALL BE DRIVEN AS PER PLAN UNLESS PILES REACH REFUSAL. CONSTRUCTION CONTROL REQUIRES A WEAP ANALYSIS WITH BEARING GRAPH.

Step 10 – Check the design

Within the Bridges and Structures Bureau at the Iowa DOT a final design engineer other than the bridge designer is assigned to give the bridge design an independent check at the time final plans are complete. During the checking process a final design engineer will review the soils package to ensure that all recommendations were followed and also will check structural, geotechnical, and drivability aspects of the design.

Other design organizations may perform checks at various stages of design rather than upon plan completion.

-----**END DESIGN PHASE**-----

-----**BEGIN CONSTRUCTION PHASE**-----

Step 11 – Request and check contractor’s hammer data, and prepare bearing graph for WEAP control

After the bridge contract is let and prior to start of pile driving, the contractor completes Hammer Data sheets for the pile driving hammer that he/she plans to use. The Hammer Data sheets include all pertinent information including the cap (helmet) number and hammer identification information with details, hammer cushion, and pile cushion (where required), as well as pile size, pile length, and estimated pile driving resistance. The Construction and Materials Bureau uses the data received to complete a WEAP analysis for construction control during pile driving. Results from the WEAP analysis are then used to prepare an LRFD Bearing Graph (without the factor of safety used for allowable stress design). The Bearing Graph includes curves of nominal driving resistance versus blows per foot, and identifies specific driving conditions, where driving stress is a concern. The figure below is the LRFD Bearing Graph for the west abutment.

Special Driving Conditions	Stroke (ft)	Monitor at 10 Blow Increments	Do NOT Exceed	Project No: Design Example DGT11	Graph No: XX-XXXX-XX-XXX
	7	-----	-----	Design No: XXX	Hammer No: XXXXXX
Blows per foot	8	-----	-----	County: XXXXX	Cap No: XXX
	9	-----	-----	Location: West Abutment	Pile Type: HP 10x57
				Hammer: Delmag D19-42	Pile Length: 75 feet

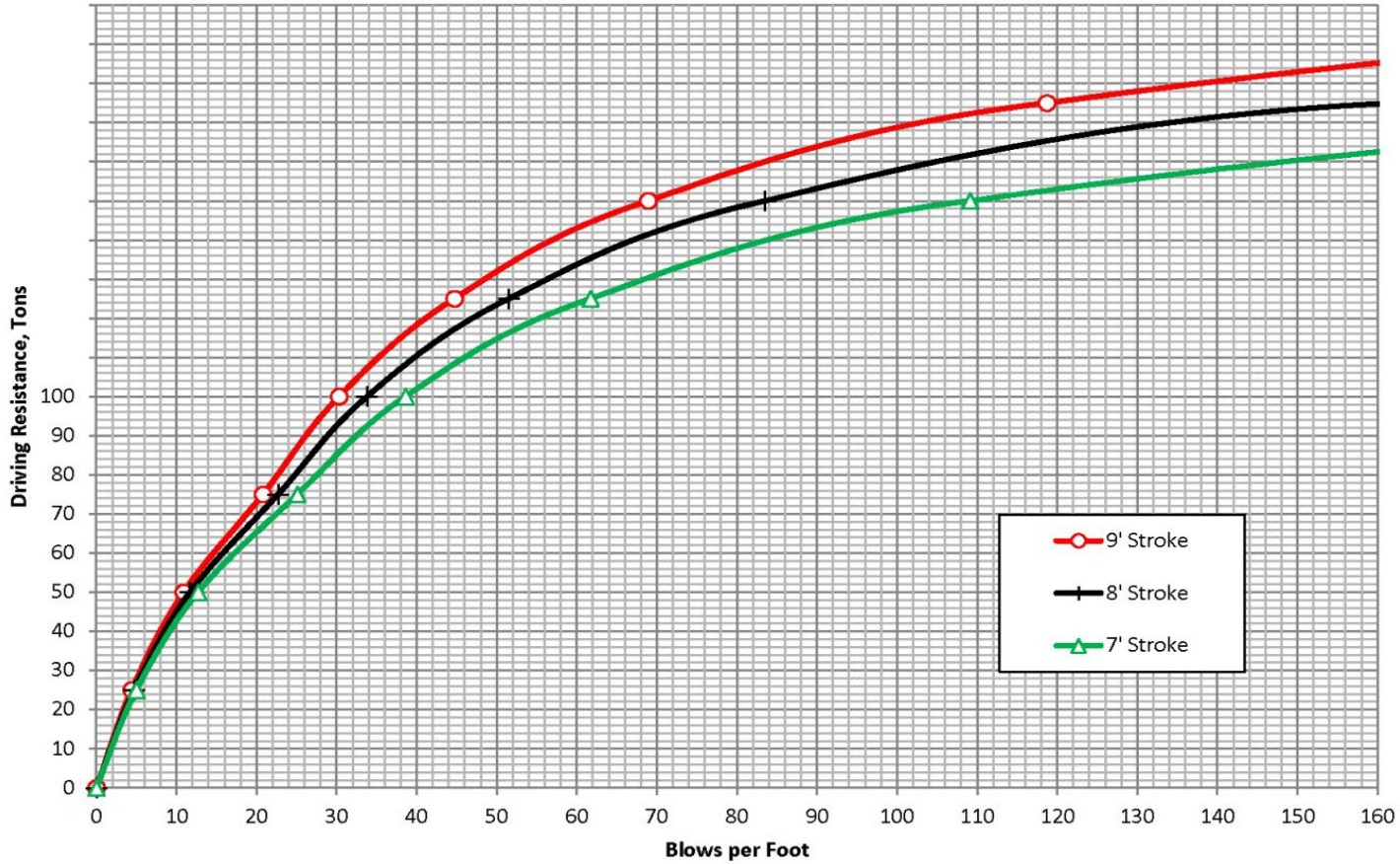

Track 1, Example 1-general WEAP bearing graph

Step 12 - Observe construction, record driven resistance, and resolve any construction issues

During pile driving, the construction inspector records the hammer stroke and number of blows to advance the pile an equivalent penetration of 1 foot, and then converts the recorded information with the Bearing Graph to record the driven resistance per pile at EOD. This information is shown for this example in the English Log of Piling Driven with Wave Equation below.

If the recorded pile driving resistance at EOD is less than the target pile nominal driving resistance, then the pile is retapped about 24 hours after EOD. (The retap is a remedial measure that makes use of setup for an individual pile. If the 24-hour retap does not indicate enough driven resistance, an extension will be added. An extension is expensive, and the designer should not overestimate the benefit of setup.)

For example, at EOD for the planned pile embedment length at Pile 1, the construction inspector recorded a hammer stroke of 7-1/2 feet and a blow count of 30 blows per foot for the last foot of pile penetration, as shown on the log below. Based on the Bearing Graph the construction inspector recorded a driving resistance of 88 tons, which is greater than the target driving resistance of 83 tons.

Pile 4 illustrates the use of pile retaps. At EOD at Pile 4, the construction inspector recorded a driving resistance of 69 tons, which is less than the target nominal pile driving resistance of 83 tons. Twenty-four hours after EOD, Pile 4 was retapped, with a retap target nominal driving resistance of 99 tons. The pile driving hammer was warmed up with 20 blows on another pile; and after two blows on Pile 4 to set the cap, Pile 4 was retapped 10 blows with a measured driven penetration distance of 3-1/2 inches ($10 \times 12/3.5 = 34$ blows per foot) at a stroke of 8-1/2 feet. The Pile 4 retap resulted in a retap driving resistance of 100 tons (or 103 tons depending on reading of the graph), which is greater than the retap target driving resistance of 99 tons. The driving log shows that all other piles reached the target resistance at contract length and EOD with relatively little variation.

If the production pile could not reach the target nominal pile driving resistance of 99 tons at the retap event, the production pile could be spliced with an extension pile, and redriving could be continued to avoid any delay in construction. At this point, the pile setup resistance initially developed is assumed none. The pile can be extended until the new field-measured pile driving resistance reaches the target nominal driving resistance at EOD of 83 tons estimated in Step 8 and described in the CADD note.



ENGLISH LOG OF PILING DRIVEN WITH WAVE EQUATION

Project No. Someplace in Iowa Pile (Type and Size) HP 10x57
(Wood/Steel/Concrete)
 County XXX
 Design No. 389 Hammer (Type & Model) Delmag D19-42
(Gravity or Diesel/Manufacturer and model)
 Contractor XXXX
 Driving Graph No. XX-XXXX-XX-XXX Foundation Description West Abutment
(North abut, Pier 1, etc.)
 Nominal Driving Resistance 83 Tons Station of Foundation C.L. 447+00

Sketch foundation below, number each pile and show steel H-pile orientation as installed. Note battered piles on sketch, and give the amount of batter. Place name and certificate number of welder below if welding was necessary. Forward copies, including driving graph, as outlined in the construction manual. Note on drawing which pile has been logged.

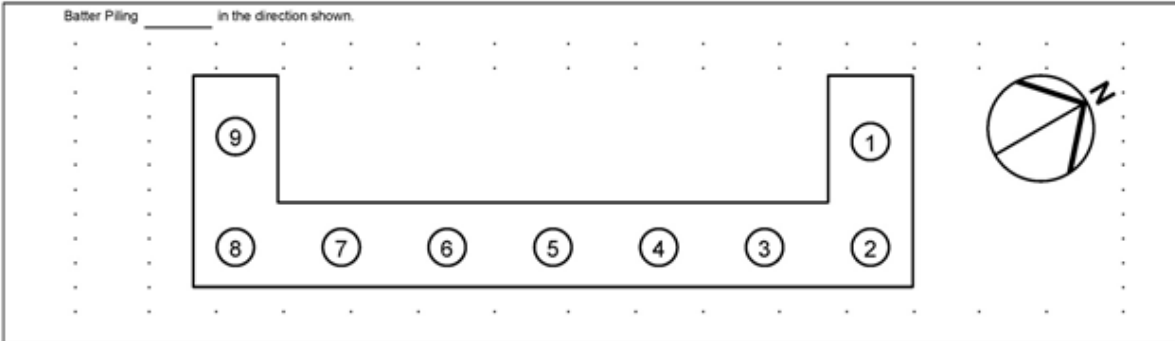

Pile No.	Date Driven	(1) Plan Length (ft.)	Length Cutoff (0.0 ft.)	Blows Per Foot	Ram Rise (ft.)	Driven Resistance (Tons)	RETAP (2)			PILE EXTENSIONS (3)					Welds (Count)	
							Date	Ram Rise (ft.)	Blows Per Foot	Driven Resistance (Tons)	Length Added (0.0 ft.)	Length Cutoff (0.0 ft.)	Ram Rise (ft.)	Blows Per Foot		Driven Resistance (Tons)
1	X-XX-XX	75	1.5	30	7.5	88										
2	X-XX-XX	75	4.5	32	8	96										
3	X-XX-XX	75	2.5	31	7	87										
4	X-XX-XX	75	1.0	20	8	69	X-XX-XX	8.5	34	100						
5	X-XX-XX	75	2.0	28	9	94										
6	X-XX-XX	75	2.0	26	8.5	86										
7	X-XX-XX	75	2.5	30	7.5	89										
8	X-XX-XX	75	4.0	35	7	94										
9	X-XX-XX	75	2.0	28	8.5	90										
--	--	--	--	--	--	--										

(1) Record in the Remarks section below if the pile length is anything other than the plan length at the beginning of drive.
 (2) Indicate date of retap in date column (1 day delay min.). List only pile actually checked.
 (3) Additional pile length to be authorized by Construction Office.

Total Welds: _____
 Plan Length: _____ Feet
 Extensions: _____ Feet
 Total: _____ Feet

Welders Name: _____ Lab No.: _____ Exp. Date: _____
 Remarks: _____

Inspector _____ Date _____ Project Engineer _____

Distribution: Construction (original), District, Project File

Track 1, Example 1-pile driving log

Track 1, Example 2

Driven H-Pile in Mixed Soil with Scour, and Construction Control Based on Wave Equation and No Planned Retap

General design and construction steps to be modified for project conditions

Design Steps	
Step 1	Develop bridge situation plan (or TS&L, Type, Size, and Location). ⁽¹⁾
Step 2	Develop soils package, including soil borings and foundation recommendations. ⁽¹⁾
Step 3	Determine pile layout, pile loads including downdrag, and other design requirements. ⁽¹⁾ This step includes structural checks.
Step 4	Estimate nominal geotechnical resistance for friction and end bearing.
Step 5	Select resistance factor(s) to estimate pile length based on the soil profile and construction control.
Step 6	Calculate required nominal pile resistance, R_n .
Step 7	Estimate contract pile length, L , considering downdrag, scour, pile uplift, lateral loading, and unbraced length, if applicable.
Step 8	Estimate target nominal pile driving resistance, R_{ndr-T} .
Step 9	Prepare CADD notes for bridge plans.
Step 10	Check the design. ⁽²⁾
Construction Steps	
Step 11	Request and check contractor's hammer data, and prepare bearing graph for WEAP control or other necessary items for alternate methods of construction control.
Step 12	Observe construction, record driven resistance, and resolve any construction issues.

(1) These steps determine the basic information for geotechnical pile design and will vary depending on bridge project and Bureau practice.

(2) Checking will vary depending on bridge project and Bureau practice.

Within the Bridges and Structures Bureau at the Iowa DOT, the design steps that determine the basic information necessary for design of a steel H-pile generally follow as indicated in Steps 1-3. The steps involve communication among the preliminary design engineer, soils design engineer, and final design engineer. In other organizations the basic information may be determined differently, but that process generally should not affect the overall design of the pile.

Step 1 - Develop bridge situation plan (or TS&L, Type, Size, and Location)

For a typical bridge the preliminary design engineer plots topographical information, locates the bridge, determines general type of superstructure, location of substructure units, elevations of foundations, hydraulic information (if needed), and other basic information to characterize the bridge. The preliminary design engineer then prepares a TS&L sheet that shows a plan and longitudinal section of the bridge.

For this example for a state project, the TS&L gives the following information needed for design of T-pier piles:

- 208-foot three span, prestressed concrete beam superstructure
- Zero skew
- T-piers
- Pile foundation
- Bottom of pier footing elevation 435 feet
- Design scour elevation of 425 feet and check scour elevation of 424 feet (This indicates 10 feet of scour to be considered at the strength limit state and 11 feet of scour to be considered at the extreme event limit state.)

Step 2 - Develop soils package, including soil borings and foundation recommendations

Based on location of the bridge abutments and piers the soils design engineer orders soil borings, typically at least one per substructure unit. When the engineer receives the boring logs he/she arranges for them to be plotted on a longitudinal section, checks any special geotechnical conditions on the site, and writes a recommendation for foundation type with any applicable special geotechnical design considerations.

For this example, the recommendations are the following:

- Friction piles with end bearing that tip out in the very firm glacial clay layer
- Steel H-piles for the T-piers
- Structural Resistance Level – 1 (which does not require a driving analysis by the Construction and Materials Bureau during design) [BDM 6.2.6.1]
- No downdrag
- Normal driving resistance (This will lead to $\phi_c = 0.6$ for the structural check.)
- No special site considerations for stability, settlement, or lateral movement (Therefore a Service I load will not be required for design.)
- Standard construction control based on WEAP analysis with no planned retap

Subsurface conditions at Pier #1 have been characterized based on a representative test boring, as indicated in the soil profile on the next page. Below the bottom of footing elevation, subsurface conditions generally consist of three layers: about 33 feet of silty sand, 13 feet of firm silty clay, and deeper very firm glacial clay. The test boring was terminated at a depth of 95 feet below the existing ground surface, and ground water was encountered at Elevation 439.

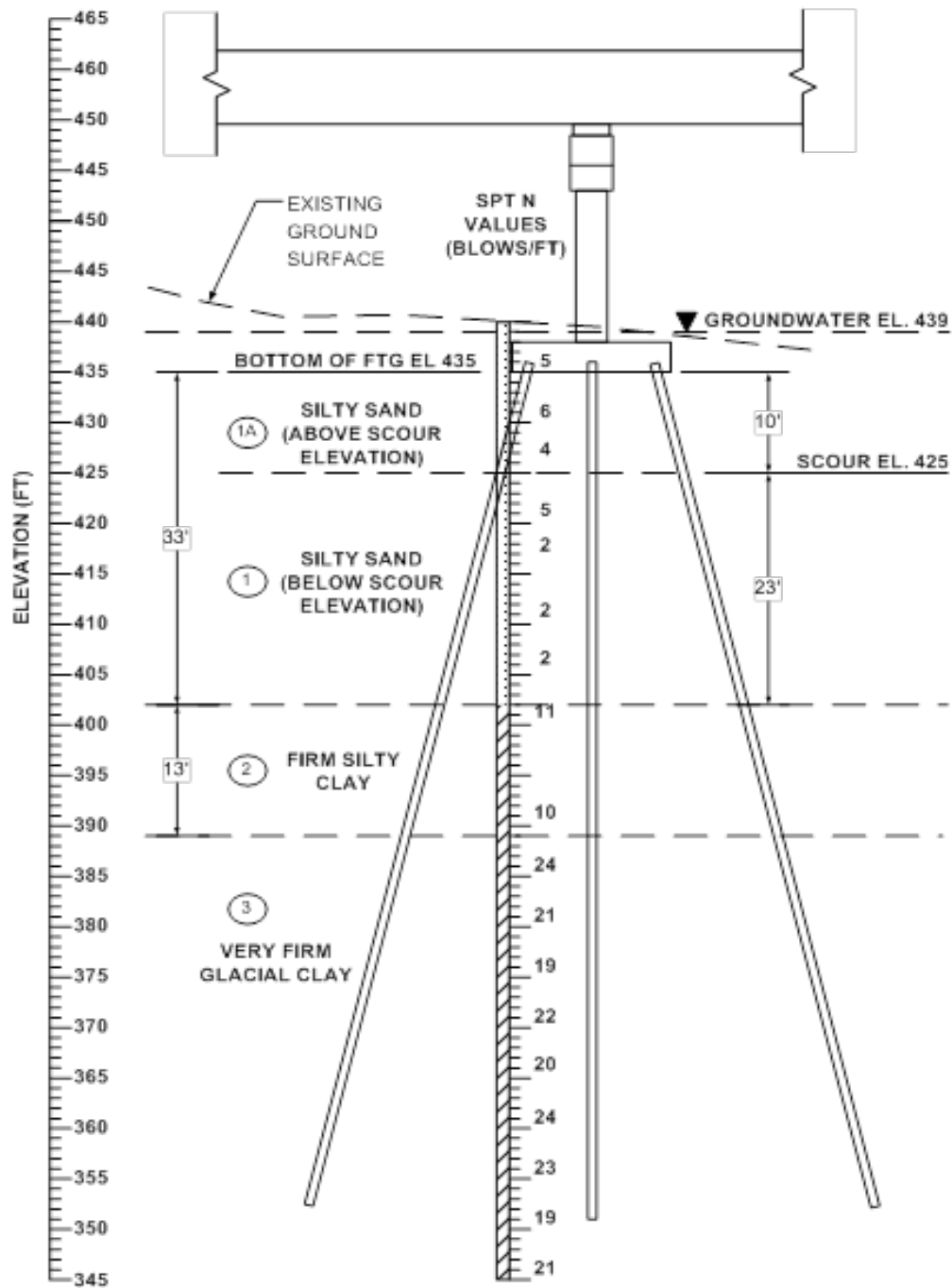

Track 1, Example 2-soil profile at Pier #1

Step 3 - Determine pile layout, pile loads, and other design requirements. This step includes structural checks.

The final design engineer begins design of the pier piles with the TS&L and the soils design package. Because the bridge has a prestressed concrete beam superstructure and integral

abutments the engineer selects HP 10×57 piles for Pier #1 to match abutment piles, following Bridge Design Manual policy [BDM 6.5.1.1.1 and 6.2.1.1].

Based on RCPIER analysis at the strength limit state and Bridge Design Manual policy for pile spacing and number of piles [BDM 6.5.4.1.1], the final design engineer determines the following:

- Eighteen Grade 50, HP 10×57 piles at 4'-6" spacing, arranged in three rows of six as shown below
- Perimeter piles battered at 1:4, as indicated by the arrows shown below
- Maximum factored, axial Strength I load for one pile = 143 kips
- Maximum factored, lateral Strength III load for one pile = 5 kips
- No uplift

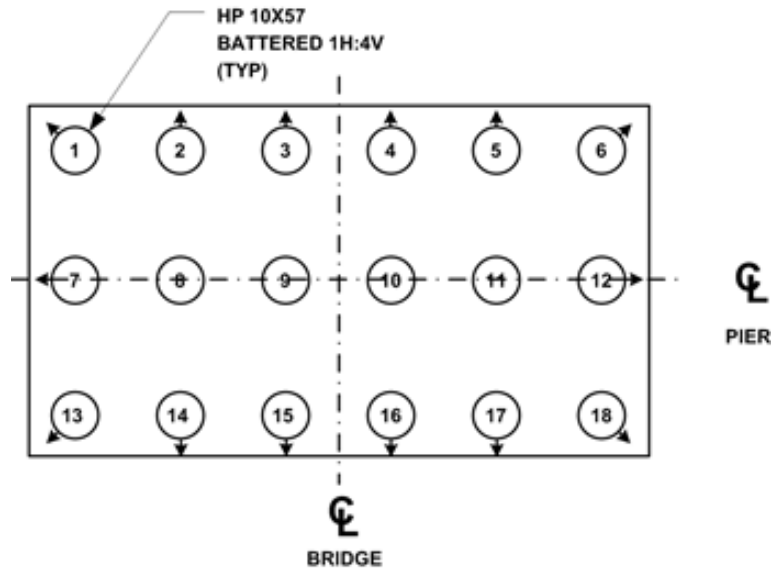

Track 1, Example 2-pile layout at Pier #1

Notation: The same loads are designated in Step 3 with “P” and in Steps 6 and 8 with “Q”.

First, check Structural Resistance Level – 1 (SRL-1) recommended by the soils engineer [BDM Table 6.2.6.1-1].

$$\text{For a HP 10x57, } P_n = 243 \text{ kips}$$

The soils package indicates normal driving resistance, therefore

$$\phi_c = 0.60$$

Then

$$\phi_c P_n = (0.60)(243) = 146 \text{ kips} > [P_u = 143 \text{ kips}] \text{ OK}$$

(The second and third checks below are for illustration. They could be condensed to a simple check of the pile unsupported height against the appropriate value in BDM Table 6.6.4.1.3.1-2 as follows.

$$[10 + 4 = 14 \text{ feet} < 16.0 \text{ feet OK}]$$

Second, check the slenderness ratio of a pile under design scour [BDM 6.6.4.1.3.1]. A pile is assumed to be supported at the bottom of the footing and at 4 feet below the scour elevation, and K may be taken as 1.0. For design scour and SRL-1 the maximum slenderness ratio is 80 [BDM Table 6.6.4.1.3.1-1]. For a HP 10x57, $r_y = 2.45$ inches.

$$KL/r = (1.0)(10+4)(12)/2.45 = 68.6 < 80 \text{ OK}$$

Third, check the pile axial resistance considering the unsupported length after design scour and using the AASHTO LRFD Specifications.

$$\phi_c = 0.90 \quad [\text{AASHTO-LRFD 6.5.4.2}]$$

$$P_o = QF_y A_g = (1.0)(50)(16.7) = 835 \text{ kips} \quad [\text{AASHTO-LRFD 6.9.4.1.1}]$$

Note that the area of the HP 10x57 shape was reduced to 16.7 in² in the 14th Edition of *Steel Construction Manual*.

Where Q = slender element reduction factor, in this case for an HP 10x57 = 1.0. For some H-pile sections Q may be a reduction factor.

$$KL/r_s = 68.6 \quad [\text{AASHTO-LRFD 6.9.4.1.2}]$$

$$P_e = \pi^2 E A_g / (KL/r_s)^2 = 1016 \text{ kips} \quad [\text{AASHTO-LRFD 6.9.4.1.2}]$$

Torsional buckling does not apply because $K_z L_z = K_y L_y$ [AASHTO-LRFD Table 6.9.4.1.1-1].

$$P_e/P_o = 1016/835 = 1.22 \quad [\text{AASHTO-LRFD 6.9.4.1.1}]$$

$$P_n = [0.658^{(P_o/P_e)}] P_o = 592 \text{ kips} \quad [\text{AASHTO-LRFD 6.9.4.1.1}]$$

$$\phi_c P_n = (0.90)(592) = 533 \text{ kips} > [P_u = 143 \text{ kips}] \text{ OK}$$

By inspection, the slenderness ratio after check scour and pile axial resistance will be acceptable at the Extreme Event II limit state.

The lateral load for a pile is within the limit set in BDM Table 6.2.6.1-2, and no further lateral analysis is required.

$$V_u = 5 \text{ kips} < [\phi_v V_n = (1.00)(18) = 18 \text{ kips}] \text{ OK}$$

(The service limit state, not illustrated in this example, may control because of the traditional Bridges and Structures Bureau limit of 6 kips [BDM Table 6.2.6.1-2] combined with lateral loads in Service I and the 1.0 load factor on temperature. Lateral deflections and rotations also may need to be checked in some cases.)

These computations need to be modified for non-typical conditions such as absence of battered piles, significant water or ice loads, and very soft soils immediately below scour elevations.

Step 4 - Estimate nominal friction and end bearing geotechnical resistance

Based on the Pier #1 soil boring and BDM Tables 6.2.7-1 and 6.2.7-2, the final design engineer estimates the following nominal resistances for friction and end bearing as shown in the table below.

Track 1, Example 2-estimated nominal geotechnical resistance

Soil Stratum	Soil Description	Stratum Thickness (ft)	Average SPT N Value (blows/ft)	Estimated Nominal Resistance for Friction Pile (kips/ft)	Cumulative Nominal Friction Resistance at Bottom of Layer ⁽¹⁾ (kips)	Estimated Nominal Resistance for End Bearing (ksi)
1A	Silty Sand above Scour Elevation	10	5	1.2	12	---
1	Silty Sand below Scour Elevation	23	3	1.2	40	---
2	Firm Silty Clay	13	10	2.0	66	---
3	Very Firm Glacial Clay (more than 30 feet below the natural ground elevation)	44	21	4.0	242	---
3	Very Firm Glacial Clay	---	21 ⁽²⁾	---	---	1

(1) This information is used to prepare the calculations in Step 7.

(2) The SPT N value for Layer 3 is near the lower limit for use of end bearing.

Step 5 - Select resistance factor to estimate pile length based on the soil profile and construction control

By inspection, more than 30 percent and less than 70 percent of the embedded pile length will be

in non-cohesive soil, and hence the soil over the pile embedment length is generalized as a mixed soil.

For driven H-pile with construction control based on a WEAP analysis at EOD and no planned retap, the following resistance factor is recommended to estimate the contract pile length for mixed soil [BDM Table 6.2.9-1].

$\phi = 0.65$ for mixed soil, averaged over the full depth of estimated pile penetration

Step 6 - Calculate the required nominal pile resistance, R_n

The required nominal pile resistance can be calculated as:

$$R_n = \frac{\sum \eta \gamma Q + \gamma_{DD} DD}{\phi} = \frac{143 + 0}{0.65} = 220 \text{ kips/pile}$$

where

$$\sum \eta \gamma Q = \gamma Q = 143 \text{ kips (Step 3)}$$

$$\gamma_{DD} DD = 0 \text{ (no downdrag)}$$

$$\phi = 0.65 \text{ (Step 5)}$$

Step 7 – Estimate contract pile length, L, considering scour

Based on the nominal resistance values in Step 4, the cumulative nominal geotechnical resistance, R_{n-BB} , per pile is calculated as follows, where D = depth in feet below the bottom of footing.

$$D_0 = 0 \text{ ft, } R_{n-BB0} = 0 \text{ kips}$$

$$D_1 = 10 \text{ ft, } R_{n-BB1} = R_{n-BB0} + 0 = 0 \text{ kips because scour zone provides no support}$$

$$D_2 = 10 + 23 = 33 \text{ ft, } R_{n-BB2} = R_{n-BB1} + (1.2 \text{ kips/ft}) (23 \text{ ft}) = 0 + 27.6 = 27.6 \text{ kips}$$

$$D_3 = 33 + 13 = 46 \text{ ft, } R_{n-BB3} = R_{n-BB2} + (2.0 \text{ kips/ft}) (13 \text{ ft}) = 27.6 + 26.0 = 53.6 \text{ kips}$$

$$\text{End bearing in Layer 3} = (1 \text{ ksi})(16.8 \text{ in}^2) = 16.8 \text{ kips, } R_{n-BB4} = R_{n-BB3} + 16.8 = 70.4 \text{ kips}$$

$$\text{Required additional length in Layer 3} = (220 - 70.4)/4.0 = 37 \text{ feet}$$

$$D_4 = 46 + 37 = 83 \text{ ft,}$$

$$R_{n-BB5} = R_{n-BB4} + (4.0 \text{ kips/ft}) (37 \text{ ft}) = 70.4 + 148.0 = 218.4 \text{ kips} \approx 220 \text{ kips}$$

The contract pile length includes a 1-foot embedment in the footing [BDM Table 6.2.5] and a 1-foot allowance for cutoff due to driving damage [BDM 6.2.4.2].

$$L = 83 + 1 + 1 = 85 \text{ feet}$$

The length for steel H-piles is specified in 5-foot increments [BDM 6.2.4.2]. Since the contract pile length is already at an even 5-foot increment, the contract pile length does not need to be

rounded to the nearest 5-foot increment.

At this point the embedded pile length is known, and it is necessary to check the site classification for the resistance factor.

$$\begin{aligned} \text{\% non-cohesive soil below scour elevation} &= [23/(83-10)](100) = \\ 31.5\% &> 30\% \text{ and } < 70\% \end{aligned}$$

Therefore, the resistance factor for mixed soil is the correct choice.

Step 8 - Estimate target nominal pile driving resistance, $R_{\text{ndr-T}}$

The complete embedment length below the bottom of footing will contribute to pile driving resistance, i.e., the soil resistance above scour elevation which was ignored in Step 4 should be considered in pile driving resistance, $R_{\text{ndr-T}}$.

The complete pile embedment length is 83 feet, which is equal to the 85-foot contract pile length minus the 1 foot of embedment length in the concrete footing and the 1 foot cutoff.

The H-pile will penetrate 33 feet of non-cohesive soil below the bottom of footing.

$$\text{\% non-cohesive soil} = [33/83] (100) = 40\% > 30\%$$

Therefore, the generalized soil category for pile driving (construction stage) is also "mixed". It should be noted that it is possible for piles for a substructure to have different soil categories during the design stage and during construction stage.

For driven H-pile with WEAP analysis construction control and no planned retap, the following resistance factor, ϕ_{TAR} , is recommended to estimate the target pile driving resistance at end of drive (EOD) for mixed soil [BDM Table 6.2.9-3].

$\phi_{\text{TAR}} = 0.65$ for mixed soil, averaged over the full depth of estimated pile penetration

$$R_{\text{SCOUR}} = (1.2 \text{ kip/ft})(10 \text{ ft}) = 12 \text{ kips}$$

$$\begin{aligned} R_{\text{ndr-T}} &= \frac{\sum \eta \gamma Q + \gamma_{\text{DD}} D D}{\phi_{\text{TAR}}} + R_{\text{SCOUR}} \\ &= \frac{143 + 0}{0.65} + 12 \\ &= 220 + 12 = 232 \text{ kips/pile} = 116 \text{ tons/pile} \end{aligned}$$

Step 9 – Prepare CADD notes for the bridge plans

At this point the final design engineer selects the appropriate CADD notes and adds the specific

pile load values to the notes [BDM 13.8.2].

E718: Pier piles, LRFD contract length and resistance

THE CONTRACT LENGTH OF 85 FEET FOR THE PIER #1 PILES IS BASED ON A MIXED SOIL CLASSIFICATION, A TOTAL FACTORED AXIAL LOAD PER PILE (P_U) OF 143 KIPS, AND A GEOTECHNICAL RESISTANCE FACTOR (ϕ) OF 0.65 FOR SOIL.

THE NOMINAL AXIAL BEARING RESISTANCE FOR CONSTRUCTION CONTROL WAS DETERMINED FROM A MIXED SOIL CLASSIFICATION AND A GEOTECHNICAL RESISTANCE FACTOR (ϕ) OF 0.65 FOR SOIL. PILES ARE ASSUMED TO BE DRIVEN FROM A START ELEVATION AT THE BOTTOM OF FOOTING. DESIGN SCOUR (200-YEAR) WAS ASSUMED TO AFFECT THE UPPER 10 FEET OF EMBEDDED PILE LENGTH AND CAUSE 12 KIPS OF DRIVING RESISTANCE.

E719: Pier piles, LRFD driving and construction control

THE REQUIRED NOMINAL AXIAL BEARING RESISTANCE FOR PIER #1 PILES IS 116 TONS AT END OF DRIVE OR RETAP. THE PILE CONTRACT LENGTH SHALL BE DRIVEN AS PER PLAN UNLESS PILES REACH REFUSAL. CONSTRUCTION CONTROL REQUIRES A WEAP ANALYSIS AND BEARING GRAPH.

Note that a statement about retaps was included in the driving note, since the piling will be driven in a mixed soil classification. Setup gain is ignored for mixed soil.

Step 10 – Check the design

Within the Bridges and Structures Bureau at the Iowa DOT a final design engineer other than the bridge designer is assigned to give the bridge design an independent check at the time final plans are complete. During the checking process a final design engineer will review the soils package to ensure that all recommendations were followed and also will check structural, geotechnical, and drivability aspects of the design.

Other design organizations may perform checks at various stages of design rather than upon plan completion.

-----**END DESIGN PHASE**-----

-----**BEGIN CONSTRUCTION PHASE**-----

Step 11 – Request and check contractor’s hammer data, and prepare bearing graph for WEAP control

After the bridge contract is let and prior to start of pile driving, the contractor completes Hammer

Data sheets for the pile driving hammer that he/she plans to use. The Hammer Data sheets include all pertinent information including the cap (helmet) number and hammer identification information with details, hammer cushion, and pile cushion (where required), as well as pile size, pile length, and estimated pile driving resistance. The Construction and Materials Bureau uses the data received to complete a WEAP analysis for construction control during pile driving. Results from the WEAP analysis are then used to prepare an LRFD Bearing Graph (without the factor of safety used for allowable stress design). The Bearing Graph includes curves of nominal driving resistance versus blows per foot, and identifies specific driving conditions, where driving stress is a concern.

Step 12 - Observe construction, record driven resistance, and resolve any construction issues

If the recorded pile driving resistance at EOD is less than the target pile nominal driving resistance, then the pile is retapped about 24 hours after EOD. (The retap is a remedial measure that makes use of setup for an individual pile. If the 24-hour retap does not indicate enough driven resistance, an extension will be added the same day rather than wait to retap another day.)

Track 1, Example 3

Driven H-Pile in Cohesive Soil with Downdrag, and Construction Control Based on Wave Equation and No Planned Retap (*)

(*) On January 1, 2016 per BDM 6.2.4.6 the Bureau recommended the beneficial effects of setup be neglected in the determination of the target nominal pile driving resistance when downdrag is present. This example was not updated to reflect that recommendation.

General design and construction steps to be modified for project conditions

Design Steps	
Step 1	Develop bridge situation plan (or TS&L, Type, Size, and Location). ⁽¹⁾
Step 2	Develop soils package, including soil borings and foundation recommendations. ⁽¹⁾
Step 3	Determine pile layout, pile loads including downdrag, and other design requirements. ⁽¹⁾ This step includes structural checks.
Step 4	Estimate nominal geotechnical resistance for friction and end bearing.
Step 5	Select resistance factor(s) to estimate pile length based on the soil profile and construction control.
Step 6	Calculate required nominal pile resistance, R_n .
Step 7	Estimate contract pile length, L , considering downdrag, scour, pile uplift, lateral loading, and unbraced length, if applicable.
Step 8	Estimate target nominal pile driving resistance, R_{ndr-T} .
Step 9	Prepare CADD notes for bridge plans.
Step 10	Check the design. ⁽²⁾
Construction Steps	
Step 11	Request and check contractor's hammer data, and prepare bearing graph for WEAP control or other necessary items for alternate methods of construction control.
Step 12	Observe construction, record driven resistance, and resolve any construction issues.

(1) These steps determine the basic information for geotechnical pile design and will vary depending on bridge project and Bureau practice.

(2) Checking will vary depending on bridge project and Bureau practice.

Within the Bridges and Structures Bureau at the Iowa DOT the design steps that determine the basic information necessary for design of a steel H-pile generally follow as indicated in Steps 1-3. The steps involve communication among the preliminary design engineer, soils design engineer, and final design engineer. In other organizations the basic information may be determined differently, but that process generally should not affect the overall design of the pile.

Step 1 - Develop bridge situation plan (or TS&L, Type, Size, and Location)

For a typical bridge the preliminary design engineer plots topographical information, locates the bridge, determines general type of superstructure, location of substructure units, elevations of foundations, hydraulic information (if needed), and other basic information to characterize the bridge. The preliminary design engineer then prepares a TS&L sheet that shows a plan and longitudinal section of the bridge.

For this example, for a state project, the TS&L gives the following information needed for design of abutment piles:

- 120-foot single span, prestressed concrete beam superstructure
- Zero skew
- Integral abutments (because these are standard practice for non-skewed concrete bridges less than 575 feet in length with end or single spans not exceeding the length of standard prestressed concrete beams) [BDM 6.5.1.1.1]
- Pile foundations
- Bottom of abutment footing elevation 435 feet

Step 2 - Develop soils package, including soil borings and foundation recommendations

Based on locations of the abutments the soils design engineer orders soil borings, typically at least one per substructure unit. When the engineer receives the boring logs he/she arranges for them to be plotted on a longitudinal section, checks any special geotechnical conditions on the site, and writes a recommendation for foundation type with any applicable special design considerations.

For this example, the recommendations are the following:

- Downdrag due to consolidation settlement in the soft silty clay layer, with neutral plane at the top of the firm silty clay layer
- Friction piles with end bearing that tip out in the very firm glacial clay layer
- Steel H-piles for the integral abutments
- Structural Resistance Level – 1 (which does not require a driving analysis by the Construction and Materials Bureau during design [BDM 6.2.6.1]) Beginning on January 1, 2016 designers may increase the nominal structural pile resistance from SRL-1 to SRL-1.5 for steel H-piles at abutments with downdrag. See BDM 6.2.2.2 and 6.2.6.1 for additional information. Note that this example was not updated to reflect this policy.
- Normal driving resistance (This will lead to $\phi_c = 0.60$ for the structural check.)
- No special site considerations for stability, settlement, or lateral movement (Therefore a Service I load will not be required for design.)
- Standard construction control based on WEAP analysis with no planned retap

The soil profile shown below includes the soil boring at the west abutment. Generally below the bottom of footing elevation the three layers are: 33 feet of soft silty clay, 13 feet of firm silty sand, and very firm glacial clay to the bottom of the boring at 115 feet.

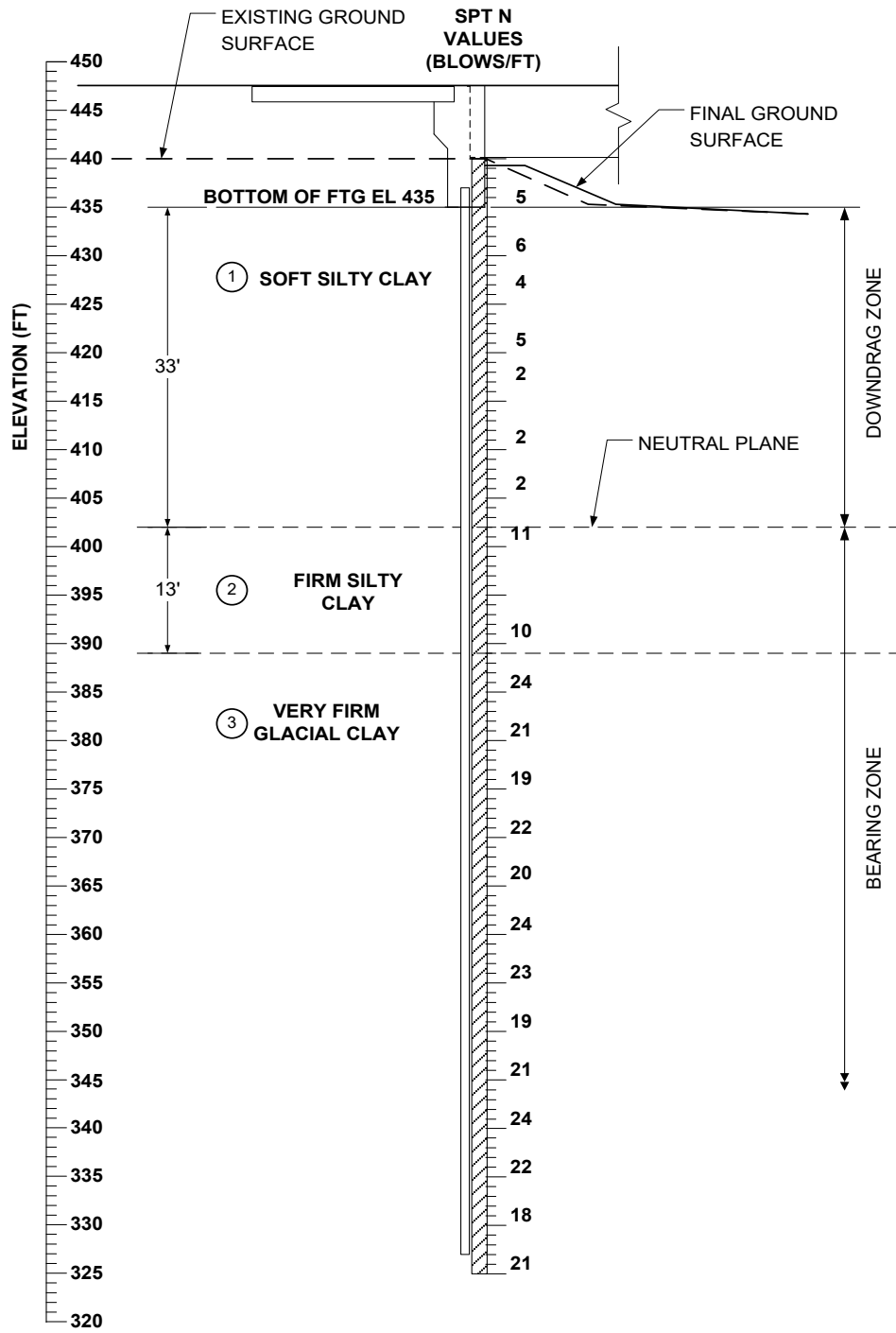

Track 1, Example 3-soil profile at west abutment

Step 3 - Determine pile layout, pile loads including downdrag, and other design requirements. This step includes structural checks.

The final design engineer begins design of the abutment piles with the TS&L and the soils design package. Because the bridge has a prestressed concrete beam superstructure and integral abutments the engineer selects HP 10×57 piles, following Bridge Design Manual policy [BDM 6.5.1.1.1].

Approximately 8 feet of embankment will be placed behind the abutment, and the soft silty clay layer is susceptible to consolidation settlement as noted by the soils design engineer. Therefore, the neutral plane is at the bottom of the soft silty clay. Soil above the neutral plane is in the "Downdrag Zone". Soil below the neutral plane is in the "Bearing Zone". Pile nominal resistance should be based on the resistance from the Bearing Zone, only. Soil in the Downdrag Zone induces downdrag load ($\gamma_{DD}DD$) on pile, in addition to the loads from the superstructure ($\sum\eta\gamma P$).

Although the bridge length is less than 130 feet and would not require prebored holes for the integral abutment piles [BDM 6.5.1.1.1], in this case the final design engineer has received permission to use 15-foot prebored holes to relieve part of the downdrag force. The permission involved consultation with the final bridge section leader.)

Notation: The same loads are designated in Step 3 with "P" and in Steps 6 and 8 with "Q".

For the west abutment

$$\sum\eta\gamma P + \gamma_{DD}DD = 923 + (1.00)(DD) = P_u$$

Downdrag load (DD) in the Layer 1 soft silty clay will result from the clay below the bottom of the prebore over $33-15 = 18$ feet. Average SPT N-value is about 3, and the unit nominal resistance is 1.2 kips/foot [BDM Table 6.2.7-2]. [Note - the unit nominal resistance for an HP10x57 pile in this soft silty clay layer with an average SPT N-value of 3 would be better approximated by 0.8 kips/foot; however, 1.2 kips/foot will continue to be used in this example.]

$$DD = (18)(1.2) = 22 \text{ kips (rounded)}$$

The soils package indicates normal driving resistance, therefore

$$\phi_c = 0.60$$

The soils engineer recommends SRL-1 for which

$$P_n = 243 \text{ kips [BDM Table 6.2.6.1-1]}$$

Beginning on January 1, 2016 designers may increase the nominal structural pile resistance from SRL-1 to SRL-1.5 for steel H-piles at abutments with downdrag. See BDM 6.2.2.2 and 6.2.6.1 for additional information. Note that this example was not updated to reflect this policy.

Considering the TS&L and other project factors the final design engineer selects BTC beams

[BDM Table 5.4.1.1.1]. For integral abutments with BTC beams and 15-foot prebored holes for the piles, the maximum $P_n = 365$ kips [BDM Table 6.5.1.1.1-1]. The SRL-1 recommendation controls, however.

Required number of piles with downdrag

$$n = P_u / \phi P_n = (923 + n[1.00][22]) / (0.60)(243), \quad 123.8n = 923, \quad n = 7.46$$

(If the soils information is not available at this point, the final designer may determine the number of piles at the SRL-1 limit without downdrag. Later when the soils information is available, the designer may add the downdrag amount to each pile if the extra load is below the SRL-1.5 limit per BDM 6.2.2.2 and 6.2.6.1 or may add one or more piles to the abutment. The SRL-1.5 limit was introduced on January 1, 2016.)

Based on the overall project the final design engineer rounds down in this case to 7 piles and discusses the decision with the soils engineer and supervising section leader. The integral abutment maximum $P_n = 365$ kips is at SRL-2 so there is additional resistance available above SRL-1.

Without downdrag the Strength I load per pile (needed for Step 6) then is

$$P_u = 923 / 7 = 132 \text{ kips/pile}$$

The pile layout will be seven piles under the abutment plus one pile for each wing extension as shown below. (For the number of beams the designer checks the minimum number of piles, and for the abutment dimensions the designer checks the pile spacing guidelines [BDM 6.2.4.1]. Those checks are not shown here.) In this case the wing extension piles are added for abutment stability and are moderately loaded so they need not be checked for structural resistance.

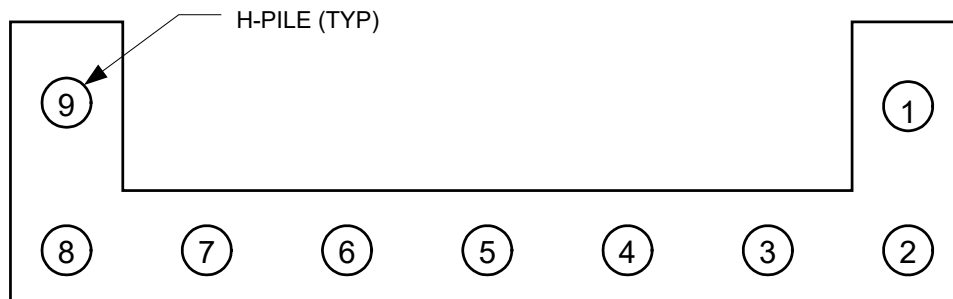

Track 1, Example 3-pile layout at west abutment

Step 4 - Estimate nominal geotechnical resistance for friction and end bearing

Based on the west abutment soil boring and BDM Tables 6.2.7-1 and 6.2.7-2, the final design engineer estimates the following nominal resistances for friction and end bearing as shown in the table below.

Track 1, Example 3-estimated nominal geotechnical resistance

Soil Stratum	Soil Description	Stratum Thickness (ft)	Average SPT N Value (blows/ft)	Estimated Nominal Resistance for Friction Pile (kips/ft)	Cumulative Nominal Friction Resistance at Bottom of Layer ⁽¹⁾ (kips)	Estimated Nominal Resistance for End Bearing (kips/sq in)
1	Soft Silty Clay	18 below prebore	3	1.2	22	---
2	Firm Silty Clay	13	10	2.0	48	---
3	Very Firm Glacial Clay (30 feet below the natural ground elevation)	64	21	4.0	304	---
3	Very Firm Glacial Clay	---	21 ⁽²⁾	---	---	1

(1) This information is used to develop the calculations in Step 7.

(2) The SPT N value for Layer 3 is near the lower limit for use of end bearing.

Step 5 - Select resistance factor to estimate pile length based on the soil profile and construction control

For a driven H-pile with construction control based on a WEAP analysis at EOD and no planned retap, the following resistance factor is recommended to estimate the contract pile length for cohesive soil [BDM Table 6.2.9-1]. Only cohesive soil was present below the west abutment.

$\phi = 0.65$ for cohesive soil, averaged over the full depth of estimated pile penetration

Step 6 - Calculate required nominal pile resistance, R_n

As mentioned in Step 3, in calculating required nominal pile resistance, downdrag load should be accounted for in addition to the loads from the superstructure. The required nominal pile resistance is:

$$\begin{aligned} R_n &= \frac{\sum \eta \gamma Q}{\phi} + \frac{\gamma_{DD} DD}{\phi} \\ &= \frac{132}{0.65} + \frac{(1.0)(22)}{0.65} \\ &= 203 + 34 \\ &= 237 \text{ kips/pile} \end{aligned}$$

where,

$$\sum \eta \gamma Q = \gamma Q \text{ (Step 3)}$$

with $\eta = 1.0$ from BDM 6.2.3.1

$$\gamma Q = 132 \text{ kips (Step 3)}$$

$$\gamma_{DD} = 1.0 \text{ per BDM 6.2.4.3}$$

DD = downdrag load caused by consolidation or deformation of a soft cohesive soil layer over a stiff layer, which is estimated using the BDM Table 6.2.7-2 as shown in Steps 3 and 4 = 22 kips

$$\phi = 0.65 \text{ (Step 5)}$$

Step 7 – Estimate contract pile length, L , considering downdrag

Based on the nominal resistance values in Step 4, the cumulative nominal geotechnical resistance, R_{n-BB} , per pile is calculated as follows, where D = depth in feet below the bottom of footing.

$$D_0 = 0 \text{ ft, } R_{n-BB0} = 0 \text{ kips}$$

$$D_1 = 33 \text{ ft, } R_{n-BB1} = R_{n-BB0} + 0 = 0 \text{ kips because downdrag zone provides no support}$$

$$D_2 = 33 + 13 = 46 \text{ ft, } R_{n-BB2} = R_{n-BB1} + (2.0 \text{ kips/ft})(13 \text{ ft}) = 0 + 26.0 = 26.0 \text{ kips}$$

$$\text{End bearing in Layer 3} = (1 \text{ ksi})(16.8 \text{ in}^2) = 16.8 \text{ kips, } R_{n-BB3} = R_{n-BB2} + 16.8 = 42.8 \text{ kips}$$

$$\text{Required additional length in Layer 3} = (237 - 42.8)/4.0 = 49 \text{ feet}$$

$$D_3 = 46 + 49 = 95 \text{ ft, } R_{n-BB4} = R_{n-BB3} + (4.0 \text{ kips/ft})(49 \text{ ft}) = 42.8 + 196.0$$

$$= 238.8 \text{ kips} > 237 \text{ kips}$$

The contract pile length includes a 2-foot embedment in the footing and a 1-foot allowance for

cutoff due to driving damage.

$$L = 95 + 2 + 1 = 98 \text{ feet}$$

The length for steel H-piles is specified in 5-foot increments [BDM 6.2.4.2]. Therefore, the contract pile length is rounded to 100 feet.

Because the site has only cohesive soil within the embedded length of the pile, the resistance factor determined in Step 5 need not be checked for site classification.

Step 8 - Estimate target nominal pile driving resistance, $R_{\text{ndr-T}}$

The complete embedment length below the bottom of footing except for the prebored hole will contribute to pile driving resistance, i.e., resistance from the soil above the neutral plane needs to be accounted for during pile driving. The pile embedment length is 82 feet, which is equal to the 100-foot contract pile length minus a 1-foot cutoff, 2 feet of embedment length in the concrete footing, and 15 feet of prebored hole.

On January 1, 2016 per BDM 6.2.4.6 the Bureau recommended the beneficial effects of setup be neglected in the determination of $R_{\text{ndr-T}}$ when downdrag is present. This example was not updated to reflect that recommendation.

For driven H-pile with WEAP analysis construction control and no planned retap, the following resistance factors, ϕ , are recommended to estimate the target nominal pile driving resistance for cohesive soils [BDM Table 6.2.9-3].

$\phi_{\text{EOD}} = 0.65$ for cohesive soil, averaged over the full depth of estimated pile penetration

$\phi_{\text{SETUP}} = 0.20$ for cohesive soil, averaged over the full depth of estimated pile penetration

It should be noted that the generalized soil category for both design stage and construction stage are the same, since only cohesive soils are encountered at this location. For piles penetrating both cohesive soils and non-cohesive soils, a separate generalized soil category is needed here, because the soil below prebored depth and above the neutral plane should be considered in pile driving resistance for construction stage, and this may result in a change in the generalized soil category and consequently the resistance factor.

At EOD, the factored target nominal resistance should overcome the factored target nominal resistance from the downdrag zone, in addition to the factored loads (loads from superstructure + downdrag load):

$$\sum \eta\gamma Q + \gamma_{\text{DD}} \text{DD} = \phi_{\text{TAR}} R_{\text{ndr-T}} - \phi_{\text{TAR}} R_{\text{Sdd}}$$

where, R_{Sdd} = Nominal driving resistance that accounts for the downdrag load estimated in Steps 4 and 6, which is equal to DD.

ϕ_{TAR} = Resistance factor for target nominal resistance

$$= \varphi_{EOD} + \varphi_{SETUP}(F_{SETUP} - 1) \leq 1.00$$

and F_{SETUP} = Setup Factor.

The soil profile was used to calculate the average SPT N-value for cohesive soil penetrated by the driven pile over the contract pile length, as follows.

$$\text{Calculated average SPT N-value} = [(18')(4) + (13')(10) + (97'-33'-13')(21)]/(97'-15') = 16$$

Based on the pile setup factor chart shown below the average SPT N-value of 16 yields Setup Factors, F_{SETUP} , of 1.45 for 1-day retap, 1.53 for 3-day retap, and 1.58 for 7-day retap.

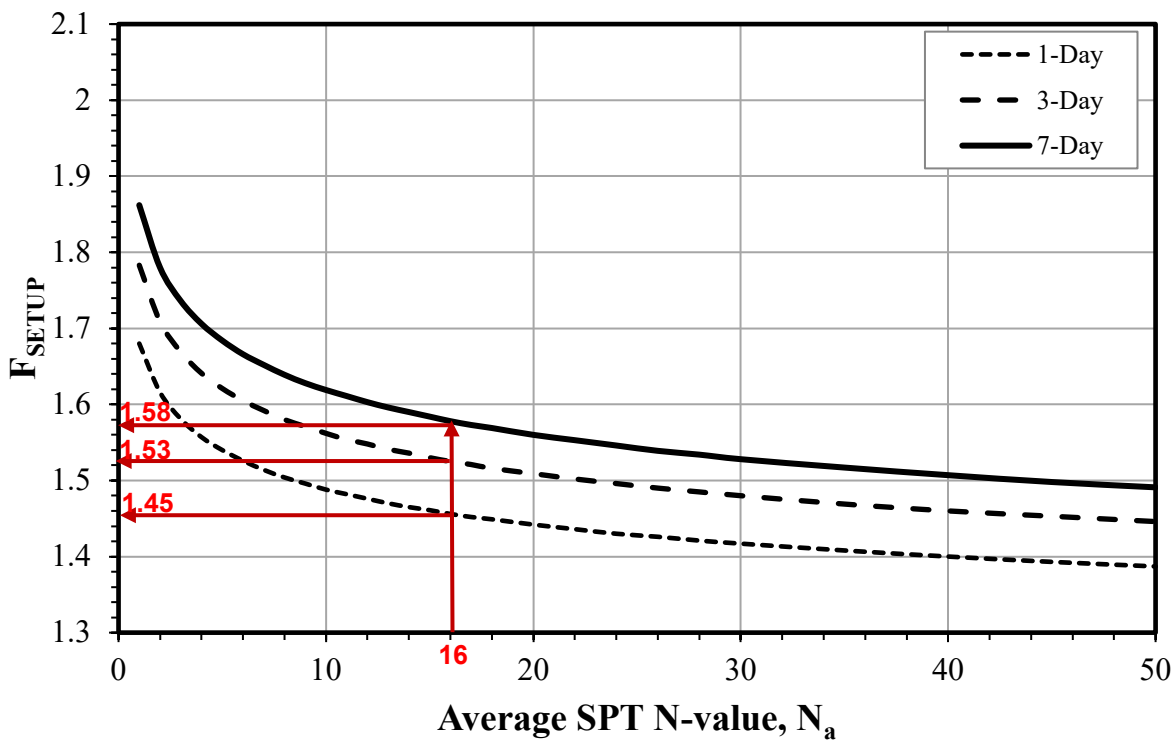

Track 1, Example 3-pile setup factor chart [BDM Figure 6.2.10]

The target pile driving resistance at End Of Drive is

$$\begin{aligned} R_{ndr-T} &= \frac{\sum \eta \gamma Q}{\varphi_{TAR}} + \frac{\gamma_{DD} DD}{\varphi_{TAR}} + R_{Sdd,EOD} \\ &= \frac{\sum \eta \gamma Q}{\varphi_{EOD} + \varphi_{SETUP}(F_{SETUP} - 1)} + \frac{\gamma_{DD} DD}{\varphi_{EOD} + \varphi_{SETUP}(F_{SETUP} - 1)} + R_{Sdd} \\ &= \frac{132}{(0.65) + (0.20)(1.58 - 1)} + \frac{(1.0)(22)}{(0.65) + (0.20)(1.58 - 1)} + 22 \end{aligned}$$

$$= \frac{132}{0.77} + \frac{22}{0.77} + 22$$

Note that $\phi_{TAR} < 1.00$, OK

$$= 173 + 29 + 22$$

$$= 224 \text{ kips/pile} = 112 \text{ tons/pile}$$

The target nominal geotechnical resistance at 1-day retap then is:

$R_{1\text{-day}} = (173+29)(1.45)+22 = 314.9 \text{ kips} = 157 \text{ tons}$, but not more than $R_{\text{ndr-T}}$ computed with ϕ_{EOD} , not considering setup.

$$R_{1\text{-day}} \leq (132 + 22)/0.65 + 22 = 258.9 \text{ kips} = 129 \text{ tons}$$

The 129 tons controls at 1-day retap.

The target nominal geotechnical resistance at 3-day retap then is:

$R_{3\text{-day}} = (173+29)(1.53)+22 = 331.1 \text{ kips} = 166 \text{ tons}$, but not more than $R_{\text{ndr-T}}$ computed with ϕ_{EOD} , not considering setup.

The 129 tons also controls at 3-day retap.

The target nominal geotechnical resistance at 7-day retap then is:

$R_{7\text{-day}} = (173+29)(1.58)+22 = 341.2 \text{ kips} = 171 \text{ tons}$, but not more than $R_{\text{ndr-T}}$ computed with ϕ_{EOD} , not considering setup.

The 129 tons also controls at 7-day retap.

Step 9 – Prepare CADD notes for the bridge plans

At this point the final design engineer selects the appropriate CADD notes and adds the specific pile load values to the notes [BDM 13.8.2].

E818: Abutment piles, LRFD contract length and resistance

THE CONTRACT LENGTH OF 100 FEET FOR THE WEST ABUTMENT PILES IS BASED ON A COHESIVE SOIL CLASSIFICATION, A TOTAL FACTORED AXIAL LOAD PER PILE (P_U) OF 154 KIPS, AND A GEOTECHNICAL RESISTANCE FACTOR (ϕ) OF 0.65. TO ACCOUNT FOR SOIL CONSOLIDATION UNDER THE NEW FILL, THE FACTORED AXIAL LOAD INCLUDES A FACTORED DOWNDRAAG LOAD OF 22 KIPS.

THE NOMINAL AXIAL BEARING RESISTANCE FOR CONSTRUCTION

CONTROL WAS DETERMINED FROM A COHESIVE SOIL CLASSIFICATION AND A GEOTECHNICAL RESISTANCE FACTOR (PHI) OF 0.77. PILES ARE ASSUMED TO BE DRIVEN FROM A START ELEVATION AT THE BOTTOM OF PREBORE.

E819: Abutment piles, driving and construction control

THE REQUIRED NOMINAL AXIAL BEARING RESISTANCE FOR WEST ABUTMENT PILES IS 112 TONS AT END OF DRIVE (EOD). IF RETAPS ARE NECESSARY TO ACHIEVE BEARING, THE REQUIRED NOMINAL AXIAL BEARING RESISTANCE IS 129 TONS AT ONE-DAY OR LATER RETAP. THE PILE CONTRACT LENGTH SHALL BE DRIVEN AS PER PLAN UNLESS PILES REACH REFUSAL. CONSTRUCTION CONTROL REQUIRES A WEAP ANALYSIS WITH BEARING GRAPH.

Step 10 – Check the design

Within the Bridges and Structures Bureau at the Iowa DOT a final design engineer other than the bridge designer is assigned to give the bridge design an independent check at the time final plans are complete. During the checking process a final design engineer will review the soils package to ensure that all recommendations were followed and also will check structural, geotechnical, and drivability aspects of the design.

Other design organizations may perform checks at various stages of design rather than upon plan completion.

-----**END DESIGN PHASE**-----

-----**BEGIN CONSTRUCTION PHASE**-----

Step 11 – Request and check contractor’s hammer data, and prepare bearing graph for WEAP control

After the bridge contract is let and prior to start of pile driving, the contractor completes Hammer Data sheets for the pile driving hammer that he/she plans to use. The Hammer Data sheets include all pertinent information including the cap (helmet) number and hammer identification information with details, hammer cushion, and pile cushion (where required), as well as pile size, pile length, and estimated pile driving resistance. The Construction and Materials Bureau uses the data received to complete a WEAP analysis for construction control during pile driving. Results from the WEAP analysis are then used to prepare an LRFD Bearing Graph (without the factor of safety used for allowable stress design). The Bearing Graph includes curves of nominal driving resistance versus blows per foot, and identifies specific driving conditions, where driving stress is a concern.

Step 12 - Observe construction, record driven resistance, and resolve any construction issues

During pile driving, the construction inspector records the hammer stroke and number of blows

to advance the pile an equivalent penetration of 1 foot, and then converts the recorded information with the Bearing Graph to record the driven resistance per pile at EOD.

If the recorded pile driving resistance at EOD is less than the target pile nominal driving resistance, then the pile is retapped about 24 hours after EOD. (The retap is a remedial measure that makes use of setup for an individual pile. If the 24-hour retap does not indicate enough driven resistance, an extension will be added the same day rather than wait to retap another day.)

Track 1, Example 4

Driven H-Pile in Sand with Uplift Load, and Construction Control Based on Wave Equation and No Planned Retap

General design and construction steps to be modified for project conditions

Design Steps	
Step 1	Develop bridge situation plan (or TS&L, Type, Size, and Location). ⁽¹⁾
Step 2	Develop soils package, including soil borings and foundation recommendations. ⁽¹⁾
Step 3	Determine pile layout, pile loads including downdrag, and other design requirements. ⁽¹⁾ This step includes structural checks.
Step 4	Estimate nominal geotechnical resistance for friction and end bearing.
Step 5	Select resistance factor(s) to estimate pile length based on the soil profile and construction control.
Step 6	Calculate required nominal pile resistance, R_n .
Step 7	Estimate contract pile length, L , considering downdrag, scour, pile uplift, lateral loading, and unbraced length, if applicable.
Step 8	Estimate target nominal pile driving resistance, R_{ndr-T} .
Step 9	Prepare CADD notes for bridge plans.
Step 10	Check the design. ⁽²⁾
Construction Steps	
Step 11	Request and check contractor's hammer data, and prepare bearing graph for WEAP control or other necessary items for alternate methods of construction control.
Step 12	Observe construction, record driven resistance, and resolve any construction issues.

(1) These steps determine the basic information for geotechnical pile design and will vary depending on bridge project and Bureau practice.

(2) Checking will vary depending on bridge project and Bureau practice.

Within the Bridges and Structures Bureau at the Iowa DOT, the design steps that determine the basic information necessary for design of a steel H-pile generally follow as indicated in Steps 1-3. The steps involve communication among the preliminary design engineer, soils design engineer, and final design engineer. In other organizations the basic information may be determined differently, but that process generally should not affect the overall design of the pile.

Step 1 - Develop bridge situation plan (or TS&L, Type, Size, and Location)

For a typical bridge the preliminary design engineer plots topographical information, locates the bridge, determines general type of superstructure, location of substructure units, elevations of foundations, hydraulic information (if needed), and other basic information to characterize the bridge. The preliminary design engineer then prepares a TS&L sheet that shows a plan and longitudinal section of the bridge.

For this example, for a state project, the TS&L gives the following information needed for design of the frame pier piles:

- 208-foot three span, prestressed concrete beam superstructure
- Zero skew
- Frame piers
- Pile foundation
- Bottom of pier footing elevation 435 feet
- No stream near pier

Step 2 - Develop soils package, including soil borings and foundation recommendations

Based on location of the bridge abutments and piers the soils design engineer orders soil borings, typically at least one per substructure unit. When the engineer receives the boring logs he/she arranges for them to be plotted on a longitudinal section, checks any special geotechnical conditions on the site, and writes a recommendation for foundation type with any applicable special geotechnical design considerations.

For this example, the recommendations are the following:

- Friction piles with end bearing that tip out in the granular material layer
- Steel H-piles for the frame pier footings
- Structural Resistance Level – 1 (which does not require a driving analysis by the Construction and Materials Bureau during design) [BDM 6.2.6.1]
- Normal driving resistance (This will lead to $\phi_c = 0.6$ for the structural check.)
- No special site considerations for stability, settlement, or lateral movement (Therefore a Service I load will not be required for design.)
- Standard construction control based on WEAP analysis with no planned retap

Subsurface conditions at Pier #1 shown on the next page have been characterized based on a representative test boring, as indicated in the soil profile. Below the bottom of footing elevation, subsurface conditions generally consist of about 8 feet of fine sand, underlain by about 10 feet of coarse sand, 22 feet of gravelly sand, and deeper granular material. The test boring was terminated at a depth of 70 feet below the existing ground surface, and no ground water was reported to have been encountered at the test boring.

Note that for river bridges (not in this example) ground water may require additional analysis as discussed in BDM 6.2.7 as follows:

...In non-cohesive soil, groundwater can significantly reduce the effective stress and resulting nominal pile bearing resistance. This is of particular concern for a river bridge that is founded on friction piles driven in granular soil below the phreatic surface. In that case, the designer should consider performing a separate analysis that accounts for the effective overburden pressure, to verify that the estimated pile length based on the unit resistance values is reasonable.

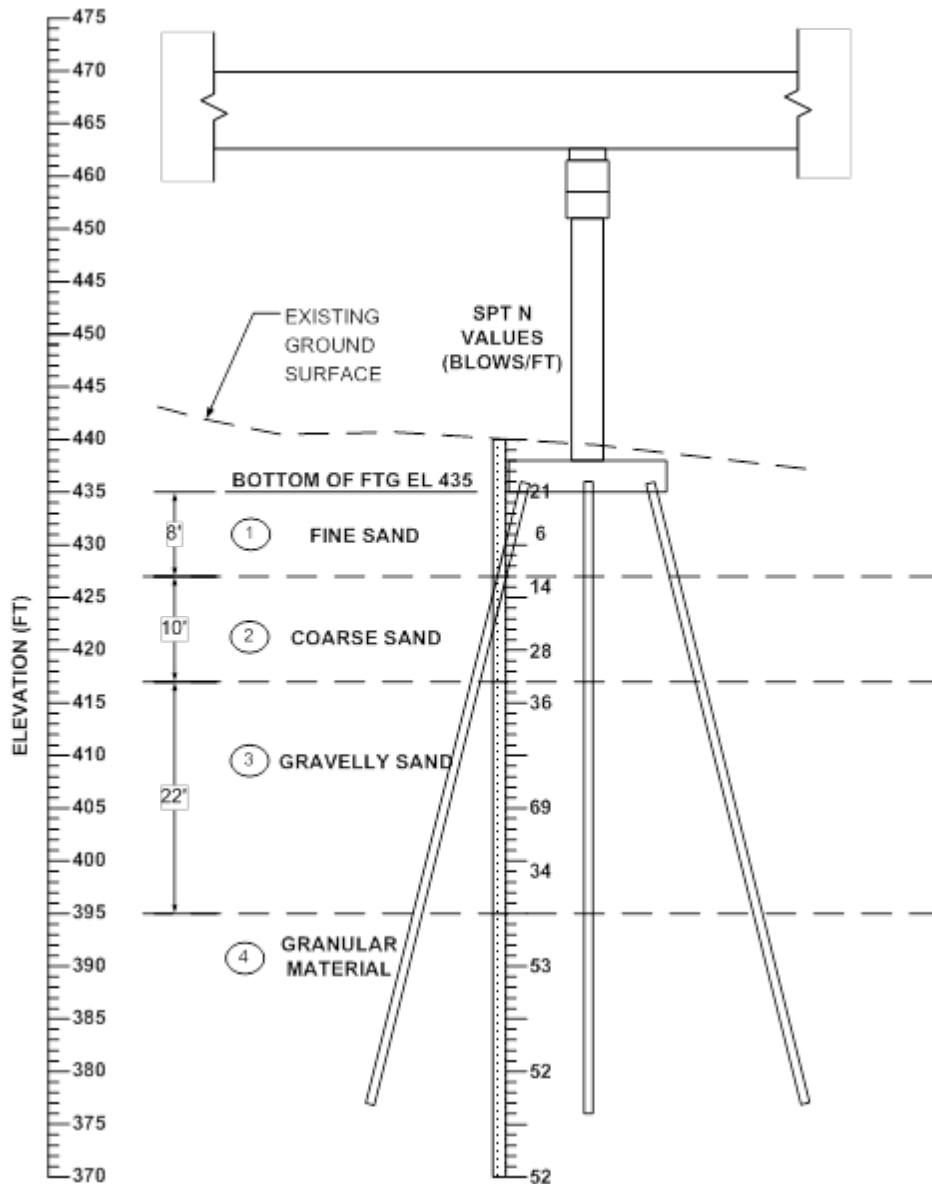

Track 1, Example 4-soil profile at Pier #1

Step 3 - Determine pile layout, pile loads, and other design requirements. This step includes structural checks.

The final design engineer begins design of the pier piles with the TS&L and the soils design package. Because the bridge has a prestressed concrete beam superstructure and integral abutments the engineer selects HP 10×57 piles for Pier #1 to match abutment piles, following Bridge Design Manual policy [BDM 6.5.1.1.1 and 6.2.1.1].

Based on RCPIER analysis at the strength limit state and Bridge Design Manual policy for pile spacing and number of piles [BDM 6.5.4.1.1], the final design engineer determines the

following:

- Nine Grade 50, HP 10×57 piles per each of three column footings as shown below
- Selected perimeter piles battered at 1:4, as indicated by the arrows shown below
- Maximum factored, compression load for one pile at the Strength I limit state = 132 kips
- Maximum factored, uplift load for one pile at the Strength III limit state = 40 kips
- Maximum factored, lateral load at the Strength III limit state = 4 kips

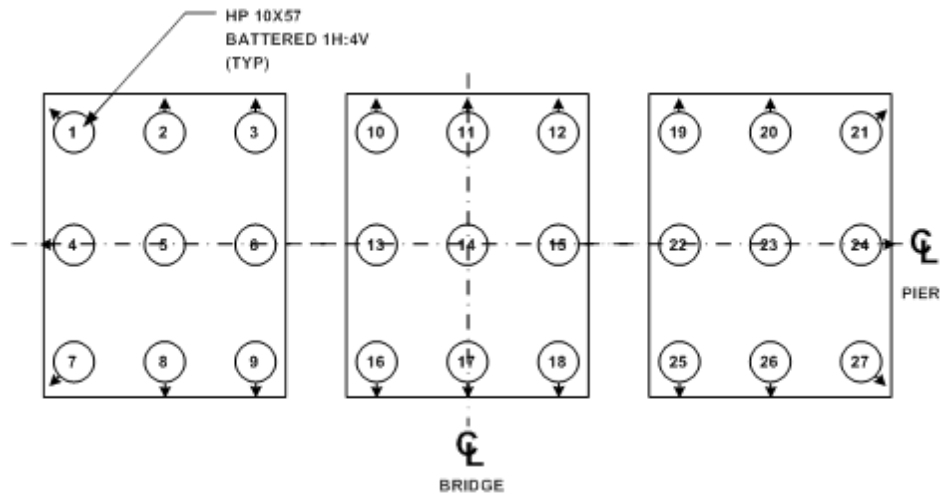

Track 1, Example 4-pile layout at Pier #1

Notation: The same loads are designated in Step 3 with “P” (for structural checks) and in Steps 6 and 8 with “Q” (for geotechnical and driving checks).

Check Structural Resistance Level – 1 (SRL-1) recommended by the soils engineer [BDM Table 6.2.6.1-1].

For a HP 10x57, $P_n = 243$ kips

The soils package indicates normal driving resistance, therefore

$$\phi_c = 0.60$$

Then

$$\phi_c P_n = (0.60)(243) = 146 \text{ kips} > [P_u = 132 \text{ kips}] \text{ OK}$$

The lateral load for a pile is within the limit set in BDM Table 6.2.6.1-2, and no further lateral analysis is required.

$$V_u = 4 \text{ kips} < [\phi_v V_n = (1.00)(18) = 18 \text{ kips}] \text{ OK}$$

The simple lateral load check needs to be modified for non-typical conditions, such as large lateral load or stringent lateral deflection limit.

By inspection, an HP 10x57 will have sufficient resistance for a factored tension load of 40 kips.

In Step 7 there will be a check to ensure that the pile will not pull out of the ground, but will it pull out of the footing?

The nominal resistance of an HP10 pile (or larger) with at least 12 inches of embedment in the concrete footing is 100 kips. The resistance factor for the strength limit state is $\phi = 0.25$. [BDM 6.2.6.1]. The factored uplift resistance for pile embedment in the concrete footing is:

$$(100 \text{ kips})(0.25) = 25 \text{ kips} < 40 \text{ kips} \quad \textbf{NOT Good.}$$

Therefore, one foot of embedment into the concrete footing is not sufficient to provide the required uplift resistance. The preferred solution then will be to use an approved anchorage methodology as found in BDM 6.2.6.1.

Step 4 - Estimate nominal friction and end bearing geotechnical resistance

Based on the pier soil boring and BDM Tables 6.2.7-1 and 6.2.7-2, the final design engineer estimates the following nominal resistances for friction and end bearing as shown in the table below.

Track 1, Example 4-estimated nominal geotechnical resistance

Soil Stratum	Soil Description	Stratum Thickness (ft)	Average SPT-N Value (blows/ft)	Estimated Nominal Resistance Value for Friction Pile (kips/ft)	Estimated Nominal Resistance Value for End Bearing Pile (kips/in ²)
1	Fine Sand	8	13	2.0	--- ⁽¹⁾
2	Coarse Sand	10	21	2.8	--- ⁽¹⁾
3	Gravelly Sand	22	35	2.8	3
4	Granular Material	---	52	4.0	4

(1) End bearing is not considered for fine sand, coarse sand, or gravelly sand with SPT-N value less than 25 blows/ft, per BDM Table 6.2.7-1.

Step 5 - Select resistance factors to estimate pile length based on the soil profile and construction control

For driven H-pile with construction control based on a WEAP analysis and no planned retap, the following resistance factor, ϕ , is recommended for use to estimate the contract pile length in non-

cohesive soil under axial compressive load [BDM Table 6.2.9-1].

$$\phi = 0.55 \text{ for non-cohesive soil}$$

For driven H-pile in axial tension under uplift load, the following resistance factors, ϕ_{UP} , are recommended for uplift check [BDM Table 6.2.9-2]. (Resistance factors for uplift are the resistance factors for compression with a reduction factor of 0.75.)

$$\phi_{UP} = 0.40 \text{ for non-cohesive soils at strength limit state.}$$

$$\phi_{UP} = 0.45 \text{ for cohesive and mixed soils at strength limit state.}$$

$$\phi_{UP} = 0.75 \text{ for non-cohesive, cohesive and mixed soils at extreme event limit state.}$$

Step 6 - Calculate required nominal pile resistance, R_n

The required nominal pile resistance in compression can be calculated as:

$$R_n = \frac{\sum \eta \gamma Q + \gamma_{DD} DD}{\phi} = \frac{132 + 0}{0.55} = 240 \text{ kips/pile}$$

where

$$\sum \eta \gamma Q = 132 \text{ kips (Step 3)}$$

$$\gamma_{DD} DD = 0 \text{ (no downdrag)}$$

$$\phi = 0.55 \text{ (Step 5)}$$

Step 7 – Estimate contract pile length, L , considering uplift

Based on the nominal resistance values in Step 4, the cumulative nominal compression geotechnical resistance, R_{n-BB} , per pile is calculated as follows, where D = depth in feet below the bottom of footing.

$$D_0 = 0 \text{ ft, } R_{n-BB0} = 0 \text{ kips}$$

$$D_1 = 8 \text{ ft, } R_{n-BB1} = R_{n-BB0} + (2.0 \text{ kips/ft}) (8 \text{ ft}) = 16.0 \text{ kips}$$

$$D_2 = 8 + 10 = 18 \text{ ft, } R_{n-BB2} = R_{n-BB1} + (2.8 \text{ kips/ft}) (10 \text{ ft}) = 16.0 + 28.0 = 44.0 \text{ kips}$$

$$D_3 = 18 + 22 = 40 \text{ ft, } R_{n-BB3} = R_{n-BB2} + (2.8 \text{ kips/ft}) (22 \text{ ft}) = 44.0 + 61.6 = 105.6 \text{ kips}$$

$$\text{End bearing in Layer 4} = (4 \text{ ksi})(16.8 \text{ in}^2) = 67.2 \text{ kips, } R_{n-BB4} = R_{n-BB3} + 67.2 = 172.8 \text{ kips}$$

$$\text{Required additional length in Layer 4} = (240 - 172.8)/4.0 = 17 \text{ feet}$$

$$D_4 = 40 + 17 = 57 \text{ ft, } R_{n-BB5} = R_{n-BB4} + (4.0 \text{ kips/ft}) (17 \text{ ft}) = 172.8 + 68.0 \\ = 240.8 \text{ kips} > 240 \text{ kips needed}$$

The contract pile length includes a 1-foot embedment in the footing [BDM Table 6.2.5] and a 1-foot allowance for cutoff due to driving damage [BDM 6.2.4.2].

$$L = 57 + 1 + 1 = 59 \text{ feet}$$

The length for steel H-piles is specified in 5-foot increments [BDM 6.2.4.2]. Therefore, the contract pile length is rounded to 60 feet.

Uplift may be checked using the previous computations for pile length. Neglecting end bearing (which cannot provide uplift resistance) and including the additional one foot of pile due to round-up, the nominal resistance is

$$240.8 \text{ kips} - 67.2 \text{ kips} + (4.0 \text{ kips/ft}) (1 \text{ ft}) = 177.6 \text{ kips}$$

With a resistance factor of $\phi_{UP} = 0.40$ for non-cohesive soil (Step 5), the factored uplift resistance is:

$$R_{UP} = \phi_{UP} R_{n_UP} = (0.40)(177.6) = 71 \text{ kips} > \text{Factored Uplift Load} = 40 \text{ kips} \text{ OK}$$

Minimum required pile driven length for uplift resistance is:

$$18 \text{ ft} + [40 \text{ kips} - (0.40)(44.0 \text{ kips})] / [(0.40)(2.8 \text{ kips/ft})] = 18 \text{ ft} + 20 \text{ ft} = 38 \text{ ft, say 40ft.}$$

The final design engineer also should check group uplift resistance. For this design guide, it is assumed that the pile spacing is large enough so that group uplift resistance does not control.

The soil below the footing is entirely non-cohesive so there is no need to check the site classification.

Step 8 - Estimate target nominal pile driving resistance, R_{ndr-T}

The complete embedment length below the bottom of footing will contribute to pile driving resistance. Since there was no need to make allowance for pre-boring, downdrag load, or scour, the pile embedment length below bottom of footing will be the same as that considered to estimate R_n .

For driven H-pile with WEAP analysis construction control and no planned retap, the following resistance factor, ϕ , is recommended to estimate the target nominal pile driving resistance in non-cohesive soil [BDM Table 6.2.9-3].

$$\phi_{TAR} = 0.55 \text{ for non-cohesive soil}$$

Therefore, the target nominal pile driving resistance is

$$R_{ndr-T} = \frac{\sum \eta \gamma Q + \gamma_{DD} DD}{\phi_{TAR}} = \frac{132 + 0}{0.55} = 240 \text{ kips} = 120 \text{ tons}$$

Step 9 – Prepare CADD notes for the bridge plans

At this point the final design engineer selects the appropriate CADD notes and adds the specific

pile load values to the notes [BDM 13.8.2].

E718: Pier piles, LRFD contract length and resistance

THE CONTRACT LENGTH OF 60 FEET FOR THE PIER #1 PILES IS BASED ON A NON-COHESIVE SOIL CLASSIFICATION, A TOTAL FACTORED AXIAL LOAD PER PILE (P_U) OF 132 KIPS, AND A GEOTECHNICAL RESISTANCE FACTOR (PHI) OF 0.55 FOR SOIL. PIER PILES ALSO WERE DESIGNED FOR A FACTORED TENSION FORCE OF 50 KIPS.

THE NOMINAL AXIAL BEARING RESISTANCE FOR CONSTRUCTION CONTROL WAS DETERMINED FROM A NON-COHESIVE SOIL CLASSIFICATION AND A GEOTECHNICAL RESISTANCE FACTOR (PHI) OF 0.55. PILES ARE ASSUMED TO BE DRIVEN FROM A START ELEVATION AT THE BOTTOM OF FOOTING.

E719: Pier piles, LRFD driving and construction control

THE REQUIRED NOMINAL AXIAL BEARING RESISTANCE FOR PIER #1 PILES IS 120 TONS AT END OF DRIVE OR RETAP. THE PILE CONTRACT LENGTH SHALL BE DRIVEN AS PER PLAN UNLESS PILES REACH REFUSAL. IN NO CASE SHALL A PILE BE EMBEDDED LESS THAN 40 FEET. CONSTRUCTION CONTROL REQUIRES A WEAP ANALYSIS AND BEARING GRAPH.

Step 10 – Check the design

Within the Bridges and Structures Bureau at the Iowa DOT a final design engineer other than the bridge designer is assigned to give the bridge design an independent check at the time final plans are complete. During the checking process a final design engineer will review the soils package to ensure that all recommendations were followed and also will check structural, geotechnical, and drivability aspects of the design.

Other design organizations may perform checks at various stages of design rather than upon plan completion.

-----**END DESIGN PHASE**-----

-----**BEGIN CONSTRUCTION PHASE**-----

Step 11 – Request and check contractor’s hammer data, and prepare bearing graph for WEAP control

After the bridge contract is let and prior to start of pile driving, the contractor completes Hammer Data sheets for the pile driving hammer that he/she plans to use. The Hammer Data sheets include all pertinent information including the cap (helmet) number and hammer identification information with details, hammer cushion, and pile cushion (where required), as well as pile size, pile length, and estimated pile driving resistance. The Construction and Materials Bureau uses the data received to complete a WEAP analysis for construction control during pile driving.

Results from the WEAP analysis are then used to prepare an LRFD Bearing Graph (without the factor of safety used for allowable stress design). The Bearing Graph includes curves of nominal driving resistance versus blows per foot, and identifies specific driving conditions, where driving stress is a concern.

Step 12 - Observe construction, record driven resistance, and resolve any construction issues

If the recorded pile driving resistance at EOD is less than the target pile nominal driving resistance, then the pile is retapped about 24 hours after EOD. (The retap is a remedial measure that makes use of setup for an individual pile. If the 24-hour retap does not indicate enough driven resistance, an extension will be added the same day rather than wait to retap another day.) For the site in this example, however, retaps are unlikely to be helpful because of the cohesionless soil that usually will not have significant setup.

Track 1, Example 5

Driven H-Pile in Cohesive Soil to Bedrock, and Construction Control Based on Wave Equation with No Planned Retap

(*) On January 1, 2016 per BDM 6.2.4.6 the Bureau recommended the beneficial effects of setup be neglected in the determination of the target nominal pile driving resistance when piles are driven to bedrock. This example was not updated to reflect that recommendation.

General design and construction steps to be modified for project conditions

Design Steps	
Step 1	Develop bridge situation plan (or TS&L, Type, Size, and Location). ⁽¹⁾
Step 2	Develop soils package, including soil borings and foundation recommendations. ⁽¹⁾
Step 3	Determine pile layout, pile loads including downdrag, and other design requirements. ⁽¹⁾ This step includes structural checks.
Step 4	Estimate nominal geotechnical resistance for friction and end bearing.
Step 5	Select resistance factor(s) to estimate pile length based on the soil profile and construction control.
Step 6	Calculate required nominal pile resistance, R_n .
Step 7	Estimate contract pile length, L , considering downdrag, scour, pile uplift, lateral loading, and unbraced length, if applicable.
Step 8	Estimate target nominal pile driving resistance, R_{ndr-T} .
Step 9	Prepare CADD notes for bridge plans.
Step 10	Check the design. ⁽²⁾
Construction Steps	
Step 11	Request and check contractor's hammer data, and prepare bearing graph for WEAP control or other necessary items for alternate methods of construction control.
Step 12	Observe construction, record driven resistance, and resolve any construction issues.

(1) These steps determine the basic information for geotechnical pile design and will vary depending on bridge project and Bureau practice.

(2) Checking will vary depending on bridge project and Bureau practice.

Within the Bridges and Structures Bureau at the Iowa DOT the design steps that determine the basic information necessary for design of a steel H-pile generally follow as indicated in Steps 1-3. The steps involve communication among the preliminary design engineer, soils design engineer, and final design engineer. In other organizations the basic information may be determined differently, but that process generally should not affect the overall design of the pile.

Step 1 - Develop bridge situation plan (or TS&L, Type, Size, and Location)

For a typical bridge the preliminary design engineer plots topographical information, locates the bridge, determines general type of superstructure, location of substructure units, elevations of foundations, hydraulic information (if needed), and other basic information to characterize the bridge. The preliminary design engineer then prepares a TS&L sheet that shows a plan and

longitudinal section of the bridge.

For this example for a state project, the TS&L gives the following information needed for design of abutment piles:

- 312-foot three span, prestressed concrete beam superstructure
- Seven BTC beam cross section
- Zero skew
- Integral abutments
- Pile foundations with 10-foot prebored holes
- Bottom of west abutment footing elevation 5 feet below natural ground elevation

Step 2 - Develop soils package, including soil borings and foundation recommendations

Based on locations of the abutments the soils design engineer orders soil borings, typically at least one per substructure unit. When the engineer receives the boring logs he/she arranges for them to be plotted on a longitudinal section, checks any special geotechnical conditions on the site, and writes a recommendation for foundation type with any applicable special design considerations.

For this example, the recommendations are the following:

- Piles driven to hard shale bedrock at 40 feet below natural ground elevation at west abutment
- Steel H-piles for the integral abutments
- Structural Resistance Level – 2 (which does not require a driving analysis by the Construction and Materials Bureau during design [BDM 6.2.6.1]. SRL-2 in this case allows the designer to consider both friction and end bearing.)
- Normal driving resistance (This will lead to $\phi_c = 0.60$ for the structural check.)
- No special site considerations for stability, settlement, or lateral movement (Therefore a Service I load will not be required for design.)
- Standard construction control based on WEAP analysis with no planned retap

The soil profile is as follows. Stratum 3 is divided into 3A for soil above the elevation 30 feet below natural ground and 3B below 3A. The distinction is for different friction values.

- Stratum 1- Topsoil 4 feet;
- Stratum 2 - Firm glacial clay 14 feet, average N-value = 12;
- Stratum 3A - Very firm glacial clay 12 feet, average N-value = 21;
- Stratum 3B - Very firm glacial clay 10 feet, average N-value 21; and
- Stratum 4 - Hard shale, average SPT N-value = 162.

Step 3 - Determine pile layout, pile loads, and other design requirements. This step includes structural checks.

The final design engineer begins design of the abutment piles with the TS&L and the soils design package. Because the bridge has a prestressed concrete beam superstructure and integral abutments, the engineer selects HP 10×57 piles, following Bridge Design Manual policy [BDM 6.5.1.1.1].

Notation: The same loads are designated in Step 3 with “P” and in Steps 6 and 8 with “Q”.

Based on total Strength I abutment load and Bridge Design Manual policy for pile spacing and number of piles [BDM 6.5.4.1.1], the final design engineer determines the following:

- Strength I factored load for west abutment (not including wing extension) piles = 1330 kips
- Nominal structural resistance per pile at SRL-2 = 365 kips [BDM Table 6.2.6.1-1]
- Nominal maximum structural resistance for an integral abutment pile with 10-foot prebore = 365 kips [BDM Table 6.5.1.1.1-1]
- Minimum number of piles based on structural resistance = $1330/(0.6)(365) = 6.07$, round to 7
- Minimum number of piles based on superstructure cross section: 7 beams, therefore 7 piles [BDM 6.2.4.1]. (The designer also needs to check minimum and maximum pile spacing guidelines in BDM 6.2.4.1.)
- Seven piles with two wing extension piles as shown in the figure below, if geotechnical resistance is sufficient
- Strength I factored load per abutment pile, $P_u = 1330/7 = 190$ kips

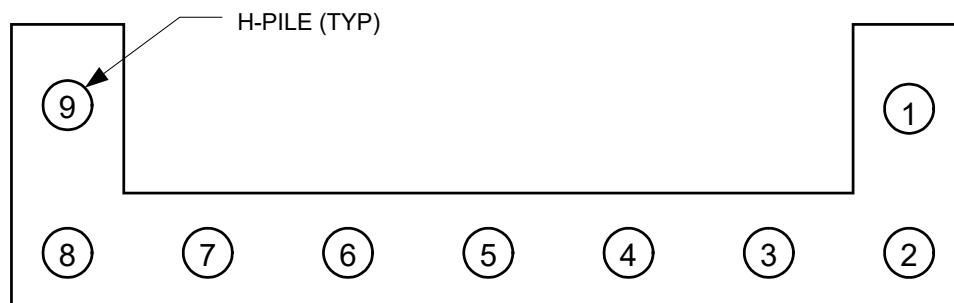

Track 1, Example 5-pile layout at an abutment

Because the bridge characteristics fall within integral abutment policy, the site has no unusual characteristics, the soils design engineer did not require further analysis, the project does not require staged construction, and construction will not be accelerated or delayed, there will be no need for lateral load or special analysis of the abutment piles. They may simply be designed for applied vertical load.

Step 4 - Estimate nominal geotechnical resistance for friction and end bearing

Based on the west abutment soil profile and BDM Tables 6.2.7-1 and 6.2.7-2, the final design engineer estimates the following nominal resistances for friction and end bearing as shown in the table below.

Track 1, Example 5-estimated nominal geotechnical resistance

Soil Stratum	Soil Description	Stratum Thickness (ft)	Average SPT N Value (blows/ft)	Estimated Nominal Resistance for Friction Pile (kips/ft)	Cumulative Nominal Friction Resistance at Bottom of Stratum (kips)	Estimated Nominal Resistance for End Bearing (kips)
1	Topsoil	4 below natural ground	---	---	---	---
2	Firm Glacial Clay	14 total, 3 below prebore	12	2.8	8.4	---
3A	Very Firm Glacial Clay	12	21	2.8	33.6 + 8.4 = 42.0	---
3B	Very Firm Glacial Clay (30 feet below the natural ground elevation)	10	21	4.0	40.0 + 42.0 = 82.0	---
4	Hard Shale	---	162	---	---	(16.8)(12) = 201.6

Step 5 - Select resistance factors to estimate pile length based on the soil profile and construction control

For a driven H-pile with construction control based on a WEAP analysis at EOD and no planned retap, the following resistance factor is recommended to estimate the contract pile length for friction bearing in cohesive soil [BDM Table 6.2.9-1]. Only cohesive soil was present below the west abutment.

$\phi = 0.65$ for cohesive soil, averaged over the full depth of estimated pile penetration

Based on successful past practice with WEAP analysis, the following resistance factor will be used for end bearing on bedrock [BDM 6.2.9].

$\phi = 0.70$ for bedrock

Step 6 – Calculate required nominal pile resistance, R_n

In this example the pile length and geotechnical resistance is determined by the location of bedrock. The designer may simply check the factored resistance, ϕR_n . Using the results from Steps 4 and 5 and adding friction and end bearing factored resistances

$$\phi R_n = (0.65)(82.0) + (0.70)(201.6) = 194.4 \text{ kips}$$

$$[\phi R_n = 194.4 \text{ kips}] > [\gamma Q = 190 \text{ kips}] \text{ OK}$$

In this case with piles driven to bedrock, if the factored geotechnical resistance were insufficient the final design engineer would need to increase the number or size of piles.

Step 7 – Estimate contract pile length, L

With piles driven to bedrock the contract length can be determined from known elevations and an estimate of the length driven into bedrock [BDM Table 6.2.4.2-2]. The recommendation in the table is that piles be driven 4 to 8 feet into hard shale ($50 \leq N \leq 200$). Interpolating first for $N = 162$:

$$L_{br} = 4 + (8-4)(162-50)/(200-50) = 7 \text{ feet}$$

$$L = \text{cutoff} + \text{embedment in abutment} + \text{prebore} + \text{soil layers below prebore} + \text{embedment in bedrock} = 1+2+10+25+7 = 45 \text{ feet}$$

The length for steel H-piles is specified in 5-foot increments [BDM 6.2.4.2]. Therefore, there is no need to round the 45-foot length, but the final design engineer could add 5 feet just to ensure that pile extensions would not be required if the elevation of bedrock is expected to vary over the length of the abutment.

Because the site has only cohesive soil within the length of the pile embedded in soil, the resistance factor determined in Step 5 need not be checked for site classification.

Step 8 - Estimate target nominal pile driving resistance, R_{ndr-T}

The driving resistance will depend on both the friction and end bearing resistances. Because the friction resistance will be achieved before the end bearing resistance, assume that the full friction resistance will be achieved and the remainder of the resistance will be end bearing. The fraction of friction resistance is computed as follows.

$$F_{fr} = (0.65)(82.0)/190 = 0.28$$

The fraction for end bearing then is

$$F_{eb} = 1 - 0.28 = 0.72$$

(*) On January 1, 2016 per BDM 6.2.4.6 the Bureau recommended the beneficial effects of setup be neglected in the determination of the target nominal pile driving resistance when pile is driven to bedrock. This example was not updated to reflect that recommendation.

For driven H-piles with WEAP analysis construction control and no planned retap, the following resistance factors, ϕ , are recommended to estimate the target nominal pile driving resistance for friction in cohesive soils [BDM Table 6.2.9-3].

$\phi_{EOD} = 0.65$ for cohesive soil, averaged over the full depth of estimated pile penetration

$\phi_{SETUP} = 0.20$ for cohesive soil, averaged over the full depth of estimated pile penetration

Determine next the resistance factor for friction in the soil, including setup.

$$N_a = [(3)(12) + (22)(21)]/25 = 20$$

From the graph for seven-day setup, $F_{SETUP} = 1.55$

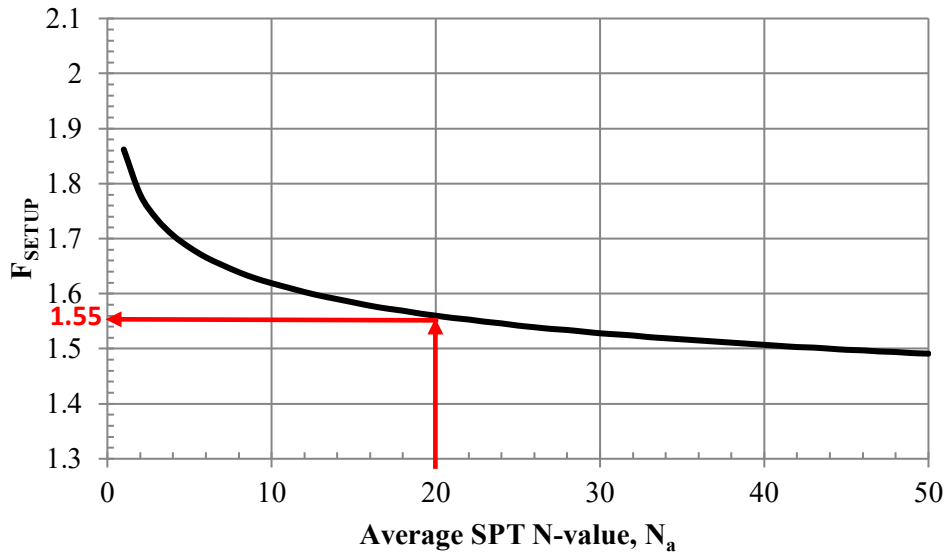

Track 1, Example 5-pile setup factor chart [BDM Figure 6.2.10]

Then determine the target resistance factor for friction in the soil.

$$\phi_{TAR} = \text{Resistance factor for target nominal resistance} \leq 1.00$$

$$= \phi_{EOD} + \phi_{SETUP}(F_{SETUP} - 1)$$

$$= 0.65 + (0.20)(1.55-1) = 0.76$$

Note that $\phi_{TAR} < 1.00$, OK

With the estimated fractions of friction and end bearing, target resistance factor for friction, and the resistance factor of 0.70 for end bearing [BDM 6.2.9], compute the target pile driving

resistance at End of Drive.

$$R_{\text{ndr-T}} = 190 / [(0.28)(0.76) + (0.72)(0.70)] = 265 \text{ kips} = 133 \text{ tons}$$

Step 9 – Prepare CADD notes for bridge plans

At this point the final design engineer selects the appropriate CADD note and adds the specific pile load values to the notes [BDM 13.8.2]. When driving to rock, retaps are ineffective and do not need to be mentioned in the driving and construction control note.

E818: Abutment piles, LRFD contract length and resistance

THE CONTRACT LENGTH OF 45 FEET FOR THE WEST ABUTMENT PILES IS BASED ON A COHESIVE SOIL CLASSIFICATION, A TOTAL FACTORED AXIAL LOAD PER PILE (P_U) OF 190 KIPS, AND A GEOTECHNICAL RESISTANCE FACTOR (ϕ) OF 0.65 FOR SOIL AND 0.70 FOR ROCK END BEARING.

THE NOMINAL AXIAL BEARING RESISTANCE FOR CONSTRUCTION CONTROL WAS DETERMINED FROM A COHESIVE SOIL CLASSIFICATION AND A GEOTECHNICAL RESISTANCE FACTOR (ϕ) OF 0.76 FOR SOIL AND 0.70 FOR ROCK END BEARING. PILES ARE ASSUMED TO BE DRIVEN FROM A START ELEVATION AT THE BOTTOM OF PREBORE.

E819: Abutment piles, driving and construction control

THE REQUIRED NOMINAL AXIAL BEARING RESISTANCE FOR WEST ABUTMENT PILES IS 133 TONS AT END OF DRIVE. THE PILE CONTRACT LENGTH SHALL BE DRIVEN AS PER PLAN UNLESS PILES REACH REFUSAL. CONSTRUCTION CONTROL REQUIRES A WEAP ANALYSIS WITH BEARING GRAPH.

Step 10 – Check the design

Within the Bridges and Structures Bureau at the Iowa DOT a final design engineer other than the bridge designer is assigned to give the bridge design an independent check at the time final plans are complete. During the checking process a final design engineer will review the soils package to ensure that all recommendations were followed and also will check structural, geotechnical, and drivability aspects of the design.

Other design organizations may perform checks at various stages of design rather than upon plan completion.

-----**END DESIGN PHASE**-----

-----**BEGIN CONSTRUCTION PHASE**-----

Step 11 – Request and check contractor’s hammer data, and prepare bearing graph for WEAP control

After the bridge contract is let and prior to start of pile driving, the contractor completes Hammer Data sheets for the pile driving hammer that he/she plans to use. The Hammer Data sheets include all pertinent information including the cap (helmet) number and hammer identification information with details, hammer cushion, and pile cushion (where required), as well as pile size, pile length, and required (or target) nominal axial pile driving resistance. For state projects the Construction and Materials Bureau uses the data received to complete a WEAP analysis for construction control during pile driving. Results from the WEAP analysis are then used to prepare an LRFD Bearing Graph (without the factor of safety used for allowable stress design). The Bearing Graph includes hammer stroke height curves that relate blows per foot to nominal driving resistance, and identifies specific driving conditions, where driving stress is a concern.

Step 12 - Observe construction, record driven resistance, and resolve any construction issues

During pile driving, the construction inspector records the hammer stroke and number of blows to advance the pile an equivalent penetration of 1 foot, and then converts the recorded information with the Bearing Graph to record the driven resistance per pile at EOD.

If the recorded pile driving resistance at EOD is less than the required (or target) nominal axial pile driving resistance, then the pile typically is retapped about 24 hours after EOD. However, when driving to rock as in this case it is unlikely that retaps would be successful because the amount of friction resistance is only about one-quarter of the total resistance (In this case if EOD does not indicate enough driven resistance, an extension will be added.)

Track 1, Example 6

Driven Pipe Pile in Non-Cohesive Soil with Scour, and Construction Control Based on Wave Equation and No Planned Retap

General design and construction steps to be modified for project conditions

Design Steps	
Step 1	Develop bridge situation plan (or TS&L, Type, Size, and Location). ⁽¹⁾
Step 2	Develop soils package, including soil borings and foundation recommendations. ⁽¹⁾
Step 3	Determine pile layout, pile loads including downdrag, and other design requirements. ⁽¹⁾ This step includes structural checks.
Step 4	Estimate nominal geotechnical resistance for friction and end bearing.
Step 5	Select resistance factor(s) to estimate pile length based on the soil profile and construction control.
Step 6	Calculate required nominal pile resistance, R_n .
Step 7	Estimate contract pile length, L , considering downdrag, scour, pile uplift, lateral loading, and unbraced length, if applicable.
Step 8	Estimate target nominal pile driving resistance, R_{ndr-T} .
Step 9	Prepare CADD notes for bridge plans.
Step 10	Check the design. ⁽²⁾
Construction Steps	
Step 11	Request and check contractor's hammer data, and prepare bearing graph for WEAP control or other necessary items for alternate methods of construction control.
Step 12	Observe construction, record driven resistance, and resolve any construction issues.

(1) These steps determine the basic information for geotechnical pile design and will vary depending on bridge project and Bureau practice.

(2) Checking will vary depending on bridge project and Bureau practice.

Use of pipe piles in Iowa is unusual at the present time. However, within the Bridges and Structures Bureau at the Iowa DOT, the design steps that determine the basic information necessary for geotechnical design of a steel pipe pile generally would follow as indicated in Steps 1-3. The steps involve communication among the preliminary design engineer, soils design engineer, and final design engineer. In other organizations the basic information may be determined differently, but that process generally should not affect the overall design of the pile.

Step 1 - Develop bridge situation plan (or TS&L, Type, Size, and Location)

For a typical bridge the preliminary design engineer plots topographical information, locates the bridge, determines general type of superstructure, location of substructure units, elevations of foundations, hydraulic information (if needed), and other basic information to characterize the bridge. The preliminary design engineer then prepares a TS&L sheet that shows a plan and longitudinal section of the bridge.

For this example for a state project, the TS&L gives the following information needed for design

of Pier #1 piles:

- 120-foot, three-span continuous concrete slab superstructure over a small stream
- 40-foot roadway width
- 25-degree skew
- P10L pile bents
- Bottom of pier cap elevation 907 feet
- Streambed elevation 895 feet
- Design scour elevation 888 feet (This indicates 7 feet of scour to be considered at the strength limit state.)
- Check scour elevation 887 feet (This indicates 8 feet of scour to be considered at the extreme event limit state.)
- Relatively constant ground elevation at Pier #1

Step 2 - Develop soils package, including soil borings and foundation recommendations

Based on location of the abutments and pile bents the soils design engineer orders soil borings, typically at least one per substructure unit. When the engineer receives the boring logs he/she arranges for them to be plotted on a longitudinal section, checks any special geotechnical conditions on the site, and writes a recommendation for foundation type with any applicable special design considerations.

Subsurface conditions at Pier #1 have been characterized based on representative test borings. The streambed is underlain by 5 feet of soft to stiff silty clay ($N_a = 4$), 15 feet of fine sand ($N_a = 16$), 40 feet of medium sand ($N_a = 20$), and bouldery gravel and hard shale.

For this example, the recommendations are the following:

- Displacement piles, either concrete-filled steel pipe or prestressed concrete, that tip out in the medium sand layer
- P10L nominal resistance (which does not require a driving analysis by the Construction and Materials Bureau during design)
- No downdrag
- Normal driving resistance
- No special site considerations for stability, settlement, lateral movement, or bearing below the stream [See BDM 6.2.7 with respect to river bridges.] (Therefore a Service I load will not be required for design.)
- Standard construction control based on WEAP analysis with no planned retap

Step 3 - Determine pile layout, pile loads, and other design requirements. This step includes structural checks.

Notation: The same loads are designated in Step 3 with “P” and in Steps 6 and 8 with “Q”.

The final design engineer begins design of the pile bent piles with the TS&L and the soils design package and determines the total factored load at Pier #1.

$$P_u = 1125 \text{ kips}$$

For the bridge configuration and pile bents in this example, which are quite typical, the engineer selects a monolithic cap as preferred by the Bureau [BDM 5.6.1.1.1 and 6.6.4.2.1].

The engineer then checks to ensure that the simplified method for design of pile bents is applicable [BDM 6.6.4.2.1].

- Bridge length = 120 feet < 250 feet OK
- Roadway width = 40 feet < 44 feet OK
- Skew = 25 degrees < 45 degrees OK
- Ground slope along Pier #1 is minimal, certainly < 1:10 OK
- By observation other guidelines for use of the simplified method are met, provided that pile spacing meets the minimum. Pile spacing will be checked below.

Based on the recommendation for displacement piles the engineer selects concrete-filled steel pipe piles. (In Track 1, Example 7 the engineer makes the alternate selection of prestressed concrete piles.)

The unbraced height of the pipe piles from bottom of monolithic cap to design scour is

$$907-888 = 19 \text{ feet}$$

Based on the P10L Standard or BDM Table 6.6.4.2.1.3 the 19-foot height is too large for a 14-inch diameter pile and a 16-inch diameter pile is required.

$$\begin{aligned} 19 \text{ feet} &> 18 \text{ feet maximum for 14-inch pile NG} \\ 19 \text{ feet} &< 22 \text{ feet maximum for 16-inch pile OK} \end{aligned}$$

In this example the 16-inch pile maximum height of 22 feet also exceeds the pile height of 20 feet at check scour. If that were not the case the engineer would need to use judgment and/or analysis to either accept the pile as adequate for design scour and adequate for check scour at the extreme event reduced load, or investigate a larger pipe pile.

Development of the P10L standard included analysis for various typical conditions involving moment at the top of a pile, and the nominal axial resistance given on the standard was limited accordingly. Thus, for typical bridges such as the one in this example, the piles may be designed for axial geotechnical resistance without additional consideration of typical eccentric and lateral loads.

From the P10L Standard or BDM Table 6.6.4.2.1.3 the 16-inch pipe pile has a nominal axial resistance of 137 kips. The BDM Table 6.6.4.2.1.3 footnote indicates that the nominal resistance is to be used with a resistance factor of 0.80, which is from the combined flexure and axial load analysis used in development of the simplified method [AASHTO-LRFD 6.5.4.2]. Thus the number of piles required for Pier #1 is the following:

$$n = P_u / \phi_c P_n = 1125 / (0.80)(137) = 10.26, \text{ use 11 piles}$$

$$P_u \text{ per pile} = 1125 / 11 = 102 \text{ kips}$$

Pile spacing will be about 4.5 feet, which is larger than the minimum, $(2.5)(1.33) = 3.33$ feet OK [BDM 6.6.4.2.1]

End piles will be battered at 1:12 in keeping with Bureau policy [BDM 6.6.1.1.3].

Because the simplified method for design of pile bents is based on a combined moment and axial load analysis with consideration of slenderness near the top of the pile, the axial load without moment at the bottom of the pile does not control. To demonstrate, abbreviated computations for the bottom of the pile using the AASHTO LRFD Specifications for filled tube composite members follow [AASHTO-LRFD 6.9.5.1, 6.9.5.2, and 6.9.4.2].

$KL/r_s = 0$ and $\lambda = 0$ because there is no unbraced length at the bottom of the pile

$$F_e = F_y + C_2 f'_c (A_c / A_s) = 35 + (0.85)(189.67 / 11.4) = 84.50 \text{ ksi}$$

$$P_n = 0.66^{\lambda} F_e A_s = (0.66^0)(84.50)(11.4) = 963 \text{ kips}$$

For good driving conditions and pipe piles, $\phi_c = 0.70$ [AASHTO-LRFD 6.5.4.2].

$\phi_c P_n = (0.70)(963) = 674$ kips $\gg \phi_c P_n = 110$ kips at the top of the pile (and less at the bottom of the pile), so the top controls as stated above. Even with a reduced ϕ_c for hard driving the top of the pile would control the structural design.

Use of pipe piles with the simplified method for pile bents has two additional guidelines, minimum height and minimum soil penetration [BDM Table 6.6.4.2.1.3].

12 feet above streambed without scour > 7 feet minimum OK

Check minimum soil penetration of 27 feet in Step 7.

For structural design in pile bent cases that do not fit the simplifications in BDM 6.6.4.2, see “Commentary Appendix for Technical Documents” available on the Bridges and Structures Bureau Bridge Design Manual web page or at:

<https://iowadot.gov/bridge/policy/06-06-00PierLRFDCATD.pdf>

Step 4 - Estimate nominal geotechnical resistance for friction and end bearing

Based on the subsurface information at the pile bents and BDM Tables 6.2.7-1 and 6.2.7-2, the final design engineer estimates the following nominal resistances for friction and end bearing as shown in the table.

Track 1, Example 6-estimated nominal geotechnical resistance

Soil Stratum	Soil Description	Stratum Thickness (ft)	Average SPT N Value (blows/ft)	Estimated Nominal Resistance for Friction Pile ^{(1),(2)} (kips/ft)	Cumulative Nominal Friction Resistance at Bottom of Layer ⁽²⁾ (kips)	Estimated Nominal Resistance for End Bearing ⁽²⁾ (kips)
1	Soft to Stiff Silty Clay above Scour Elevation	5	4	1.4	7.0	---
2A	Fine Sand above Scour Elevation	2	16	2.6	12.2	---
2	Fine Sand below Scour Elevation	13	16	2.6	46.0	---
3	Medium Sand	40	20	2.9	162.0	---
3	Medium Sand	---	20	---	---	86

(1) These values are the average for 14-inch and 18-inch pipe piles. Because the soil categories and N-values do not fit the geotechnical resistance charts exactly there also is some judgment involved.

(2) This information is used to prepare the calculations in Step 7.

Step 5 - Select a resistance factor to estimate pile length based on the soil profile and construction control

By inspection, more than 70 percent of the embedded pile length will be in non-cohesive soil, and 100 percent of the length below design scour elevation will be in non-cohesive soil. For driven pipe piles with construction control based on a WEAP analysis at EOD and no planned retap, the following resistance factor is recommended to estimate the contract pile length [BDM Table 6.2.9-1].

$\phi = 0.55$ for non-cohesive soil, averaged over the full depth of estimated pile penetration

Step 6 - Calculate required nominal pile resistance, R_n

For non-cohesive soil, there is no significant setup effect. Therefore, the required nominal pile

resistance can be calculated as:

$$R_n = \frac{\sum \eta \gamma Q + \gamma_{DD} DD}{\phi} = \frac{102 + 0}{0.55} = 185.5 \text{ kips/pile}$$

where

$$\sum \eta \gamma Q = \gamma Q = 102 \text{ kips (Step 3)}$$

$$\gamma_{DD} DD = 0 \text{ (no downdrag)}$$

$$\phi = 0.55 \text{ (Step 5)}$$

Step 7 – Estimate contract pile length, L, considering scour and unbraced length

Based on the nominal and cumulative resistance values in Step 4, the nominal geotechnical resistance, R_{n-BB} , per pile is calculated as follows, where D = depth in feet below the streambed.

$$D_0 = 0 \text{ ft, } R_{n-BB0} = 0 \text{ kips}$$

$$D_1 = 5 \text{ ft, } R_{n-BB1} = R_{n-BB0} + 0 = 0 \text{ kips because scour zone provides no support}$$

$$D_2 = 5 + 2 = 7 \text{ ft, } R_{n-BB2} = R_{n-BB1} + 0 = 0 \text{ kips because scour zone provides no support}$$

$$D_3 = 7 + 13 = 20 \text{ ft, } R_{n-BB3} = R_{n-BB2} + (2.6 \text{ kips/ft}) (13 \text{ ft}) = 0 + 33.8 = 33.8 \text{ kips}$$

$$\text{End bearing in Layer 3} = 86 \text{ kips, } R_{n-BB4} = R_{n-BB3} + 86 = 119.8 \text{ kips}$$

$$\text{Required additional length in Layer 3} = (185.5 - 119.8)/2.9 = 22.7, \text{ rounded to 23 feet}$$

$$D_4 = 20 + 23 = 43 \text{ ft, } R_{n-BB5} = R_{n-BB4} + (2.9 \text{ kips/ft}) (23 \text{ ft}) = 119.8 + 66.7 \\ = 186.5 \text{ kips} > 185.5 \text{ kips}$$

The length for steel pipe piles should be specified to the nearest one-foot increment. (Pipe pile lengths should account for cutoff but not be rounded to the nearest 5-foot increment.)

The contract pile length includes 12 feet above stream bed, a 1-foot embedment in the cap, and a 1-foot cutoff for driving damage.

$$L = 43 + 12 + 1 + 1 = 57 \text{ feet}$$

The minimum soil penetration below design scour is 27 feet for the simplified method of pile bent design [Step 3 and BDM Table 6.6.4.2.1.3].

$$L_E = 57 - 1 - 1 - 12 - 7 = 36 \text{ feet} > 27 \text{ feet OK}$$

The plan note should include a minimum embedment of $27 + 7 = 34$ feet below streambed so that there is at least 27 feet at design scour.

Step 8 - Estimate target nominal pile driving resistance, R_{ndr-T}

The complete embedment length below the streambed will contribute to pile driving resistance,

i.e., the soil resistance above scour elevation which was ignored in Step 4 should be considered in pile driving resistance, R_{ndr-T} .

The complete pile embedment length is 43 feet, which is equal to the 57-foot contract pile length minus the pile height above streambed, embedment length in the concrete cap, and cutoff estimate.

The pipe pile will penetrate 38 feet of non-cohesive soil below the streambed.

$$\% \text{ non-cohesive soil} = [38/43] (100) = 88\% > 70\%$$

Therefore, the generalized soil category for pile driving (construction stage) is also "non-cohesive". It should be noted that it is possible for piles for a substructure to have different soil categories during the design stage and during the construction stage.

For driven pipe pile with WEAP analysis construction control and no planned retap, the following resistance factor, ϕ_{TAR} , is recommended to estimate the target nominal pile driving resistance for non-cohesive soil [BDM Table 6.2.9-3].

$\phi_{TAR} = 0.55$ for non-cohesive soil, averaged over the full depth of estimated pile penetration

$$R_{ndr-T} = \frac{\sum \eta \gamma Q + \gamma_{DD} DD}{\phi_{TAR}} + R_{SCOUR}$$

$$= \frac{102 + 0}{0.55} + 12.2$$

$$= 185.5 + 12.2 = 197.7 \text{ kips/pile} = 99 \text{ tons/pile}$$

$$\text{where } R_{SCOUR} = 12.2 \text{ kips (Step 4)}$$

Step 9 – Prepare CADD notes for bridge plans

At this point the final design engineer selects the appropriate CADD notes and adds the specific pile values to the notes.

E718: Pier piles, LRFD contract length and resistance

THE CONTRACT LENGTH OF 57 FEET FOR THE PIER #1 PILES IS BASED ON A NON-COHESIVE SOIL CLASSIFICATION, A TOTAL FACTORED AXIAL LOAD PER PILE (P_U) OF 102 KIPS, AND A GEOTECHNICAL RESISTANCE FACTOR (ϕ) OF 0.55 FOR SOIL.

THE NOMINAL AXIAL BEARING RESISTANCE FOR CONSTRUCTION CONTROL WAS DETERMINED FROM A NON-COHESIVE SOIL CLASSIFICATION AND A GEOTECHNICAL RESISTANCE FACTOR (ϕ) OF

0.55 FOR SOIL. PILES ARE ASSUMED TO BE DRIVEN FROM A START ELEVATION AT THE STREAMBED ELEVATION. DESIGN SCOUR (200-YEAR) WAS ASSUMED TO AFFECT 7 FEET OF EMBEDDED PILE LENGTH AND CAUSE 12 KIPS OF DRIVING RESISTANCE.

E719: Pier piles, LRFD driving and construction control

THE REQUIRED NOMINAL AXIAL BEARING RESISTANCE FOR PIER #1 PILES IS 99 TONS AT END OF DRIVE OR RETAP. THE PILE CONTRACT LENGTH SHALL BE DRIVEN AS PER PLAN UNLESS PILES REACH REFUSAL. IN NO CASE SHALL A PILE BE EMBEDDED LESS THAN 34 FEET BELOW THE STREAMBED. CONSTRUCTION CONTROL REQUIRES A WEAP ANALYSIS AND BEARING GRAPH.

Step 10 – Check the design

Within the Bridges and Structures Bureau at the Iowa DOT a final design engineer other than the bridge designer is assigned to give the bridge design an independent check at the time final plans are complete. During the checking process a final design engineer will review the soils package to ensure that all recommendations were followed and also will check structural, geotechnical, and drivability aspects of the design.

Other design organizations may perform checks at various stages of design rather than upon plan completion.

-----**END DESIGN PHASE**-----

-----**BEGIN CONSTRUCTION PHASE**-----

Step 11 – Prepare bearing graph

After the bridge contract is let and prior to start of pile driving, the contractor completes Hammer Data sheets for the pile driving hammer that he/she plans to use. The Hammer Data sheets include all pertinent information including the cap (helmet) number and hammer identification information with details, hammer cushion, and pile cushion (where required), as well as pile size, pile length, and estimated pile driving resistance. The Construction and Materials Bureau uses the data received to complete a WEAP analysis for construction control during pile driving. Results from the WEAP analysis are then used to prepare an LRFD Bearing Graph (without the factor of safety used for allowable stress design). The Bearing Graph includes curves of nominal driving resistance versus blows per foot, and identifies specific driving conditions, where driving stress is a concern.

Step 12 - Observe construction, record driven resistance, and resolve any construction issues

Usually if the recorded pile driving resistance at EOD is less than the target pile nominal driving resistance the pile is retapped about 24 hours after EOD. (The retap is a remedial measure that

makes use of setup for an individual pile. If the 24-hour retap does not indicate enough driven resistance, an extension will be added the same day rather than wait to retap another day.) In this example it is unlikely that there would be a significant amount of setup because of the non-cohesive soil, and extensions would be required if the driving resistance did not meet the target driving resistance at EOD.

Track 1, Example 7

Driven Prestressed Concrete Pile in Non-Cohesive Soil with Scour, and Construction Control Based on Wave Equation and No Planned Retap

General design and construction steps to be modified for project conditions

Design Steps	
Step 1	Develop bridge situation plan (or TS&L, Type, Size, and Location). ⁽¹⁾
Step 2	Develop soils package, including soil borings and foundation recommendations. ⁽¹⁾
Step 3	Determine pile layout, pile loads including downdrag, and other design requirements. ⁽¹⁾ This step includes structural checks.
Step 4	Estimate nominal geotechnical resistance for friction and end bearing.
Step 5	Select resistance factor(s) to estimate pile length based on the soil profile and construction control.
Step 6	Calculate required nominal pile resistance, R_n .
Step 7	Estimate contract pile length, L , considering downdrag, scour, pile uplift, lateral loading, and unbraced length, if applicable.
Step 8	Estimate target nominal pile driving resistance, R_{ndr-T} .
Step 9	Prepare CADD notes for bridge plans.
Step 10	Check the design. ⁽²⁾
Construction Steps	
Step 11	Request and check contractor's hammer data, and prepare bearing graph for WEAP control or other necessary items for alternate methods of construction control.
Step 12	Observe construction, record driven resistance, and resolve any construction issues.

(3) These steps determine the basic information for geotechnical pile design and will vary depending on bridge project and Bureau practice.

(4) Checking will vary depending on bridge project and Bureau practice.

Use of prestressed concrete piles in Iowa is unusual at the present time. However, within the Bridges and Structures Bureau at the Iowa DOT, the design steps that determine the basic information necessary for geotechnical design of a prestressed concrete pile generally would follow as indicated in Steps 1-3. The steps involve communication among the preliminary design engineer, soils design engineer, and final design engineer. In other organizations the basic information may be determined differently, but that process generally should not affect the overall design of the pile.

Step 1 - Develop bridge situation plan (or TS&L, Type, Size, and Location)

For a typical bridge the preliminary design engineer plots topographical information, locates the bridge, determines general type of superstructure, location of substructure units, elevations of foundations, hydraulic information (if needed), and other basic information to characterize the bridge. The preliminary design engineer then prepares a TS&L sheet that shows a plan and longitudinal section of the bridge.

For this example for a state project, the TS&L gives the following information needed for design of Pier #1 piles:

- 120-foot, three-span continuous concrete slab superstructure over a small stream
- 40-foot roadway width
- 25-degree skew
- P10L pile bents
- Bottom of pier cap elevation 907 feet
- Streambed elevation 895 feet
- Design scour elevation 888 feet (This indicates 7 feet of scour to be considered at the strength limit state.)
- Check scour elevation 887 feet (This indicates 8 feet of scour to be considered at the extreme event limit state.)
- Relatively constant ground elevation at Pier #1

Step 2 - Develop soils package, including soil borings and foundation recommendations

Based on location of the abutments and pile bents the soils design engineer orders soil borings, typically at least one per substructure unit. When the engineer receives the boring logs he/she arranges for them to be plotted on a longitudinal section, checks any special geotechnical conditions on the site, and writes a recommendation for foundation type with any applicable special design considerations.

Subsurface conditions at Pier #1 have been characterized based on representative test borings. The streambed is underlain by 5 feet of soft to stiff silty clay ($N_a = 4$), 15 feet of fine sand ($N_a = 16$), 40 feet of medium sand ($N_a = 20$), and bouldery gravel and hard shale.

For this example, the recommendations are the following:

- Displacement piles, either concrete-filled steel pipe or prestressed concrete, that tip out in the medium sand layer
- P10L nominal resistance (which does not require a driving analysis by the Construction and Materials Bureau during design)
- No downdrag
- Normal driving resistance
- No special site considerations for stability, settlement, lateral movement, or bearing below the stream [See BDM 6.2.7 with respect to river bridges.] (Therefore a Service I load will not be required for design.)
- Standard construction control based on WEAP analysis with no planned retap

Step 3 - Determine pile layout, pile loads, and other design requirements. This step includes structural checks.

Notation: The same loads are designated in Step 3 with “P” and in Steps 6 and 8 with “Q”.

The final design engineer begins design of the pile bent piles with the TS&L and the soils design package and determines the total factored load at Pier #1.

$$P_u = 1125 \text{ kips}$$

For the bridge configuration and pile bents in this example, which are quite typical, the engineer selects a monolithic cap as preferred by the Bureau [BDM 5.6.2.1.1 and 6.6.4.2.1].

The engineer then checks to ensure that the simplified method for design of pile bents is applicable [BDM 6.6.4.2.1].

- Bridge length = 120 feet < 250 feet OK
- Roadway width = 40 feet < 44 feet OK
- Skew = 25 degrees < 45 degrees OK
- Ground slope along Pier #1 is minimal, certainly < 1:10 OK
- By observation other guidelines for use of the simplified method are met, provided that pile spacing meets the minimum. Pile spacing will be checked below.

Based on the recommendation for displacement piles the engineer selects prestressed concrete piles. (In Track 1, Example 6 the engineer makes the alternate selection of concrete-filled steel pipe piles.)

The unbraced height of the prestressed concrete piles from bottom of monolithic cap to design scour is

$$907 - 888 = 19 \text{ feet}$$

Based on the P10L Standard or BDM Table 6.6.4.2.1.3 the 19-foot height is too large for a 14-inch square pile and a 16-inch square pile is required.

$$19 \text{ feet} > 18 \text{ feet maximum for 14-inch pile NG}$$

$$19 \text{ feet} < 22 \text{ feet maximum for 16-inch pile OK}$$

In this example the maximum 16-inch pile height of 22 feet also exceeds the pile height of 20 feet at check scour. If that were not the case the engineer would need to use judgment and/or analysis to either accept the pile as adequate for design scour and adequate for check scour at the extreme event reduced load, or investigate a larger pipe pile.

Development of the P10L standard included analysis for various typical conditions involving moment at the top of a pile, and the nominal axial resistance given on the standard was limited accordingly. Thus, for typical bridges such as the one in this example, the piles may be designed

for axial geotechnical resistance without additional consideration of eccentric and lateral loads.

From the P10L Standard or BDM Table 6.6.4.2.1.2 the 16-inch prestressed concrete pile has a nominal axial resistance of 146 kips. The BDM Table 6.6.4.2.1.2 footnote indicates that the nominal resistance is to be used with a resistance factor of 0.75, which is from the combined flexure and axial load analysis used in development of the simplified method [AASHTO-LRFD 5.5.4.2]. Thus the number of piles require for Pier #1 is the following:

$$n = P_u / \phi_c P_n = 1125 / (0.75)(146) = 10.27, \text{ use 11 piles}$$

$$P_u \text{ per pile} = 1125 / 11 = 102 \text{ kips}$$

Pile spacing will be about 4.5 feet, which is larger than the minimum, $(2.5)(1.33) = 3.33$ feet OK [BDM 6.6.4.2.1]

End piles will be battered at 1:12 in keeping with Bureau policy [BDM 6.6.1.1.3].

Because the simplified method for design of pile bents is based on a combined moment and axial load analysis at the top of the pile, the axial load without moment at the bottom of the pile does not control.

Use of prestressed concrete piles with the simplified method for pile bents has two additional guidelines, minimum height and minimum soil penetration [BDM Table 6.6.4.2.1.2].

12 feet above streambed without scour > 7 feet minimum OK

Check minimum soil penetration of 27 feet in Step 7.

For structural design in pile bent cases that do not fit the simplifications in BDM 6.6.4.2, see “Commentary Appendix for Technical Documents” available on the Bridges and Structures Bureau Bridge Design Manual web page or at:

<https://iowadot.gov/bridge/policy/06-06-00PierLRFDCATD.pdf>

Step 4 - Estimate nominal geotechnical resistance for friction and end bearing

Based on the subsurface information at the pile bents and BDM Tables 6.2.7-1 and 6.2.7-2, the final design engineer estimates the following nominal resistances for friction and end bearing as shown in the table.

Track 1, Example 7-estimated nominal geotechnical resistance

Soil Stratum	Soil Description	Stratum Thickness (ft)	Average SPT N Value (blows/ft)	Estimated Nominal Resistance for Friction Pile ^{(1), (2)} (kips/ft)	Cumulative Nominal Friction Resistance at Bottom of Layer ⁽²⁾ (kips)	Estimated Nominal Resistance for End Bearing ⁽²⁾ (kips)
1	Soft to Stiff Silty Clay above Scour Elevation	5	4	1.4	7.0	---
2A	Fine Sand above Scour Elevation	2	16	3.2	13.4	---
2	Fine Sand below Scour Elevation	13	16	3.2	55.0	---
3	Medium Sand	40	20	3.6	199.0	---
3	Medium Sand	---	20	---	---	108

(1) Because the soil categories and N-values do not fit the geotechnical resistance charts exactly there is some judgment involved in selecting and interpolating for these values.

(2) This information is used to prepare the calculations in Step 7.

Step 5 - Select a resistance factor to estimate pile length based on the soil profile and construction control

By inspection, more than 70 percent of the embedded pile length will be in non-cohesive soil, and 100 percent of the length below design scour elevation will be in non-cohesive soil. For driven prestressed concrete piles with construction control based on a WEAP analysis at EOD and no planned retap, the following resistance factor is recommended to estimate the contract pile length [BDM Table 6.2.9-1].

$\phi = 0.55$ for non-cohesive soil, averaged over the full depth of estimated pile penetration

Step 6 - Calculate required nominal pile resistance, R_n

For non-cohesive soil, there is no significant setup effect. Therefore, the required nominal pile resistance can be calculated as:

$$R_n = \frac{\sum \eta \gamma Q + \gamma_{DD} DD}{\phi} = \frac{102 + 0}{0.55} = 185.5 \text{ kips/pile}$$

where

$$\sum \eta \gamma Q = \gamma Q = 102 \text{ kips (Step 3)}$$

$$\gamma_{DD} DD = 0 \text{ (no downdrag)}$$

$$\phi = 0.55 \text{ (Step 5)}$$

Step 7 – Estimate contract pile length, L, considering scour and unbraced length

Based on the nominal and cumulative resistance values in Step 4, the nominal geotechnical resistance, R_{n-BB} , per pile is calculated as follows, where D = depth in feet below the streambed.

$$D_0 = 0 \text{ ft, } R_{n-BB0} = 0 \text{ kips}$$

$$D_1 = 5 \text{ ft, } R_{n-BB1} = R_{n-BB0} + 0 = 0 \text{ kips because scour zone provides no support}$$

$$D_2 = 5 + 2 = 7 \text{ ft, } R_{n-BB2} = R_{n-BB1} + 0 = 0 \text{ kips because scour zone provides no support}$$

$$D_3 = 7 + 13 = 20 \text{ ft, } R_{n-BB3} = R_{n-BB2} + (3.2 \text{ kips/ft}) (13 \text{ ft}) = 0 + 41.6 = 41.6 \text{ kips}$$

$$\text{End bearing in Layer 3} = 108 \text{ kips, } R_{n-BB4} = R_{n-BB3} + 108 = 149.6 \text{ kips}$$

$$\text{Required additional length in Layer 3} = (185.5 - 149.6)/3.6 = 10.0 \text{ feet}$$

$$D_4 = 20 + 10 = 30 \text{ ft, } R_{n-BB5} = R_{n-BB4} + (3.6 \text{ kips/ft}) (10 \text{ ft}) = 149.6 + 36.0 \\ = 185.6 \text{ kips} > 185.5 \text{ kips}$$

The length for prestressed concrete piles is specified in one-foot increments [BDM 6.2.4.2], but extensions should be specified to the nearest 5 feet. In this example the pile is short enough that no initial extension is required, and the 43-foot length is the contract length. (Prestressed concrete pile lengths need not account for cutoff.)

The contract pile length includes 12 feet above stream bed and a 1-foot embedment in the cap.

$$L = 30 + 12 + 1 = 43 \text{ feet}$$

The minimum soil penetration below design scour is 27 feet for the simplified method of pile bent design [Step 3 and BDM Table 6.6.4.2.1.2].

$$L_E = 43 - 1 - 12 - 7 = 23 \text{ feet} < 27 \text{ feet NG, therefore increase contract length by 4 feet to 47 feet.}$$

The plan note should include a minimum embedment of $27 + 7 = 34$ feet below streambed so that there is at least 27 feet embedment at design scour. In this example the full contract length must be driven.

Step 8 - Estimate target nominal pile driving resistance, R_{ndr-T}

The complete embedment length below the streambed will contribute to pile driving resistance, i.e., the soil resistance above scour elevation which was ignored in Step 4 should be considered in pile driving resistance, R_{ndr-T} .

The complete pile embedment length is 34 feet, which is equal to the 47-foot contract pile length

minus the pile height above streambed and embedment length in the concrete cap.

The pile will penetrate 27 feet of non-cohesive soil below the streambed.

$$\% \text{ non-cohesive soil} = [27/34] (100) = 79\% > 70\%$$

Therefore, the generalized soil category for pile driving (construction stage) is also "non-cohesive". It should be noted that it is possible for piles for a substructure to have different soil categories during the design stage and during the construction stage.

For driven prestressed concrete pile with WEAP analysis construction control and no planned retap, the following resistance factor, ϕ_{TAR} , is recommended to estimate the target nominal pile driving resistance for non-cohesive soil [BDM Table 6.2.9-3].

$\phi_{TAR} = 0.55$ for non-cohesive soil, averaged over the full depth of estimated pile penetration

$$R_{ndr-T} = \frac{\sum \eta \gamma Q + \gamma_{DD} DD}{\phi_{TAR}} + R_{SCOUR}$$

$$= \frac{102 + 0}{0.55} + 13.4$$

$$= 185.5 + 13.4 = 198.9 \text{ kips/pile} = 100 \text{ tons/pile}$$

$$\text{where } R_{SCOUR} = 13.4 \text{ kips (Step 4)}$$

Step 9 – Prepare CADD notes for bridge plans

At this point the final design engineer selects the appropriate CADD notes and adds the specific pile values to the notes.

E718: Pier piles, LRFD contract length and resistance

THE CONTRACT LENGTH OF 47 FEET FOR THE PIER #1 PILES IS BASED ON A NON-COHESIVE SOIL CLASSIFICATION, A TOTAL FACTORED AXIAL LOAD PER PILE (P_U) OF 102 KIPS, AND A GEOTECHNICAL RESISTANCE FACTOR (ϕ) OF 0.55 FOR SOIL.

THE NOMINAL AXIAL BEARING RESISTANCE FOR CONSTRUCTION CONTROL WAS DETERMINED FROM A NON-COHESIVE SOIL CLASSIFICATION AND A GEOTECHNICAL RESISTANCE FACTOR (ϕ) OF 0.55 FOR SOIL. PILES ARE ASSUMED TO BE DRIVEN FROM A START ELEVATION AT THE STREAMBED ELEVATION. DESIGN SCOUR (200-YEAR) WAS ASSUMED TO AFFECT 7 FEET OF EMBEDDED PILE LENGTH AND CAUSE 13 KIPS OF DRIVING RESISTANCE.

E719: Pier piles, LRFD driving and construction control

THE REQUIRED NOMINAL AXIAL BEARING RESISTANCE FOR PIER #1 PILES IS 100 TONS AT END OF DRIVE OR RETAP. THE PILE CONTRACT LENGTH SHALL BE DRIVEN AS PER PLAN UNLESS PILES REACH REFUSAL. IN NO CASE SHALL A PILE BE EMBEDDED LESS THAN 34 FEET BELOW THE STREAMBED. CONSTRUCTION CONTROL REQUIRES A WEAP ANALYSIS AND BEARING GRAPH.

Step 10 – Check the design

Within the Bridges and Structures Bureau at the Iowa DOT a final design engineer other than the bridge designer is assigned to give the bridge design an independent check at the time final plans are complete. During the checking process a final design engineer will review the soils package to ensure that all recommendations were followed and also will check structural, geotechnical, and drivability aspects of the design.

Other design organizations may perform checks at various stages of design rather than upon plan completion.

-----**END DESIGN PHASE**-----

-----**BEGIN CONSTRUCTION PHASE**-----

Step 11 – Prepare bearing graph

After the bridge contract is let and prior to start of pile driving, the contractor completes Hammer Data sheets for the pile driving hammer that he/she plans to use. The Hammer Data sheets include all pertinent information including the cap (helmet) number and hammer identification information with details, hammer cushion, and pile cushion (where required), as well as pile size, pile length, and estimated pile driving resistance. The Construction and Materials Bureau uses the data received to complete a WEAP analysis for construction control during pile driving. Results from the WEAP analysis are then used to prepare an LRFD Bearing Graph (without the factor of safety used for allowable stress design). The Bearing Graph includes curves of nominal driving resistance versus blows per foot, and identifies specific driving conditions, where driving stress is a concern.

Step 12 - Observe construction, record driven resistance, and resolve any construction issues

Usually if the recorded pile driving resistance at EOD is less than the target pile nominal driving resistance the pile is retapped about 24 hours after EOD. (The retap is a remedial measure that makes use of setup for an individual pile. If the 24-hour retap does not indicate enough driven resistance, an extension will be added the same day rather than wait to retap another day.) In this example it is unlikely that there would be a significant amount of setup because of the non-cohesive soil, and extensions would be required if the driving resistance did not meet the target driving resistance at EOD.

Track 2, Example 1

Driven H-Pile in Cohesive Soil with Construction Control Based on Iowa DOT ENR Formula and No Planned Retap

General design and construction steps to be modified for project conditions

Design Steps	
Step 1	Develop bridge situation plan (or TS&L, Type, Size, and Location). ⁽¹⁾
Step 2	Develop soils package, including soil borings and foundation recommendations. ⁽¹⁾
Step 3	Determine pile layout, pile loads including downdrag, and other design requirements. ⁽¹⁾ This step includes structural checks.
Step 4	Estimate nominal geotechnical resistance for friction and end bearing.
Step 5	Select resistance factor(s) to estimate pile length based on the soil profile and construction control.
Step 6	Calculate required nominal pile resistance, R_n .
Step 7	Estimate contract pile length, L, considering downdrag, scour, pile uplift, lateral loading, and unbraced length, if applicable.
Step 8	Estimate target nominal pile driving resistance, R_{ndr-T} .
Step 9	Prepare CADD notes for bridge plans.
Step 10	Check the design. ⁽²⁾
Construction Steps	
Step 11	Request and check contractor's hammer data, and prepare bearing graph for WEAP control or other necessary items for alternate methods of construction control
Step 12	Observe construction, record driven resistance, and resolve any construction issues.

(1) These steps determine the basic information for geotechnical pile design and will vary depending on bridge project and Bureau practice.

(2) Checking will vary depending on bridge project and Bureau practice.

Within the Bridges and Structures Bureau at the Iowa DOT the design steps that determine the basic information necessary for design of a steel H-pile generally follow as indicated in Track 1, Example 1. Because Track 2 will not be used by the Iowa DOT this example simply gives the basic information for the design. That information would be determined in various ways depending on the bridge owner (county or city) and any involved engineering consultants. The process generally should not affect the overall design of the pile. Because counties and cities typically follow state standards, this example contains references to the Bridge Design Manual [BDM].

Step 1 - Develop bridge situation plan (or TS&L, Type, Size, and Location)

An engineer involved in the bridge project plots topographical information, locates the bridge, determines general type of superstructure, location of substructure units, elevations of foundations, hydraulic information (if needed), and other basic information to characterize the bridge. The engineer then prepares a TS&L sheet that shows a plan and longitudinal section of the bridge.

For this example for a non-state project, the TS&L gives the following information needed for design of abutment piles:

- 120-foot single span, prestressed concrete beam superstructure
- Zero skew
- Integral abutments (because these are standard practice for non-skewed bridges less than 575 feet in length with end or single spans not exceeding the length of standard prestressed concrete beams) [BDM 6.5.1.1.1]
- Pile foundations, no prebored holes (because the bridge length is less than 130 feet) [BDM 6.5.1.1.1]
- Bottom of west abutment footing elevation 433 feet

Step 2 - Develop soils information, including soil borings and foundation recommendations

Based on location of the abutments an engineer involved in the bridge project orders soil borings, typically at least one per substructure unit. When the engineer receives the boring logs he/she arranges for them to be plotted on a longitudinal section, checks any special geotechnical conditions on the site, and develops recommendations for foundation type with any applicable special design considerations.

For this example, the recommendations are the following:

- Friction piles that tip out in the firm glacial clay layer
- Steel H-piles for the integral abutments
- Structural Resistance Level – 1 (which does not require a WEAP driving analysis during design for state projects [BDM 6.2.6.1]. It is likely then that construction control by formula, as in this example, would be adequate.)
- Normal driving resistance (This will lead to $\phi_c = 0.6$ for the structural check.)
- No special site considerations for stability, settlement, or lateral movement (Therefore the Service I load will not be required for design.)
- Construction control based on the Iowa DOT ENR Formula (modified to remove factor of safety) with no planned retap

The soil profile shown below includes the following soil boring at the west abutment. Generally below the bottom of footing elevation there are three layers: 6 feet of soft silty clay, 9 feet of silty sand, and firm glacial clay to the bottom of the boring at 95 feet. Layer 3 is subdivided at a depth of 30 feet because nominal friction resistance step-increases at that elevation [BDM Table

6.2.7-2]. No groundwater was encountered in the boring.

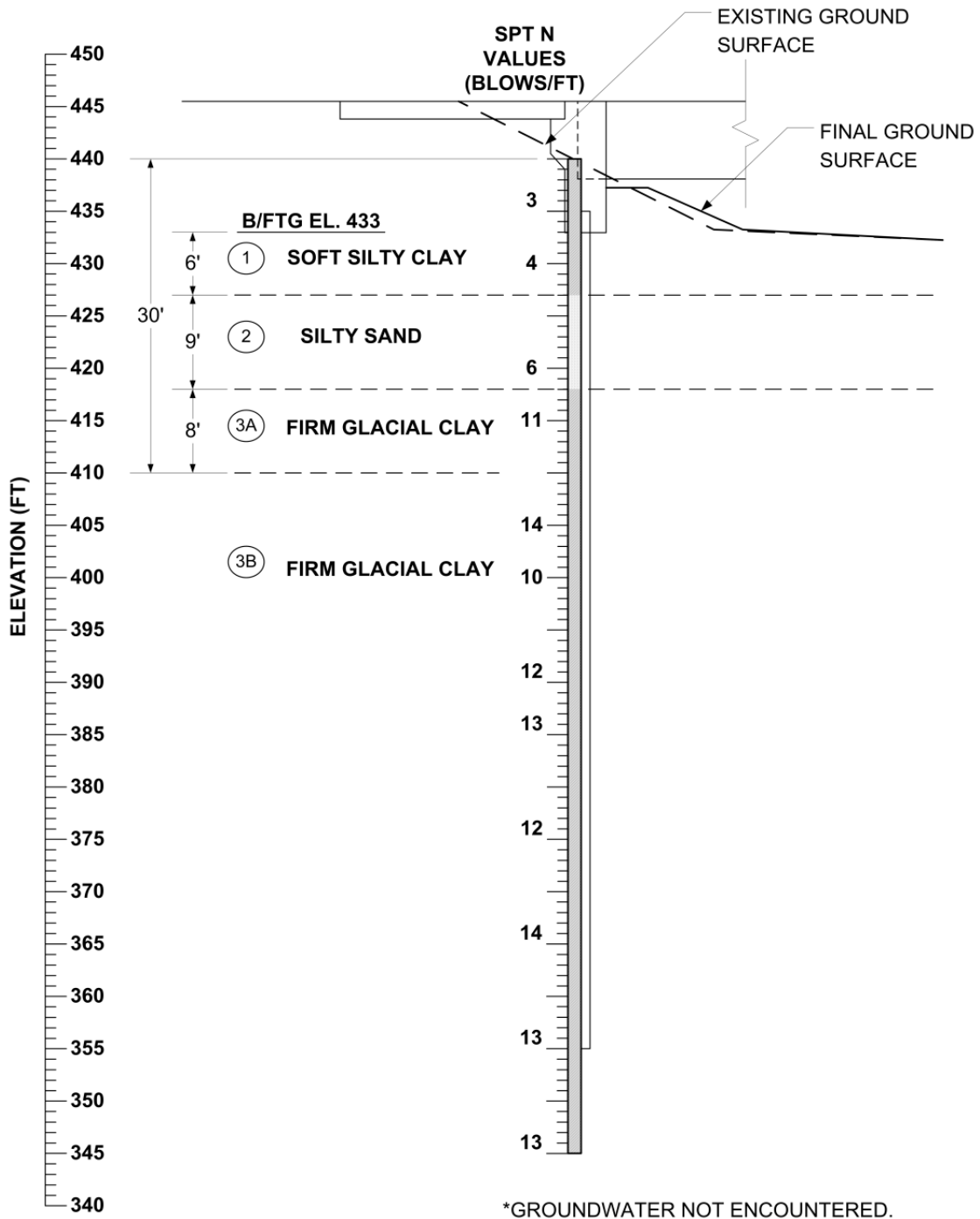

Track 2, Example 1-soil profile at west abutment

Step 3 - Determine pile layout, pile loads, and other design requirements. This step includes structural checks.

An engineer involved in the bridge project begins design of the abutment piles with the TS&L, boring logs, and foundation recommendations. Because the bridge has a prestressed concrete beam superstructure and integral abutments the engineer selects HP 10×57 piles, following Bridge Design Manual policy [BDM 6.5.1.1.1].

There is no uplift, downdrag, or scour. Because the bridge characteristics fall within integral abutment policy, the site has no unusual characteristics, the soils design engineer did not require further analysis, and construction will not be accelerated or delayed, there will be no need for lateral load or special analysis of the abutment piles. They may simply be designed for vertical load.

Notation: The same loads are designated in Step 3 with “P” and in Steps 6 and 8 with “Q”.

For the west abutment

$$\Sigma \eta \gamma P + \gamma_{DD} DD = 895 + 0 = 895 \text{ kips} = P_u$$

The soils package indicates normal driving resistance, therefore

$$\phi_c = 0.60$$

The soils engineer recommends SRL-1 for which

$$P_n = 243 \text{ kips [BDM Table 6.2.6.1-1]}$$

Considering the TS&L and other project factors the final design engineer selects BTC beams [BDM Table 5.4.1.1.1]. For integral abutments with BTC beams and prebored holes for the piles, the maximum $P_n = 365$ kips [BDM Table 6.5.1.1.1-1]. With the short span, the prebored holes are not necessary and, for this project, 365 kips would be the limit per integral abutment pile. The SRL-1 value controls, however.

Required number of piles

$$n = P_u / \phi P_n = 895 / (0.60)(243) = 6.14, \text{ round to 7 piles}$$

Each pile then must carry

$$P_u = 895 / 7 = 128 \text{ kips}$$

The pile layout will be seven piles under the abutment plus one pile for each wing extension as shown below. (For the number of beams the designer checks the minimum number of piles, and for the abutment dimensions the designer checks the pile spacing guidelines [BDM 6.2.4.1]. Those checks are not shown here.) In this case the wing extension piles are added for abutment stability and are moderately loaded so they need not be checked for structural resistance.

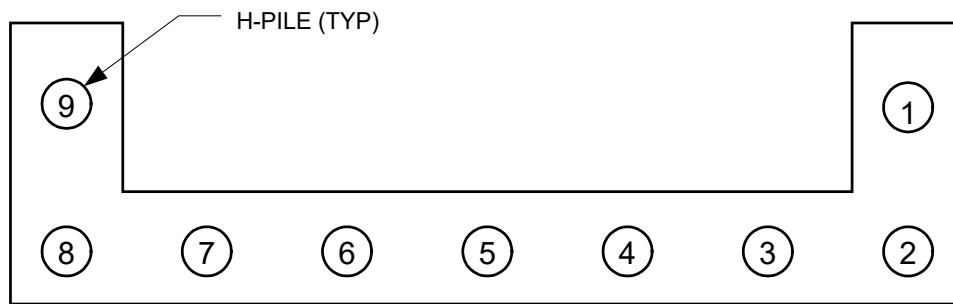

Track 2, Example 1-pile layout at west abutment

Step 4 - Estimate nominal geotechnical resistance for friction

Based on the west abutment soil boring and BDM Table 6.2.7-2, the engineer estimates the following unit nominal resistances for friction bearing.

Track 2, Example 1-estimated nominal unit geotechnical resistance

Soil Stratum	Soil Description		Stratum Thickness (ft)	Average SPT N Value (blows/ft)	Estimated Unit Nominal Resistance for Friction Pile (kips/ft)
1	Soft Silty Clay		6	4	0.8
2	Silty Sand		9	6	1.2
3A	Firm Glacial Clay	within 30 feet of natural ground elevation	8	11	2.8
3B		more than 30 feet below natural ground elevation	65	12	3.2

The firm glacial clay stratum has been divided into two parts, to delineate the embedded pile length that is within 30 feet of the natural ground surface as noted in the BDM geotechnical resistance chart [BDM Table 6.2.7-2]. Application of the chart to estimate the nominal resistance values is illustrated on the next page. Note that the SPT N values are too small for use of end bearing in Layer 3B [BDM Table 6.2.7-1].

Track 2, Example 2-BDM geotechnical resistance chart [BDM Table 6.2.7-2]

SOIL DESCRIPTION	BLOW COUNT		ESTIMATED NOMINAL RESISTANCE VALUES FOR FRICTION PILE IN KIPS PER FOOT											
	N-VALUE		WOOD PILE	STEEL "H"			PRESTRESSED			STEEL PIPE				
	MEAN	RANGE		10	12	14	12	14	16	10	12	14	18	
Alluvium or Loess														
Very soft silty clay	1	0 - 1	0.8	0.4	0.8	0.8	0.8	0.8	0.8	0.8	0.4	0.4	0.4	0.8
Soft silty clay	3	2 - 4	1.2	0.8	1.2	1.2	0.8	0.8	0.8	0.8	0.8	0.8	0.8	1.2
Stiff silty clay	6	4 - 8	1.6	1.2	1.6	2.0	1.2	1.6	2.0	1.2	1.2	1.6	2.0	
Firm silty clay	11	7 - 15	2.4	2.0	2.4	2.8	2.4	2.8	3.2	1.6	2.0	2.4	2.8	
Stiff silt	6	3 - 7	1.6	1.2	1.6	1.6	1.6	1.6	1.6	1.2	1.2	1.6	1.6	
Stiff sandy silt	6	4 - 8	1.6	1.2	1.6	1.6	1.6	1.6	1.6	1.2	1.2	1.6	1.6	
Stiff sandy clay	6	4 - 8	1.6	1.2	1.6	2.0	2.0	2.0	2.4	1.2	1.6	1.6	2.0	
Silty sand	8	3 - 13	1.2	1.2	1.2	1.6	1.6	1.6	1.6	0.8	0.8	1.2	1.6	
Clayey sand	13	6 - 20	2.0	1.6	2.0	2.8	2.4	2.4	2.8	1.6	2.0	2.4	2.8	
Fine sand	15	8 - 22	2.4	2.0	2.4	2.8	2.4	2.8	3.2	1.6	2.0	2.4	2.8	
Coarse sand	20	12 - 28	3.2	2.8	3.2	3.6	3.2	3.6	4.0	2.0	2.4	2.8	3.6	
Gravelly sand	21	11 - 31	3.2	2.8	3.2	3.6	3.6	3.6	4.0	2.0	2.4	2.8	3.6	
Granular material	> 40	---	(2)	4.0	4.8	5.6	(2)	(2)	(2)	(2)	(2)	(2)	(2)	(2)
Glacial Clay														
Firm silty glacial clay	11	7 - 15	2.8	2.4	2.8	3.2	2.8	3.2	3.6	2.0	2.4	2.4	3.2	
Firm clay (gumbotil)	12	9 - 15	2.8	2.4	2.8	3.2	2.8	3.2	3.6	2.0	2.4	2.4	3.2	
Firm glacial clay ⁽¹⁾	11	7 - 15	2.4	2.8	3.2	3.6	3.2	3.6	4.0	2.0	2.4	2.8	3.6	
			[3.2]	[3.2]	[4.0]	[4.4]	[4.0]	[4.4]	[4.8]	[2.4]	[2.8]	[3.2]	[4.4]	
Firm sandy glacial clay ⁽¹⁾	13	9 - 15	2.4	2.8	3.2	3.6	3.2	3.6	4.0	2.0	2.4	2.8	3.6	
			[3.2]	[3.2]	[4.0]	[4.4]	[4.0]	[4.4]	[4.8]	[2.4]	[2.8]	[3.2]	[4.4]	
Firm - very firm glacial clay ⁽¹⁾	14	11 - 17	2.8	2.8	3.2	3.6	4.0	4.4	4.8	2.4	2.8	3.2	4.0	
			[3.6]	[4.0]	[4.8]	[5.6]	[4.8]	[5.2]	[5.6]	[3.2]	[3.6]	[4.0]	[5.2]	
Very firm glacial clay ⁽¹⁾	24	17 - 30	2.8	2.8	3.2	3.6	3.2 ⁽³⁾	3.6 ⁽³⁾	4.4 ⁽³⁾	2.4	2.8	3.2	4.0	
			[3.6]	[4.0]	[4.8]	[5.6]	[4.8]	[5.6]	[6.4]	[3.2]	[3.6]	[4.0]	[5.2]	
Very firm sandy glacial clay ⁽¹⁾	25	15 - 30	3.2	2.8	3.2	3.6	3.2 ⁽³⁾	3.6 ⁽³⁾	4.4 ⁽³⁾	2.4	2.8	3.2	4.0	
			[4.0]	[4.0]	[4.8]	[5.6]	[4.8]	[5.6]	[6.4]	[3.2]	[3.6]	[4.0]	[5.2]	
Cohesive or glacial material ⁽¹⁾	> 35	---	(2)	2.8	3.2	3.6	(2)	(2)	(2)	2.0 ⁽⁴⁾	2.4 ⁽⁴⁾	2.8 ⁽⁴⁾	3.6 ⁽⁴⁾	
			[4.0]	[4.8]	[5.6]					[3.2]	[4.0]	[4.4]	[5.6]	

Table notes:

- (1) For double entries the upper value is for an embedded pile within 30 feet of the natural ground elevation, and the lower value [] is for pile depths more than 30 feet below the natural ground elevation.
- (2) Do not consider use of this pile type for this soil condition, wood with N > 25, prestressed concrete with N > 35, or steel pipe with N > 40.
- (3) Prestressed concrete piles have proven to be difficult to drive in these soils. Prestressed piles should not be driven in glacial clay with consistent N > 30 to 35.
- (4) Steel pipe piles should not be driven in soils with consistent N > 40.

Step 5 - Select resistance factor to estimate pile length based on the soil profile and construction control

In this step the engineer first characterizes the site as cohesive, mixed, or non-cohesive based on soil classification in the table below and the soil profile.

Track 2, Example 1-soil classification table [BDM Table 6.2.8]

Generalized Soil Category	Soil Classification Method			
	AASHTO	USDA Textural	BDM 6.2.7 Geotechnical Resistance Charts	
Cohesive	A-4, A-5, A-6 and A-7	Clay Silty clay Silty clay loam Silt Clay loam Silt loam Loam Sandy clay	Loess	Very soft silty clay
				Soft silty clay
				Stiff silty clay
				Firm silty clay
				Stiff silt
			Glacial Clay	Stiff sandy clay
				Firm silty glacial clay
				Firm clay (gumbotil)
				Firm glacial clay
				Firm sandy glacial clay
				Firm-very firm glacial clay
				Very firm glacial clay
				Very firm sandy glacial clay
				Cohesive or glacial material
Non-Cohesive	A-1, A-2 and A-3	Sandy clay loam Sandy loam Loamy sand Sand	Alluvium Or Loess	Stiff sandy silt
				Silty sand
				Clayey sand
				Fine sand
				Coarse sand
				Gravelly sand
				Granular material (N>40)

Only the 9-foot Layer 2 of silty sand is classified as non-cohesive. The remainder of the profile is classified as cohesive, and most likely will represent more than 70% of the pile embedment length. Thus the soil is expected to fit the cohesive classification, and the resistance factor is selected from the choices below as 0.60 [BDM Table 6.2.9-1].

- $\phi = 0.60$ for cohesive soil, averaged over the full depth of estimated pile penetration
- $\phi = 0.60$ for mixed soil, averaged over the full depth of estimated pile penetration
- $\phi = 0.50$ for non-cohesive soil, averaged over the full depth of estimated pile penetration

Step 6 - Calculate required nominal pile resistance, R_n

The required nominal pile resistance is:

$$R_n = \frac{\sum \eta \gamma Q + \gamma_{DD} DD}{\phi} = \frac{128 + 0}{0.60} = 213 \text{ kips/pile}$$

where,

$$\sum \eta \gamma Q = \gamma Q = 128 \text{ kips (Step 3)}$$

$$\gamma_{DD} DD = 0 \text{ (no downdrag)}$$

$$\phi = 0.60 \text{ (Step 5)}$$

Step 7 – Estimate contract pile length, L

Based on the nominal resistance values in Step 4, the cumulative nominal geotechnical resistance, R_{n-BB} , per pile is calculated as follows, where D = depth in feet below the bottom of footing.

$$D_0 = 0 \text{ ft, } R_{n-BB0} = 0$$

$$D_1 = 6 \text{ ft, } R_{n-BB1} = R_{n-BB0} + (0.8 \text{ kips/ft}) (6 \text{ ft}) = 4.8 \text{ kips}$$

$$D_2 = 6 + 9 = 15 \text{ ft, } R_{n-BB2} = R_{n-BB1} + (1.2 \text{ kips/ft}) (9 \text{ ft}) = 4.8 + 10.8 = 15.6 \text{ kips}$$

$$D_3 = 15 + 8 = 23 \text{ ft, } R_{n-BB3} = R_{n-BB2} + (2.8 \text{ kips/ft}) (8 \text{ ft}) = 15.6 + 22.4 = 38.0 \text{ kips}$$

$$D_4 = 23 + 65 = 88 \text{ ft, } R_{n-BB4} = R_{n-BB3} + (3.2 \text{ kips/ft}) (65 \text{ ft}) = 38.0 + 208.0 = 246.0 \text{ kips}$$

A graphic presentation of the estimated nominal geotechnical resistance per pile versus depth is presented below.

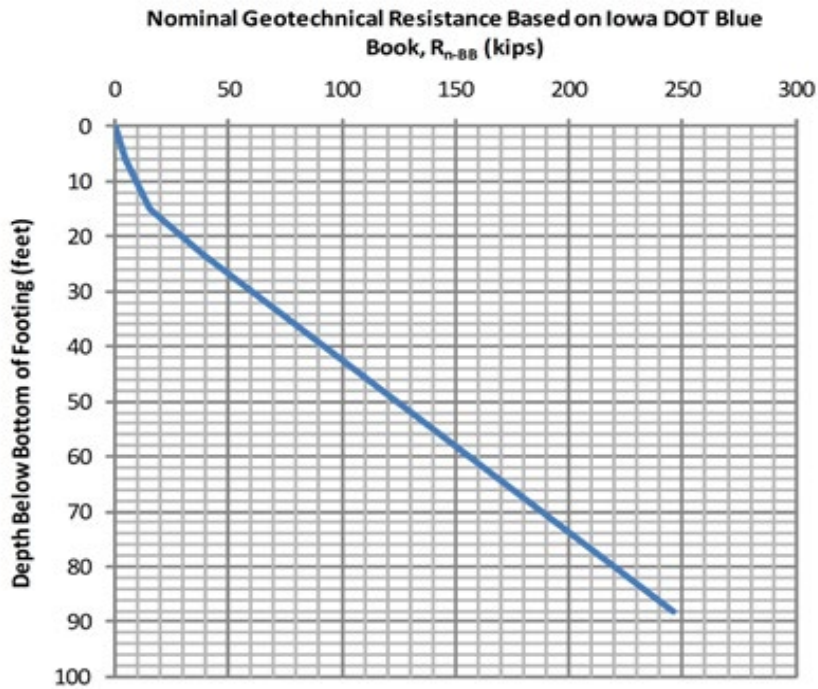

Track 2, Example 1-a plot of nominal geotechnical resistance versus depth

From the graph the depth below the footing necessary to achieve 213 kips is about 78 feet and may be computed as follows:

$$D_L = 23 + (213-38.0)/3.2 = 78 \text{ feet}$$

The contract pile length includes a 2-foot embedment in the footing [BDM Table 6.2.5] and a 1-foot allowance for cutoff due to driving damage [BDM 6.2.4.2].

$$L = 78 + 2 + 1 = 81 \text{ feet}$$

The length for steel H-piles is specified in 5-foot increments [BDM 6.2.4.2]. Therefore, the contract pile length is 80 feet, with 77 feet embedded.

At this point the embedded pile length is known, and it is necessary to check the resistance factor.

$$\% \text{ cohesive soil} = [(77-9)/77] (100) = 88\% > 70\%$$

Therefore, the resistance factor for cohesive soil is the correct choice.

The resistance factor, $\phi = 0.60$, is confirmed for estimating the contract pile length. If the resistance factor were incorrect, the engineer would need to repeat Steps 6 and 7 (although in this example the mixed soil classification would not result in numerical changes).

Step 8 - Estimate target nominal pile driving resistance, $R_{\text{ndr-T}}$

The complete embedment length below the bottom of footing will contribute to pile driving resistance. In addition to the required embedment length to achieve the nominal pile resistance, driving resistance would need to be added if part of the embedment length had been ignored to account for downdrag load or scour. Since there was no need to make allowance for downdrag load or scour in this example, the pile embedment length below bottom of footing will be the same as that considered to estimate the required nominal pile resistance.

The soil embedment length is 77 feet, which is equal to the 80 foot contract pile length minus the 2 feet of embedment length in the concrete footing and 1-foot cutoff.

For a driven H-pile with construction control based on the Iowa DOT ENR Formula at EOD and no planned retap, the following resistance factor, ϕ , is recommended to estimate the target nominal pile driving resistance for cohesive soil [BDM Table 6.2.9-3].

$\phi_{\text{TAR}} = 0.55$ for cohesive soil, averaged over the full depth of estimated pile penetration

The target pile driving resistance at End Of Drive (EOD) can be calculated as follows:

$$R_{\text{ndr-T}} = \frac{\sum \gamma Q + \gamma_{\text{DD}} \text{DD}}{\phi_{\text{TAR}}} = \frac{128 + 0}{0.55} = 233 \text{ kips/pile} = 117 \text{ tons/pile}$$

In Track 2, Example 1 in *Development of LRFD Procedures for Bridge Pile Foundations in Iowa – Volume IV: Design Guide and Track Examples* setup was included although the setup chart [BDM Figure 6.2.10] was developed for WEAP analysis only. Bureau policy is to consider setup only with H-piles in cohesive soils with WEAP construction control, and therefore setup should not be considered in this example.

It should be noted that construction control involving the Iowa DOT ENR Formula will require an increase in the target nominal driving resistance, $R_{\text{ndr-T}}$, over that required when a WEAP analysis is used for construction control. The target pile driving resistance at EOD here needed to be increased from 166 kips/pile for WEAP analysis (Track 1, Example 1) to 233 kips/pile due to a reduction in the statistical reliability of the construction control.

Step 9 – Prepare CADD notes for the bridge plans

At this point the final design engineer selects the appropriate CADD note and adds the specific pile load values to the notes [BDM 13.8.2].

E818: Abutment piles, LRFD contract length and resistance

THE CONTRACT LENGTH OF 80 FEET FOR THE WEST ABUTMENT PILES IS BASED ON A COHESIVE SOIL CLASSIFICATION, A TOTAL FACTORED AXIAL LOAD PER PILE (P_U) OF 128 KIPS, AND A GEOTECHNICAL RESISTANCE FACTOR (ϕ) OF 0.60.

THE NOMINAL AXIAL BEARING RESISTANCE FOR CONSTRUCTION CONTROL WAS DETERMINED FROM A COHESIVE SOIL CLASSIFICATION AND A GEOTECHNICAL RESISTANCE FACTOR (PHI) OF 0.55. PILES ARE ASSUMED TO BE DRIVEN FROM A START ELEVATION AT THE BOTTOM OF FOOTING.

E819: Abutment piles, driving and construction control

THE REQUIRED NOMINAL AXIAL BEARING RESISTANCE FOR WEST ABUTMENT PILES IS 117 TONS AT END OF DRIVE (EOD) OR RETAP. THE PILE CONTRACT LENGTH SHALL BE DRIVEN AS PER PLAN UNLESS PILES REACH REFUSAL. CONSTRUCTION CONTROL REQUIRES AN IOWA DOT ENR FORMULA.

Step 10 – Check the design

Policies for performing checks during design and after completion of design will vary among counties, cities, and engineering consultants.

-----**END DESIGN PHASE**-----

-----**BEGIN CONSTRUCTION PHASE**-----

Step 11 – Request and check contractor’s hammer data

The Contractor requested the Engineer’s approval for a DELMAG D19-42 single-acting diesel hammer to install the HP10×57 friction piles and supplied the following manufacturer’s information.

DELMAG D19-42

- Minimum rated energy = 22,721 foot-pounds (setting 1)
- Maximum rated energy = 31,715 foot-pounds (setting 2)
- Maximum rated energy = 37,868 foot-pounds (setting 3)
- Maximum rated energy = 47,335 foot-pounds (setting 4)
- Maximum obtainable stroke = 12.5 feet
- Ram weight = 4,189 pounds = 2.095 tons
- Drive anvil (cap) weight = 749 pounds = 0.375 tons
- Hammer weight (including trip device) = 8,400 pounds
- Hammer operating efficiency = 80 percent

Based on the Iowa DOT’s *Standard Specifications for Highway and Bridge Construction, Series 2012*, Appendix Table 2501.03-1, the minimum energy required for diesel hammers with 66 to 90-foot long HP10×57 piling is 29,000 foot-pounds; and the maximum energy allowed for diesel hammers is 40,000 foot-pounds for up to 65 foot long piles. Based on this information, the DELMAG D19-42 hammer was accepted, provided that the hammer was operated at fuel settings 2 or 3 (not 1 or 4).

Step 12 - Observe construction, record driven resistance, and resolve any construction issues

At EOD at the contract plan length, the construction inspector records the hammer stroke and number of blows per foot of pile penetration. This information is used with the following Iowa DOT ENR Formula to estimate driving resistance. The formula in *Standard Specifications for Highway and Bridge Construction, Series 2012*, Article 2501.03, M, 2, a, has been modified below (and will be revised accordingly in 2013) to remove the factor of safety so that the formula indicates nominal resistance.

$$R_{\text{ndr}} = \frac{12E}{S + 0.1} \times \frac{W}{W + M}$$

Where

R_{ndr} = nominal pile driving resistance, in tons.

W = weight of ram, in tons (unless the hammer has free fall, ram weight should be reduced IDOT SS 2501.03, M, 2, b, 1)).

M = weight of pile, drive cap (helmet, cushion, striker plate, and pile inserts if used), drive anvil, and follower (if applicable), in tons.

E = W x H = energy per blow, in foot-tons.

H = Hammer stroke, in feet.

S = average pile penetration in inches per blow for the last 10 blows.

12 = coefficient of 1 with feet-to-inch units conversion

For example, at EOD for the planned pile embedment length at an abutment pile, the construction inspector recorded a hammer stroke of 7-1/2 feet and a blow count of 31 blows/foot for the last foot of pile penetration.

Based on the guideline for the weight of ram in the Iowa DOT Standard Specifications noted above, the construction inspector reduced the weight of the ram to 4000 pounds or 2 tons. (The 189-pound reduction is an amount consistent with recent local practice. Note, however, the reduction recommended for WEAP analysis is 20%, which would amount to a larger, 838-pound reduction.)

For the D19-42 to drive HP10×57 piles,

Drive anvil weight = 749 pounds

Striker plate weight = 440 pounds

Helmet weight = 750 pounds

$$M = [(80 \times 57) + 749 + 440 + 750] = 6,499 \text{ pounds} = 3.25 \text{ tons}$$

$$S = (1/31) (12 \text{ in/ft}) = 0.39 \text{ inches/blow}$$

$$R_{\text{ndr}} = \frac{12WH}{S + 0.1} \times \frac{W}{W + M} = \frac{(12)(2.00)(7.5)}{(0.39 + 0.1)} \times \frac{(2.00)}{(2.00 + 3.25)} = \frac{180}{0.49} (0.38)$$

$$R_{\text{ndr}} = 140 \text{ tons} > 117 \text{ tons, OK}$$

(Considering the previous Iowa DOT ENR Formula that included a factor of safety of 4, R_{ndr} would equal $140/4 = 35$ tons.)

Computations in Track 2, Example 1 in *Development of LRFD Procedures for Bridge Pile Foundations in Iowa – Volume IV: Design Guide and Track Examples* are based on an efficiency of 80% (20% reduction). There are a couple of errors in the driving computations, but they generally show that the reduced efficiency results in lower computed values for R_{ndr} and a need for retap of one of the abutment piles.

Track 2, Example 2

Driven Timber Pile in Non-Cohesive Soil with Construction Control Based on Iowa DOT ENR Formula and No Planned Retap

General design and construction steps to be modified for project conditions

Design Steps	
Step 1	Develop bridge situation plan (or TS&L, Type, Size, and Location). ⁽¹⁾
Step 2	Develop soils package, including soil borings and foundation recommendations. ⁽¹⁾
Step 3	Determine pile layout, pile loads including downdrag, and other design requirements. ⁽¹⁾ This step includes structural checks.
Step 4	Estimate nominal geotechnical resistance for friction and end bearing.
Step 5	Select resistance factor(s) to estimate pile length based on the soil profile and construction control.
Step 6	Calculate required nominal pile resistance, R_n .
Step 7	Estimate contract pile length, L , considering downdrag, scour, pile uplift, lateral loading, and unbraced length, if applicable.
Step 8	Estimate target nominal pile driving resistance, R_{ndr-T} .
Step 9	Prepare CADD notes for bridge plans.
Step 10	Check the design. ⁽²⁾
Construction Steps	
Step 11	Request and check contractor's hammer data, and prepare bearing graph for WEAP control or other necessary items for alternate methods of construction control.
Step 12	Observe construction, record driven resistance, and resolve any construction issues.

(1) These steps determine the basic information for geotechnical pile design and will vary depending on bridge project and Bureau practice.

(2) Checking will vary depending on bridge project and Bureau practice.

Within the Bridges and Structures Bureau at the Iowa DOT the design steps that determine the basic information necessary for design of a pile generally follow as indicated in Track 1, Example 1. Because Track 2 will not be used by the Iowa DOT this example simply gives the basic information for the design. That information would be determined in various ways depending on the bridge owner (county or city) and any involved engineering consultants. The process generally should not affect the overall design of the pile. Because counties and cities typically follow state standards, this example contains references to the Bridge Design Manual [BDM].

Step 1 - Develop bridge situation plan (or TS&L, Type, Size, and Location)

An engineer involved in the bridge project plots topographical information, locates the bridge, determines general type of superstructure, location of substructure units, elevations of foundations, hydraulic information (if needed), and other basic information to characterize the bridge. The engineer then prepares a TS&L sheet that shows a plan and longitudinal section of

the bridge.

For this example for a non-state project, the TS&L gives the following information needed for design of the west abutment piles:

- 120-foot, three-span continuous concrete slab superstructure
- 30-foot roadway width
- 25-degree skew (custom designed, not a J-series bridge)
- Integral abutments which are standard practice for a bridge of this type and length [BDM 6.5.1.1.1]
- Pile foundation, no prebored holes (because the bridge length is less than 130 feet and there is no significant downdrag) [BDM 6.5.1.1.1]
- Bottom of west abutment footing elevation 922 feet

Step 2 - Develop soils information, including soil borings and foundation recommendations

Based on location of the abutments an engineer involved in the bridge project orders soil borings, typically at least one per substructure unit. When the engineer receives the boring logs he/she arranges for them to be plotted on a longitudinal section, checks any special geotechnical conditions on the site, and develops recommendations for foundation type with any applicable special design considerations.

Subsurface conditions at the abutment have been characterized based on a representative test boring. From the 922-foot elevation the abutment is underlain by 5 feet of soft to stiff silty clay ($N_a = 4$), 20 feet of fine sand ($N_a = 16$), 40 feet of medium sand ($N_a = 20$), and bouldery gravel and hard shale.

For this example, the recommendations are the following:

- Treated timber piles that tip out in the medium sand layer
- No significant downdrag
- Normal driving resistance
- No special site considerations for stability, settlement, or lateral movement (Therefore a Service I load will not be required for design.)
- Construction control based on the Iowa DOT ENR Formula (modified to remove factor of safety) with no planned retap

Step 3 - Determine pile layout, pile loads, and other design requirements. This step includes structural checks.

An engineer involved in the bridge project begins design of the abutment piles with the TS&L, boring logs, and foundation recommendations. The engineer selects treated timber piles for the county project.

There is no uplift, downdrag, or scour. Because the bridge characteristics fall within integral

abutment policy, the site has no unusual characteristics, the soils design engineer did not require further analysis, and construction will not be accelerated or delayed, there will be no need for lateral load or special analysis of the abutment piles. They may simply be designed for vertical load.

Notation: The same loads are designated in Step 3 with “P” and in Steps 6 and 8 with “Q”.

For the west abutment

$$\Sigma \eta \gamma P + \gamma_{DD} DD = 565 + 0 = 565 \text{ kips} = P_u$$

Based on indeterminate bending stresses at an integral abutment the Bridge Design Manual limits the nominal axial resistance for integral abutment piles. (A check of a typical pile cross section will give a larger nominal axial resistance.)

$$P_n = 64 \text{ kips [BDM 6.2.6.3]}$$

The AASHTO LRFD Specifications give the following resistance factor for axial compression [AASHTO-LRFD 8.5.2.2]. The engineer chooses not to increase the factor for a “highly redundant foundation” [AASHTO-LRFD C8.5.2.2].

$$\phi = 0.90$$

Required number of piles

$$n = P_u / \phi P_n = 565 / (0.90)(64) = 9.81, \text{ round to 10 piles}$$

Each pile then must carry

$$P_u = 565 / 10 = 56.5 \text{ kips}$$

The pile layout will be ten piles under the abutment plus one pile for each wing extension. (For the number of beams the designer checks the minimum number of piles, and for the abutment dimensions the designer checks the pile spacing guidelines [BDM 6.2.4.1]. Those checks are not shown here.) In this case the wing extension piles are added for abutment stability and are moderately loaded so they need not be checked for structural resistance.

Because the bridge characteristics fall within integral abutment policy, the site has no unusual characteristics, and construction will not be accelerated or delayed, there will be no need for lateral load or special analysis of the abutment piles. They may simply be designed for vertical load.

Step 4 - Estimate nominal geotechnical resistance per foot of pile embedment

Based on the west abutment soil boring and BDM Tables 6.2.7-1 and 6.2.7-2, the engineer estimates the following unit nominal resistances for end and friction bearing as shown in the

table below.

Track 2, Example 2-estimated nominal geotechnical resistance

Soil Stratum	Soil Description	Stratum Thickness (ft)	Average SPT N Value (blows/ft)	Estimated Unit Nominal Resistance for Friction Pile ^{(1), (2)} (kips/ft)	Cumulative Nominal Friction Resistance at Bottom of Stratum ⁽²⁾ (kips)	Estimated Nominal Resistance for End Bearing ^{(1), (2)} (kips)
1	Soft to Stiff Silty Clay	5	4	1.4	7.0	---
2	Fine Sand	20	16	2.4	55.0	---
3	Medium Sand	40	20	2.8	167.0	32

(1) Because the soil categories and N-values do not fit the geotechnical resistance charts exactly there is some judgment involved in selecting and interpolating for these values.

(2) This information is used to prepare the calculations in Step 7.

Step 5 - Select a resistance factor to estimate pile length based on the soil profile and construction control

Only the 5-foot Layer 1 of soft to stiff silty clay is classified as cohesive. The remainder of the profile is classified as non-cohesive, and most likely will represent more than 70% of the pile embedment length. Thus the soil is expected to fit the non-cohesive classification, and the resistance factor is selected from the choices below as 0.50 [BDM Table 6.2.9-1].

$\phi = 0.60$ for cohesive soil, averaged over the full depth of estimated pile penetration

$\phi = 0.60$ for mixed soil, averaged over the full depth of estimated pile penetration

$\phi = 0.50$ for non-cohesive soil, averaged over the full depth of estimated pile penetration

Step 6 - Calculate required nominal pile resistance, R_n

The required nominal pile resistance is:

$$R_n = \frac{\sum \eta \gamma Q + \gamma_{DD} DD}{\phi} = \frac{56.5 + 0}{0.50} = 113 \text{ kips/pile}$$

where,

$$\sum \eta \gamma Q = \gamma Q = 56.5 \text{ kips (Step 3)}$$

$$\gamma_{DDDD} = 0 \text{ (no downdrag)}$$

$$\phi = 0.50 \text{ (Step 5)}$$

The Blue Book, which summarized Iowa pile load tests, notes that in the majority of (static) load tests of timber piles, the piles yielded (began to settle more than the allowed amount) at no more than 75 tons (150 kips). The Blue Book also suggests that the “ultimate load” (nominal resistance) should not exceed 60 tons (120 kips) for short to medium piles. The required nominal resistance of 113 kips in this example is within that limit.

Step 7 – Estimate contract pile length, L

Based on the nominal resistance values in Step 4, the cumulative nominal geotechnical resistance, R_{n-BB} , per pile is calculated as follows, where D = depth in feet below the bottom of footing.

$$D_0 = 0 \text{ ft, } R_{n-BB0} = 0$$

$$D_1 = 5 \text{ ft, } R_{n-BB1} = R_{n-BB0} + (1.4 \text{ kips/ft}) (5 \text{ ft}) = 7.0 \text{ kips}$$

$$D_2 = 5 + 20 = 25 \text{ ft, } R_{n-BB2} = R_{n-BB1} + (2.4 \text{ kips/ft}) (20 \text{ ft}) = 7.0 + 48.0 = 55.0 \text{ kips}$$

$$\text{End bearing in Layer 3} = 32 \text{ kips, } R_{n-BB3} = R_{n-BB2} + 32 = 87.0 \text{ kips}$$

$$\text{Required additional length in Layer 3} = (113.0 - 87.0)/2.8 = 9.3 \text{ feet, round to 9 feet}$$

$$D_4 = 25 + 9 = 34 \text{ ft, } R_{n-BB4} = R_{n-BB3} + (2.8 \text{ kips/ft}) (9 \text{ ft}) = 87.0 + 25.2 \\ = 112.2 \text{ kips} \approx 113.0 \text{ kips}$$

The contract pile length includes a 2-foot embedment in the footing and a 1-foot allowance for cutoff due to driving damage.

$$L = 34 + 2 + 1 = 37 \text{ feet}$$

The length for timber piles is specified in 5-foot increments [BDM 6.2.4.2]. Therefore, the contract pile length is rounded to 35 feet.

At this point the embedded pile length is known, and it is necessary to check the site classification for the resistance factor.

$$\% \text{ non-cohesive soil} = [(32-5)/32] (100) = 84\% > 70\%$$

Therefore, $\phi = 0.50$ is confirmed for estimating the contract pile length. If the resistance factor were incorrect, the engineer would need to repeat Steps 6 and 7 (and in this example the change to mixed soil classification would increase the resistance factor and result in a shorter pile).

Step 8 - Estimate target nominal pile driving resistance, R_{ndr-T}

The complete embedment length below the bottom of footing will contribute to pile driving resistance. In addition to the required embedment length to achieve the nominal pile resistance, driving resistance would need to be added if part of the embedment length had been ignored to

account for downdrag load or scour. Since there was no need to make allowance for downdrag load or scour in this example, the pile embedment length below bottom of footing will be the same as that considered to estimate the required nominal pile resistance.

The soil embedment length is 32 feet, which is equal to the 35-foot contract pile length minus the 2 feet of embedment length in the concrete footing and 1-foot cutoff.

For a driven timber pile with construction control based on the Iowa DOT ENR Formula at EOD and no planned retap, the following resistance factor, ϕ , is recommended to estimate the target nominal pile driving resistance for cohesive soil [BDM Table 6.2.9-3, Table note (6)].

$$\phi_{\text{TAR}} = 0.35 \text{ for all soil types}$$

Therefore, the target nominal pile driving resistance can be calculated as follows:

$$R_{\text{ndr-T}} = \frac{\sum \gamma Q + \gamma_{\text{DD}} DD}{\phi_{\text{TAR}}} = \frac{56.5 + 0}{0.35} = 161 \text{ kips/pile} = 81 \text{ tons/pile}$$

It should be noted that construction control involving the Iowa DOT ENR Formula will require an increase in the target nominal driving resistance, $R_{\text{ndr-T}}$, over that required when a WEAP analysis is used for construction control. WEAP analysis would give $(56.5 + 0) / 0.40 = 141$ kips/pile or 71 tons/pile.

There also should be consideration of a driving limit less severe than the Iowa DOT definition of refusal, 160 blows/foot. The Iowa DOT has had a service driving limit of 40 tons to avoid overdriving [IDOT SS 2501.03, O, 2, c]. That limit with the Iowa DOT ENR Formula scales up to 160 tons. For one western Iowa bridge with soil conditions similar to this example, timber piles were driven to 40 tons or more, which was considered hard driving and, from the pile logs, seemed to be causing pile damage. At 40 tons formula-driven capacity, the penetration was about 0.22 inches per blow (or 55 blows/foot) for the last 10 blows. The number of blows per foot will vary based on several factors so 55 blows/foot is not necessarily an appropriate limit in all cases, and the Bureau now specifies a limit of 160 tons [BDM 6.2.6.3].

The Pile Driving Contractors Association (PDCA) has developed Specification 102-07, "Installation Specification for Driven Piles". C4.3.4 Practical Refusal states "In cases where the driving is easy until near the end of driving, a higher blow count may sometimes be satisfactory, but if a high blow count is required over a large percentage of the depth, even 10 blows per inch (or 120 blows/foot) may be too large. Blow counts greater than 10 blows per inch should be used with care, particularly with concrete or timber piles."

Step 9 – Prepare CADD note for bridge plans

At this point the final design engineer selects the appropriate CADD notes and adds the specific pile values to the notes.

E818: Abutment piles, LRFD contract length and resistance

THE CONTRACT LENGTH OF 35 FEET FOR THE WEST ABUTMENT PILES IS BASED ON A NON-COHESIVE SOIL CLASSIFICATION, A TOTAL FACTORED AXIAL LOAD PER PILE (P_U) OF 56.5 KIPS, AND A GEOTECHNICAL RESISTANCE FACTOR (ϕ) OF 0.50 FOR SOIL.

THE NOMINAL AXIAL BEARING RESISTANCE FOR CONSTRUCTION CONTROL WAS DETERMINED FROM A NON-COHESIVE SOIL CLASSIFICATION AND A GEOTECHNICAL RESISTANCE FACTOR (ϕ) OF 0.35 FOR SOIL. PILES ARE ASSUMED TO BE DRIVEN FROM A START ELEVATION AT THE BOTTOM OF FOOTING.

E819: Abutment piles, driving and construction control

THE REQUIRED NOMINAL AXIAL BEARING RESISTANCE FOR WEST ABUTMENT PILES IS 81 TONS AT END OF DRIVE OR RETAP. THE PILE CONTRACT LENGTH SHALL BE DRIVEN AS PER PLAN UNLESS PILES REACH A DRIVING LIMIT OF 160 TONS. CONSTRUCTION CONTROL REQUIRES AN IOWA DOT ENR FORMULA.

Step 10 – Check the design

Policies for performing checks during design and after completion of design will vary among counties, cities, and engineering consultants.

-----**END DESIGN PHASE**-----

-----**BEGIN CONSTRUCTION PHASE**-----

Step 11 – Request and check contractor’s hammer data

The Contractor requested the Engineer’s approval for a DELMAG D19 single-acting diesel hammer to install the timber piles and supplied the following manufacturer’s information.

DELMAG D19-42

- Minimum rated energy = 22,721 foot-pounds (setting 1)
- Maximum rated energy = 31,715 foot-pounds (setting 2)
- Maximum rated energy = 37,868 foot-pounds (setting 3)
- Maximum rated energy = 47,335 foot-pounds (setting 4)
- Maximum obtainable stroke = 12.13 feet
- Ram weight = 4,015 pounds = 2.007 tons
- Drive anvil (cap) weight = 753 pounds = 0.377 tons
- Driving cap weight = 1200 pounds = 0.60 tons
- Hammer weight (including trip device) = 8,715 pounds
- Hammer operating efficiency = 80 percent

Based on the Iowa DOT's *Standard Specifications for Highway and Bridge Construction, Series 2012*, Appendix Table 2501.03-1, the minimum energy required for diesel hammers with 35-foot long timber piling is 17,000 foot-pounds; and the maximum energy allowed for diesel hammers is 24,000 foot-pounds. Based on this information, the DELMAG D19 hammer was accepted at setting 1 (but not 2, 3, and 4). Note that gravity hammers can be used to install the timber piles. However, the minimum energy required for gravity hammers with 35-foot long timber piling is 15,000 foot-pounds; and the maximum energy allowed for gravity hammers is 25,000 foot-pounds.

Step 12 - Observe construction, record driven resistance, and resolve any construction issues

At EOD at the contract plan length, the construction inspector records the hammer stroke and number of blows per foot of pile penetration. This information is used with the following Iowa DOT ENR Formula to estimate driving resistance. The formula in *Standard Specifications for Highway and Bridge Construction, Series 2012*, Article 2501.03, M, 2, a, has been modified below (and will be revised accordingly in 2013) to remove the factor of safety so that the formula indicates nominal resistance.

$$R_{\text{ndr}} = \frac{12E}{S + 0.1} \times \frac{W}{W + M}$$

Where

R_{ndr} = nominal pile driving resistance, in tons.

W = weight of ram, in tons (unless the hammer has free fall, ram weight should be reduced IDOT SS 2501.03, M, 2, b, 1)).

M = weight of pile, drive cap (helmet, cushion, striker plate, and pile inserts if used), drive anvil, and follower (if applicable), in tons.

$E = W \times H$ = energy per blow, in foot-tons.

H = Hammer stroke, in feet.

S = average pile penetration in inches per blow for the last 10 blows.

12 = coefficient of 1 with feet-to-inch units conversion

For example, at EOD for the planned pile embedment length at Pile 1 in the Log of Piling Driven (not copied for this example), the construction inspector recorded a hammer stroke of 7-1/2 feet and a blow count of 20 blows/foot for the last foot of pile penetration.

Based on the guideline for the weight of ram in the Iowa DOT Standard Specifications noted above, the construction inspector reduced the weight of the ram to 3800 pounds or 1.90 tons. (The 215-pound reduction is an amount consistent with recent local practice. Note however, the reduction recommended for WEAP analysis is 20%, which would amount to a larger, 803-pound

reduction.)

The construction inspector used the formula to calculate a driving resistance of 133 tons as indicated below, which is greater than the target driving resistance of 81 tons.

$$W = 4015 - 215 = 3800 \text{ pounds or } 1.90 \text{ tons}$$

$$M = \text{pile} + \text{cap} + \text{anvil} = (1246 + 1200 + 753) / 2000 = 1.60 \text{ tons}$$

$$S = (1/20) (12 \text{ in/ft}) = 0.60 \text{ inches/blow}$$

$$R_{\text{ndr}} = \frac{12WH}{S + 0.1} \times \frac{W}{W + M} = \frac{(12)(1.90)(7.5)}{(0.60 + 0.1)} \times \frac{1.90}{(1.90 + 1.60)}$$
$$= 133 \text{ tons} > 81 \text{ tons, OK}$$

(Considering the previous Iowa DOT ENR Formula that included a factor of safety of 4, R_{ndr} would equal $133/4 = 33$ tons, more than the 20 tons required and therefore acceptable. Note that the required resistance is achieved by about the same overage factor for both LRFD and ASD. In this case then, under LRFD, it would require about the same blows per foot to achieve bearing as in the past.)

Track 3, Example 1

Driven H-Pile in Cohesive Soil with Construction Control Based on PDA/CAPWAP and Wave Equation with No Planned Retap

General design and construction steps to be modified for project conditions

Design Steps	
Step 1	Develop bridge situation plan (or TS&L, Type, Size, and Location). ⁽¹⁾
Step 2	Develop soils package, including soil borings and foundation recommendations. ⁽¹⁾
Step 3	Determine pile layout, pile loads including downdrag, and other design requirements. ⁽¹⁾ This step includes structural checks.
Step 4	Estimate nominal geotechnical resistance for friction and end bearing.
Step 5	Select resistance factor(s) to estimate pile length based on the soil profile and construction control.
Step 6	Calculate required nominal pile resistance, R_n .
Step 7	Estimate contract pile length, L , considering downdrag, scour, pile uplift, lateral loading, and unbraced length, if applicable.
Step 8	Estimate target nominal pile driving resistance, R_{ndr-T} .
Step 9	Prepare CADD notes for bridge plans.
Step 10	Check the design. ⁽²⁾
Construction Steps	
Step 11	Request and check contractor's hammer data, and prepare bearing graph for WEAP control or other necessary items for alternate methods of construction control.
Step 12	Observe construction, record driven resistance, and resolve any construction issues.

(1) These steps determine the basic information for geotechnical pile design and will vary depending on bridge project and Bureau practice.

(2) Checking will vary depending on bridge project and Bureau practice.

Within the Bridges and Structures Bureau at the Iowa DOT the design steps that determine the basic information necessary for design of a steel H-pile generally follow as indicated in Steps 1-3. The steps involve communication among the preliminary design engineer, soils design engineer, and final design engineer. In other organizations the basic information may be determined differently, but that process generally should not affect the overall design of the pile.

Step 1 - Develop bridge situation plan (or TS&L, Type, Size, and Location)

For a typical bridge the preliminary design engineer plots topographical information, locates the bridge, determines general type of superstructure, location of substructure units, elevations of foundations, hydraulic information (if needed), and other basic information to characterize the bridge. The preliminary design engineer then prepares a TS&L sheet that shows a plan and longitudinal section of the bridge.

For this example for a state project with special construction control, the TS&L gives the

following information needed for design of abutment piles:

- 120-foot single span, prestressed concrete beam superstructure
- Zero skew
- Integral abutments (because these are standard practice for non-skewed concrete bridges less than 575 feet in length with end or single spans not exceeding the length of standard prestressed concrete beams) [BDM 6.5.1.1.1]
- Pile foundations, no prebored holes (because the bridge length is less than 130 feet) [BDM 6.5.1.1.1]
- Bottom of abutment footing elevation 433 feet

Step 2 - Develop soils package, including soil borings and foundation recommendations

Based on location of the abutments the soils design engineer orders soil borings, typically at least one per substructure unit. When the engineer receives the boring logs he/she arranges for them to be plotted on a longitudinal section, checks any special geotechnical conditions on the site, and writes a recommendation for foundation type with any applicable special design considerations.

For this example, the soils design engineer recommends the following:

- Friction piles that tip out in the firm glacial clay layer
- Steel H-piles for the integral abutments
- Structural Resistance Level – 1 (which does not require a driving analysis by the Construction and Materials Bureau during design [BDM 6.2.6.1])
- Normal driving resistance (This will lead to $\phi_c = 0.60$ for the structural check.)
- No special site considerations for stability, settlement, or lateral movement (Therefore the Service I load will not be required for design.)
- Construction control based on PDA/CAPWAP and wave equation with no planned retap

The soil profile shown below includes the following soil boring at the west abutment. Generally below the bottom of footing elevation there are three layers: 6 feet of soft silty clay, 9 feet of silty sand, and firm glacial clay to the bottom of the boring at 95 feet. Layer 3 is subdivided at a depth of 30 feet because of a step-increase in nominal friction resistance at that elevation [BDM Table 6.2.7-2]. No groundwater was encountered in the boring.

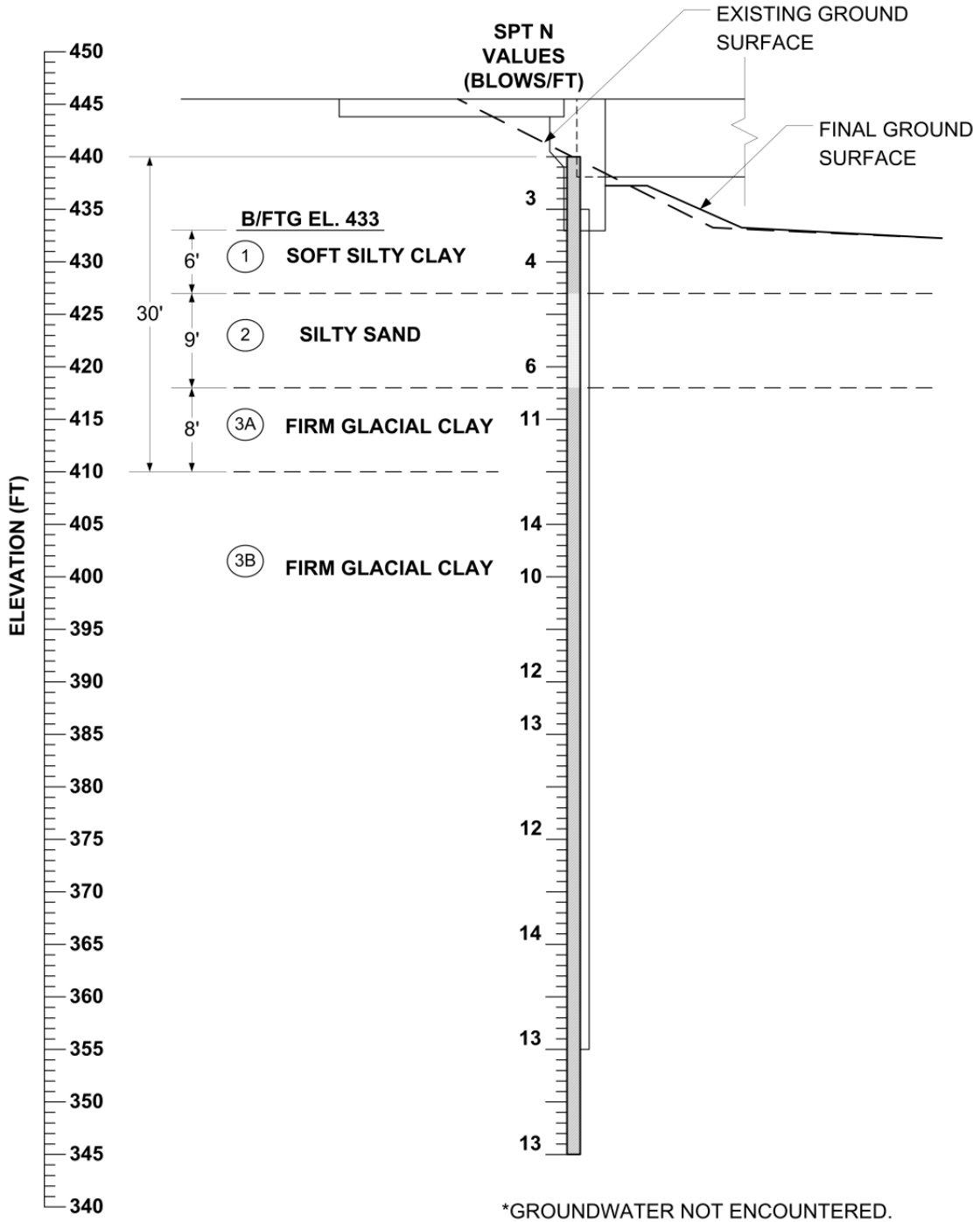

Track 3, Example 1-soil profile at west abutment

Step 3 - Determine pile layout, pile loads, and other design requirements. This step includes structural checks.

The final design engineer begins design of the abutment piles with the TS&L and the soils design package. Because the bridge has a prestressed concrete beam superstructure and integral abutments the engineer selects HP 10×57 piles, following Bridge Design Manual policy [BDM 6.5.1.1.1].

There is no uplift, downdrag, or scour. Because the bridge characteristics fall within integral abutment policy, the site has no unusual characteristics, the soils design engineer did not require further analysis, and construction will not be accelerated or delayed, there will be no need for lateral load or special analysis of the abutment piles. They may simply be designed for vertical load.

Notation: The same loads are designated in Step 3 with “P” and in Steps 6 and 8 with “Q”.

For the west abutment

$$\Sigma \eta \gamma P + \gamma_{DD} DD = 895 + 0 = 895 \text{ kips} = P_u$$

The soils package indicates normal driving resistance, therefore

$$\phi_c = 0.60$$

The soils engineer recommends SRL-1 for which

$$P_n = 243 \text{ kips [BDM Table 6.2.6.1-1]}$$

Considering the TS&L and other project factors the final design engineer selects BTC beams [BDM Table 5.4.1.1.1]. For integral abutments with BTC beams and prebored holes for the piles, the maximum $P_n = 365$ kips [BDM Table 6.5.1.1.1-1]. With the short span, the prebored holes are not necessary and, for this project, 365 kips would be the limit per integral abutment pile. The SRL-1 value controls, however.

Required number of piles

$$n = P_u / \phi P_n = 895 / (0.60)(243) = 6.14, \text{ round to 7 piles}$$

Each pile then must carry

$$P_u = 895 / 7 = 128 \text{ kips}$$

The pile layout will be seven piles under the abutment plus one pile for each wing extension as shown below. (For the number of beams the designer checks the minimum number of piles, and for the abutment dimensions the designer checks the pile spacing guidelines [BDM 6.2.4.1]. Those checks are not shown here.) In this case the wing extension piles are added for abutment stability and are moderately loaded so they need not be checked for structural resistance.

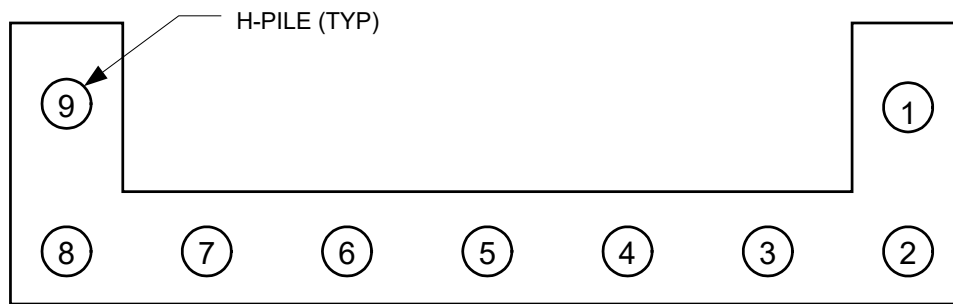

Track 3, Example 1-pile layout at west abutment

Step 4 - Estimate nominal geotechnical resistance for friction

Based on the west abutment soil boring and BDM Table 6.2.7-2, the final design engineer estimates the following nominal unit resistances for friction bearing.

Track 3, Example 1-estimated nominal unit geotechnical resistance

Soil Stratum	Soil Description		Stratum Thickness (ft)	Average SPT N Value (blows/ft)	Estimated Unit Nominal Resistance for Friction Pile (kips/ft)
1	Soft Silty Clay		6	4	0.8
2	Silty Sand		9	6	1.2
3A	Firm Glacial Clay	within 30 feet of natural ground elevation	8	11	2.8
3B		more than 30 feet below natural ground elevation	65	12	3.2

The firm glacial clay stratum has been divided into two parts, to delineate the embedded pile length that is within 30 feet of the natural ground surface as noted in the BDM geotechnical resistance chart [BDM Table 6.2.7-2]. Application of the chart to estimate the nominal resistance values is illustrated on the next page. Note that the SPT N values are too small for use of end bearing in Layer 3B [BDM Table 6.2.7-1].

Track 3, Example 1-BDM geotechnical resistance chart [BDM Table 6.2.7-2]

SOIL DESCRIPTION	BLOW COUNT		ESTIMATED NOMINAL RESISTANCE VALUES FOR FRICTION PILE IN KIPS PER FOOT											
	N-VALUE		WOOD PILE	STEEL "H"			PRESTRESSED			STEEL PIPE				
	MEAN	RANGE		10	12	14	12	14	16	10	12	14	18	
Alluvium or Loess														
Very soft silty clay	1	0 - 1	0.8	0.4	0.8	0.8	0.8	0.8	0.8	0.8	0.4	0.4	0.4	0.8
Soft silty clay	3	2 - 4	1.2	0.8	1.2	1.2	0.8	0.8	0.8	0.8	0.8	0.8	0.8	1.2
Stiff silty clay	6	4 - 8	1.6	1.2	1.6	2.0	1.2	1.6	2.0	1.2	1.2	1.6	2.0	2.0
Firm silty clay	11	7 - 15	2.4	2.0	2.4	2.8	2.4	2.8	3.2	1.6	2.0	2.4	2.8	2.8
Stiff silt	6	3 - 7	1.6	1.2	1.6	1.6	1.6	1.6	1.6	1.2	1.2	1.6	1.6	1.6
Stiff sandy silt	6	4 - 8	1.6	1.2	1.6	1.6	1.6	1.6	1.6	1.2	1.2	1.6	1.6	1.6
Stiff sandy clay	6	4 - 8	1.6	1.2	1.6	2.0	2.0	2.0	2.4	1.2	1.6	1.6	2.0	2.0
Silty sand	8	3 - 13	1.2	1.2	1.2	1.6	1.6	1.6	1.6	0.8	0.8	1.2	1.6	1.6
Clayey sand	13	6 - 20	2.0	1.6	2.0	2.8	2.4	2.4	2.8	1.6	2.0	2.4	2.8	2.8
Fine sand	15	8 - 22	2.4	2.0	2.4	2.8	2.4	2.8	3.2	1.6	2.0	2.4	2.8	2.8
Coarse sand	20	12 - 28	3.2	2.8	3.2	3.6	3.2	3.6	4.0	2.0	2.4	2.8	3.6	3.6
Gravelly sand	21	11 - 31	3.2	2.8	3.2	3.6	3.6	3.6	4.0	2.0	2.4	2.8	3.6	3.6
Granular material	> 40	---	(2)	4.0	4.8	5.6	(2)	(2)	(2)	(2)	(2)	(2)	(2)	(2)
Glacial Clay														
Firm silty glacial clay	11	7 - 15	2.8	2.4	2.8	3.2	2.8	3.2	3.6	2.0	2.4	2.4	3.2	3.2
Firm clay (gumbotil)	12	9 - 15	2.8	2.4	2.8	3.2	2.8	3.2	3.6	2.0	2.4	2.4	3.2	3.2
Firm glacial clay ⁽¹⁾	11	7 - 15	2.4	2.8	3.2	3.6	3.2	3.6	4.0	2.0	2.4	2.8	3.6	3.6
			[3.2]	[3.2]	[4.0]	[4.4]	[4.0]	[4.4]	[4.8]	[2.4]	[2.8]	[3.2]	[4.4]	[4.4]
Firm sandy glacial clay ⁽¹⁾	13	9 - 15	2.4	2.8	3.2	3.6	3.2	3.6	4.0	2.0	2.4	2.8	3.6	3.6
			[3.2]	[3.2]	[4.0]	[4.4]	[4.0]	[4.4]	[4.8]	[2.4]	[2.8]	[3.2]	[4.4]	[4.4]
Firm - very firm glacial clay ⁽¹⁾	14	11 - 17	2.8	2.8	3.2	3.6	4.0	4.4	4.8	2.4	2.8	3.2	4.0	4.0
			[3.6]	[4.0]	[4.8]	[5.6]	[4.8]	[5.2]	[5.6]	[3.2]	[3.6]	[4.0]	[5.2]	[5.2]
Very firm glacial clay ⁽¹⁾	24	17 - 30	2.8	2.8	3.2	3.6	3.2 ⁽³⁾	3.6 ⁽³⁾	4.4 ⁽³⁾	2.4	2.8	3.2	4.0	4.0
			[3.6]	[4.0]	[4.8]	[5.6]	[4.8]	[5.6]	[6.4]	[3.2]	[3.6]	[4.0]	[5.2]	[5.2]
Very firm sandy glacial clay ⁽¹⁾	25	15 - 30	3.2	2.8	3.2	3.6	3.2 ⁽³⁾	3.6 ⁽³⁾	4.4 ⁽³⁾	2.4	2.8	3.2	4.0	4.0
			[4.0]	[4.0]	[4.8]	[5.6]	[4.8]	[5.6]	[6.4]	[3.2]	[3.6]	[4.0]	[5.2]	[5.2]
Cohesive or glacial material ⁽¹⁾	> 35	---	(2)	2.8	3.2	3.6	(2)	(2)	(2)	2.0 ⁽⁴⁾	2.4 ⁽⁴⁾	2.8 ⁽⁴⁾	3.6 ⁽⁴⁾	3.6 ⁽⁴⁾
				[4.0]	[4.8]	[5.6]				[3.2]	[4.0]	[4.4]	[5.6]	[5.6]

Table notes:

- (1) For double entries the upper value is for an embedded pile within 30 feet of the natural ground elevation, and the lower value [] is for pile depths more than 30 feet below the natural ground elevation.
- (2) Do not consider use of this pile type for this soil condition, wood with N > 25, prestressed concrete with N > 35, or steel pipe with N > 40.
- (3) Prestressed concrete piles have proven to be difficult to drive in these soils. Prestressed piles should not be driven in glacial clay with consistent N > 30 to 35.
- (4) Steel pipe piles should not be driven in soils with consistent N > 40.

Step 5 - Select resistance factor to estimate pile length based on the soil profile and construction control

In this step the final design engineer first characterizes the site as cohesive, mixed, or non-cohesive based on soil classification in the table below and the soil profile.

Track 3, Example 1-soil classification table [BDM Table 6.2.8]

Generalized Soil Category	Soil Classification Method			
	AASHTO	USDA Textural	BDM 6.2.7 Geotechnical Resistance Charts	
Cohesive	A-4, A-5, A-6 and A-7	Clay Silty clay Silty clay loam Silt Clay loam Silt loam Loam Sandy clay	Loess	Very soft silty clay
				Soft silty clay
				Stiff silty clay
				Firm silty clay
				Stiff silt
			Glacial Clay	Firm silty glacial clay
				Firm clay (gumbotil)
				Firm glacial clay
				Firm sandy glacial clay
				Firm-very firm glacial clay
				Very firm glacial clay
				Very firm sandy glacial clay
				Cohesive or glacial material
				Alluvium Or Loess
Silty sand				
Clayey sand				
Fine sand				
Coarse sand				
Gravelly sand				
Granular material (N>40)				
Non-Cohesive	A-1, A-2 and A-3	Sandy clay loam Sandy loam Loamy sand Sand	Alluvium Or Loess	Stiff sandy silt
				Silty sand
				Clayey sand
				Fine sand
				Coarse sand
				Gravelly sand
				Granular material (N>40)

Only the 9-foot Layer 2 of silty sand is classified as non-cohesive. The remainder of the profile is classified as cohesive, and most likely will represent more than 70% of the pile embedment length. Thus the soil is expected to fit the cohesive classification, and the resistance factor selection from the three available choices below is 0.70 [BDM Table 6.2.9-1].

$\phi = 0.70$ for cohesive soil, averaged over the full depth of estimated pile penetration

$\phi = 0.70$ for mixed soil, averaged over the full depth of estimated pile penetration

$\phi = 0.60$ for non-cohesive soil, averaged over the full depth of estimated pile penetration

Step 6 - Calculate the required nominal pile resistance, R_n

The required nominal pile resistance is:

$$R_n = \frac{\sum \eta \gamma Q + \gamma_{DD} DD}{\phi} = \frac{128 + 0}{0.70} = 183 \text{ kips/pile}$$

where,

$$\sum \eta \gamma Q = \gamma Q = 128 \text{ kips (Step 3)}$$

$$\gamma_{DD} DD = 0 \text{ (no downdrag)}$$

$$\phi = 0.70 \text{ (Step 5)}$$

Step 7 – Estimate contract pile length, L

Based on the nominal resistance values in Step 4, the cumulative nominal geotechnical resistance, R_{n-BB} , per pile is calculated as follows, where D = depth in feet below the bottom of footing.

$$D_0 = 0 \text{ ft, } R_{n-BB0} = 0$$

$$D_1 = 6 \text{ ft, } R_{n-BB1} = R_{n-BB0} + (0.8 \text{ kips/ft}) (6 \text{ ft}) = 4.8 \text{ kips}$$

$$D_2 = 6 + 9 = 15 \text{ ft, } R_{n-BB2} = R_{n-BB1} + (1.2 \text{ kips/ft}) (9 \text{ ft}) = 4.8 + 10.8 = 15.6 \text{ kips}$$

$$D_3 = 15 + 8 = 23 \text{ ft, } R_{n-BB3} = R_{n-BB2} + (2.8 \text{ kips/ft}) (8 \text{ ft}) = 15.6 + 22.4 = 38.0 \text{ kips}$$

$$D_4 = 23 + 65 = 88 \text{ ft, } R_{n-BB4} = R_{n-BB3} + (3.2 \text{ kips/ft}) (65 \text{ ft}) = 38.0 + 208.0 = 246.0 \text{ kips}$$

(The 246.0 kips is for graphing purposes only and exceeds the required nominal resistance of a pile.)

A graphic presentation of the estimated nominal geotechnical resistance per pile versus depth is presented below.

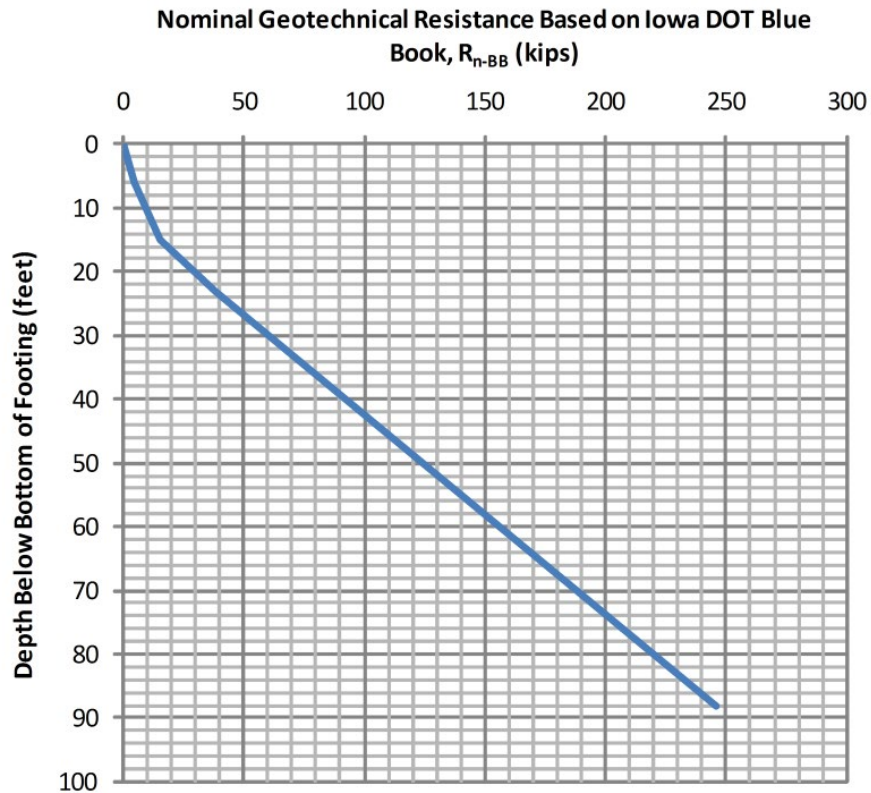

Track 3, Example 1-a plot of nominal geotechnical resistance versus depth

From the graph the depth below the footing necessary to achieve 183 kips is about 68 feet and may be computed as follows:

$$D_L = 23 + (183-38.0)/3.2 = 68 \text{ feet}$$

The contract pile length includes a 2-foot embedment in the footing [BDM Table 6.2.5] and a 1-foot allowance for cutoff due to driving damage [BDM 6.2.4.2].

$$L = 68 + 2 + 1 = 71 \text{ feet}$$

The length for steel H-piles is specified in 5-foot increments [BDM 6.2.4.2]. Therefore, the contract pile length is 70 feet, with 67 feet embedded.

At this point the embedded pile length is known, and it is necessary to check the for resistance factor.

$$\% \text{ cohesive soil} = [(67-9)/67] (100) = 87\% > 70\%$$

Therefore, the resistance factor for cohesive soil is the correct choice. If the resistance factor were incorrect, the engineer would need to repeat Steps 6 and 7 (although in this example the mixed soil classification would not result in numerical changes).

Step 8 - Estimate target nominal pile driving resistance, R_{ndr-T}

For a driven H-pile with no planned retap and use of PDA/CAPWAP and WEAP analysis for construction control, the following resistance factors, ϕ , are recommended to estimate the target nominal pile driving resistance [BDM Table 6.2.9-3].

$\phi_{EOD} = 0.75$ for cohesive soil, averaged over the full depth of estimated pile penetration

$\phi_{SETUP} = 0.40$ for cohesive soil, averaged over the full depth of estimated pile penetration

$\phi = 0.70$ for mixed soil, averaged over the full depth of estimated pile penetration

$\phi = 0.70$ for non-cohesive soil, averaged over the full depth of estimated pile penetration

For a normal construction schedule, pile setup at one day is the most appropriate choice. Therefore, the nominal pile resistance during construction, R_n , will be determined at end of drive by scaling back setup gain, and then adjusting retaps to account for setup.

$$\Sigma\eta\gamma Q + \gamma_{DD}DD \leq \phi R_n \text{ where } \eta = \text{load modifier} = 1.0 \text{ from BDM 6.2.3.1}$$

Let $R_n = R_T$ = nominal pile resistance at time T (days) after EOD.

$$R_{EOD} \geq \frac{\Sigma\eta\gamma Q + \gamma_{DD}DD}{\phi_{EOD} + \phi_{SETUP}(F_{SETUP} - 1)}$$

where,

$$\Sigma\eta\gamma Q = \gamma Q = 128 \text{ kips, (Step 2)}$$

$$\gamma_{DD}DD = 0 \text{ (no downdrag)}$$

$$F_{SETUP} = \text{Setup Ratio} = R_T/R_{EOD}$$

To determine the setup ratio the soil profile was used to calculate the average SPT N-value for cohesive soil penetrated by the driven pile over the contract pile length, as follows.

$$\text{Calculated average SPT N-value} = [(6')(4) + (8')(11) + (67'-23')(12)]/(67'-9') = 11$$

The average SPT N-value of 11 yields a Setup Ratio, F_{SETUP} , of 1.61 for 1-day retap, 1.55 for 3-day retap, and 1.61 for 7-day retap from the graph shown below [BDM Figure 6.2.10].

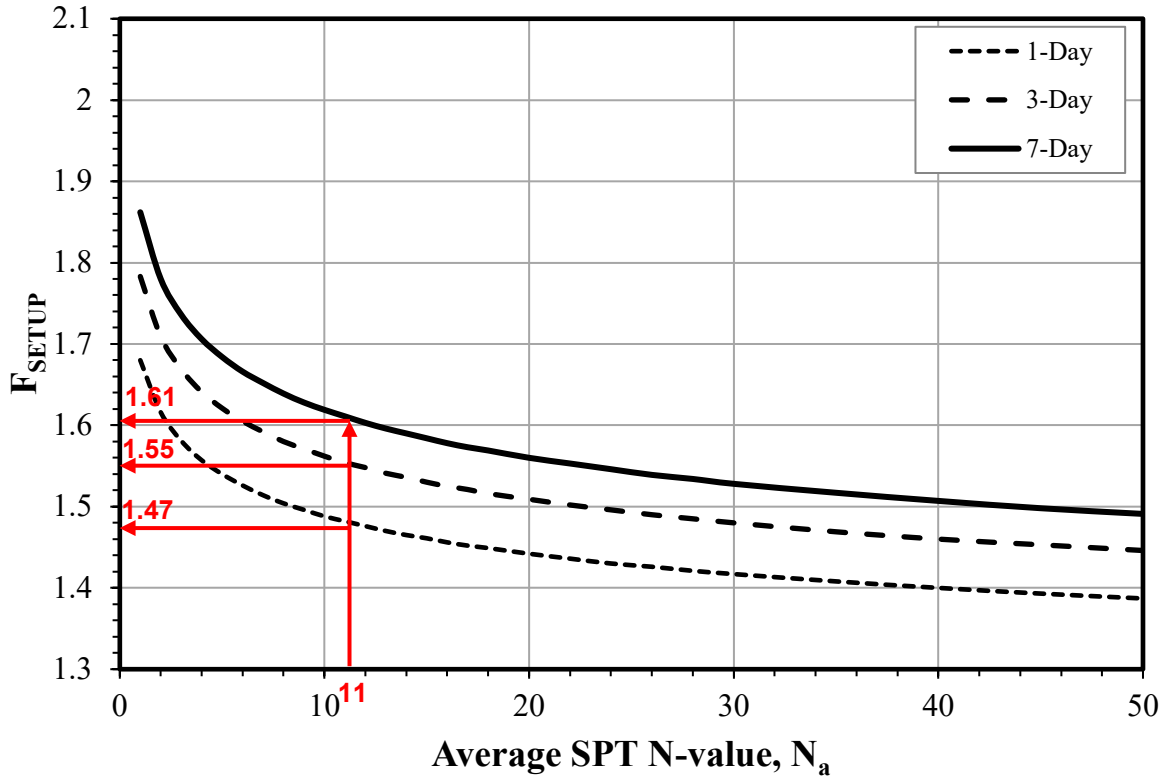

Track 3, Example 1-pile setup factor chart [BDM Figure 6.2.10]

Let ϕ_{TAR} = Resistance factor for target nominal resistance ≤ 1.00

$$= \phi_{EOD} + \phi_{SETUP}(F_{SETUP} - 1)$$

and $R_{ndr-T} = R_{EOD}$

The target pile driving resistance at End Of Drive is

$$\begin{aligned}
 R_{ndr-T} &= R_{EOD} \\
 &\geq \frac{\sum \eta \gamma Q + \gamma_{DD} DD}{\phi_{TAR}} \\
 &\geq \frac{\sum \eta \gamma Q + \gamma_{DD} DD}{\phi_{EOD} + \phi_{SETUP}(F_{SETUP} - 1)} \\
 &\geq \frac{128 + 0}{(0.75) + (0.40)(1.61 - 1)} = \frac{128}{0.99} \\
 &= 129 \text{ kips/pile} = 65 \text{ tons/pile}
 \end{aligned}$$

Note that $\phi_{TAR} < 1.00$, OK

The target nominal geotechnical resistance at 1-day retap then is:

$R_{1\text{-day}} = (129.0)(1.47) = 189.6 \text{ kips} = 95 \text{ tons}$, but not more than $R_{\text{ndr-T}}$ computed with ϕ_{EOD} , not considering setup.

$R_{1\text{-day}} \leq (128 + 0)/0.75 = 170.7 \text{ kips} = 85 \text{ tons}$

The 85 tons controls and also will control 3-day and 7-day retaps (which otherwise would be 100 tons and 104 tons, respectively).

Step 9 – Prepare CADD notes for the bridge plans

At this point the final design engineer selects the appropriate CADD note and adds the specific pile load values to the notes [BDM 13.8.2].

E818: Abutment piles, LRFD contract length and resistance

THE CONTRACT LENGTH OF 70 FEET FOR THE WEST ABUTMENT PILES IS BASED ON A COHESIVE SOIL CLASSIFICATION, A TOTAL FACTORED AXIAL LOAD PER PILE (P_U) OF 128 KIPS, AND A GEOTECHNICAL RESISTANCE FACTOR (ϕ) OF 0.75.

THE NOMINAL AXIAL BEARING RESISTANCE FOR CONSTRUCTION CONTROL WAS DETERMINED FROM A COHESIVE SOIL CLASSIFICATION AND A GEOTECHNICAL RESISTANCE FACTOR (ϕ) OF 0.99. PILES ARE ASSUMED TO BE DRIVEN FROM A START ELEVATION AT THE BOTTOM OF FOOTING.

E819: Abutment piles, driving and construction control

THE REQUIRED NOMINAL AXIAL BEARING RESISTANCE FOR WEST ABUTMENT PILES IS 65 TONS AT END OF DRIVE. IF RETAPS ARE NECESSARY TO ACHIEVE BEARING, THE REQUIRED NOMINAL AXIAL BEARING RESISTANCE IS 85 TONS AT ONE-DAY OR LATER RETAPS. THE PILE CONTRACT LENGTH SHALL BE DRIVEN AS PER PLAN UNLESS PILES REACH REFUSAL. CONSTRUCTION CONTROL REQUIRES PDA/CAPWAP AND A WEAP ANALYSIS WITH BEARING GRAPH.

Step 10 – Check the design

Within the Bridges and Structures Bureau at the Iowa DOT a final design engineer other than the bridge designer is assigned to give the bridge design an independent check at the time final plans are complete. During the checking process a final design engineer will review the soils package to ensure that all recommendations were followed and also will check structural, geotechnical,

and drivability aspects of the design.

Other design organizations may perform checks at various stages of design rather than upon plan completion.

-----**END DESIGN PHASE**-----

-----**BEGIN CONSTRUCTION PHASE**-----

Step 11 – Request and check contractor’s hammer data, and prepare bearing graph

After the bridge contract is let and prior to start of pile driving, the contractor completes Hammer Data sheets for the pile driving hammer that he/she plans to use. The Hammer Data sheets include all pertinent information including the cap (helmet) number and hammer identification information with details, hammer cushion, and pile cushion (where required), as well as pile size, pile length, and estimated pile driving resistance. The Construction and Materials Bureau uses the data received to complete a WEAP analysis for construction control during pile driving. Results from the WEAP analysis are then used to prepare an LRFD Bearing Graph (without the factor of safety used for allowable stress design). The Bearing Graph includes curves of nominal driving resistance versus blows per foot, and identifies specific driving conditions, where driving stress is a concern.

Step 12 - Observe construction, record driven resistance, and resolve any construction issues

During pile driving, the construction inspector performs PDA analysis with CAPWAP signal processing. Pile stress and movement are monitored, and driving resistance is calculated in real time to verify that the pile reaches target driving resistance. The construction inspector enters the EOD information on the driving log.

If the recorded pile driving resistance at EOD is less than the target pile nominal driving resistance, the pile is retapped with PDA/CAPWAP about 24 hours after EOD. (The retap is a remedial measure that makes use of setup for an individual pile. If the 24-hour retap does not indicate enough driven resistance, an extension will be added the same day rather than wait to retap another day.)

Track 3, Example 2

Driven H-Pile in Cohesive Soil and Construction Control Based on Wave Equation and Planned Retap at 3 Days

General design and construction steps to be modified for project conditions

Design Steps	
Step 1	Develop bridge situation plan (or TS&L, Type, Size, and Location). ⁽¹⁾
Step 2	Develop soils package, including soil borings and foundation recommendations. ⁽¹⁾
Step 3	Determine pile layout, pile loads including downdrag, and other design requirements. ⁽¹⁾ This step includes structural checks.
Step 4	Estimate nominal geotechnical resistance for friction and end bearing.
Step 5	Select resistance factor(s) to estimate pile length based on the soil profile and construction control.
Step 6	Calculate required nominal pile resistance, R_n .
Step 7	Estimate contract pile length, L , considering downdrag, scour, pile uplift, lateral loading, and unbraced length, if applicable.
Step 8	Estimate target nominal pile driving resistance, R_{ndr-T} .
Step 9	Prepare CADD notes for bridge plans.
Step 10	Check the design. ⁽²⁾
Construction Steps	
Step 11	Request and check contractor's hammer data, and prepare bearing graph for WEAP control or other necessary items for alternate methods of construction control.
Step 12	Observe construction, record driven resistance, and resolve any construction issues.

(1) These steps determine the basic information for geotechnical pile design and will vary depending on bridge project and Bureau practice.

(2) Checking will vary depending on bridge project and Bureau practice.

Within the Bridges and Structures Bureau at the Iowa DOT the design steps that determine the basic information necessary for design of a steel H-pile generally follow as indicated in Steps 1-3. The steps involve communication among the preliminary design engineer, soils design engineer, and final design engineer. In other organizations the basic information may be determined differently, but that process generally should not affect the overall design of the pile.

Step 1 - Develop bridge situation plan (or TS&L, Type, Size, and Location)

For a typical bridge the preliminary design engineer plots topographical information, locates the bridge, determines general type of superstructure, location of substructure units, elevations of foundations, hydraulic information (if needed), and other basic information to characterize the bridge. The preliminary design engineer then prepares a TS&L sheet that shows a plan and longitudinal section of the bridge.

For this example for a state project with special construction control, the TS&L gives the

following information needed for design of abutment piles:

- Three span, 240-foot prestressed concrete beam superstructure
- Seven D-beam cross section
- Zero skew
- Integral abutments
- Pile foundations with 10-foot prebored holes
- Bottom of west abutment footing at natural ground elevation

Step 2 - Develop soils package, including soil borings and foundation recommendations

Based on locations of the abutments the soils design engineer orders soil borings, typically at least one per substructure unit. When the engineer receives the boring logs he/she arranges for them to be plotted on a longitudinal section, checks any special geotechnical conditions on the site, and writes a recommendation for foundation type with any applicable special design considerations.

For this example, the soils design engineer recommends the following:

- Piles driven into very firm glacial clay
- Steel H-piles for the integral abutments
- Structural Resistance Level – 1 (which does not require a driving analysis by the Construction and Materials Bureau during design [BDM 6.2.6.1]. SRL-1 in this case allows the designer to consider both friction and end bearing.)
- Normal driving resistance (This will lead to $\phi_c = 0.60$ for the structural check.)
- No special site considerations for stability, settlement, or lateral movement (Therefore a Service I load will not be required for design.)
- Standard construction control based on WEAP analysis with 3-day planned retap (At present the planned retap is not usual Iowa DOT practice.)

The soil profile is as follows. Note that the top of Stratum 3 falls at the elevation of 30 feet below natural ground. Below 30 feet the friction resistance increases [BDM Table 6.2.7-2].

- Stratum 1, topsoil 3 feet;
- Stratum 2, firm glacial clay 27 feet, average N-value = 11; and
- Stratum 3, very firm glacial clay 50 feet, average N-value = 25.

Step 3 - Determine pile layout, pile loads, and other design requirements. This step includes structural checks.

The final design engineer begins design of the abutment piles with the TS&L and the soils design package. Because the bridge has a prestressed concrete beam superstructure and integral abutments, the engineer selects HP 10×57 piles, following Bridge Design Manual policy [BDM 6.5.1.1.1].

Notation: The same loads are designated in Step 3 with “P” and in Steps 6 and 8 with “Q”.

Based on total Strength I abutment load and Bridge Design Manual policy for pile spacing and number of piles [BDM 6.5.4.1.1], the final design engineer determines the following:

- Strength I factored load for abutment (not including wing extension) piles = 900 kips
- Nominal structural resistance per pile at SRL-1 = 243 kips [BDM Table 6.2.6.1-1]
- Nominal maximum structural resistance for an integral abutment pile with 10-foot prebore = 365 kips [BDM Table 6.5.1.1.1-1], but the SRL-1 nominal resistance of 243 kips controls
- Minimum number of piles based on structural resistance = $900/(0.6)(243) = 6.17$, rounded up to 7
- Minimum number of piles based on superstructure cross section: 7 beams, therefore 7 piles [BDM 6.2.4.1]. (The designer also needs to check minimum and maximum pile spacing guidelines in BDM 6.2.4.1.)
- Seven piles with two wing extension piles as shown in the figure, if geotechnical resistance is sufficient
- Strength I factored load per abutment pile, $P_u = 900/7 = 129$ kips

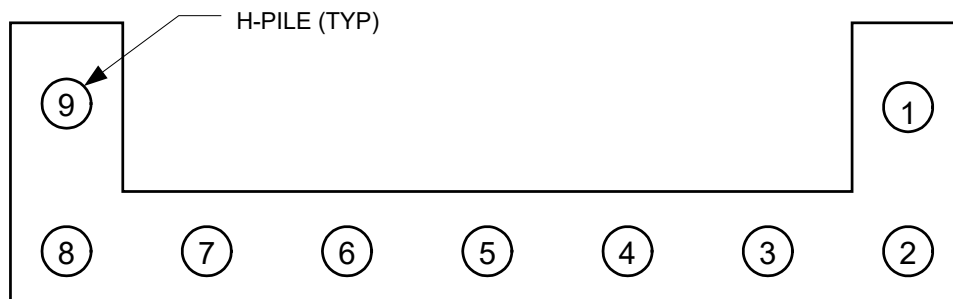

Track 3, Example 2-pile layout at an abutment

Because the bridge characteristics fall within integral abutment policy, the site has no unusual characteristics, the soils design engineer did not require further analysis, the project does not require staged construction, and construction will not be accelerated or delayed, there will be no need for lateral load or special analysis of the abutment piles. They may simply be designed for applied vertical load.

Step 4 - Estimate nominal geotechnical resistance for friction and end bearing

Based on the west abutment soil profile and BDM Tables 6.2.7-1 and 6.2.7-2, the final design engineer estimates the following nominal resistances for friction and end bearing as shown in the table below.

Track 3, Example 2-estimated nominal geotechnical resistance

Soil Stratum	Soil Description	Stratum Thickness (ft)	Average SPT N Value (blows/ft)	Estimated Nominal Resistance for Friction Pile (kips/ft)	Estimated Nominal Resistance for End Bearing (ksi)
1	Topsoil	3 below natural ground	---	---	---
2A	Firm Glacial Clay	7 remainder of prebore	---	---	---
2B	Firm Glacial Clay	20 below prebore	11	2.8	---
3	Very Firm Glacial Clay (30 feet below the natural ground elevation)	50	25	4.0	2

Step 5 - Select resistance factor to estimate pile length based on the soil profile and construction control

For a driven H-pile with construction control using WEAP, the following resistance factor is recommended to estimate the contract pile length for friction bearing in cohesive soil [BDM Table 6.2.9-1]. Only cohesive soil was present below the west abutment.

$$\phi = 0.65 \text{ for cohesive soil, averaged over the full depth of estimated pile penetration}$$

Step 6 - Calculate required nominal pile geotechnical resistance, R_n

Using the results from Steps 4 and 5, the required nominal pile resistance is

$$R_n = 129/0.65 = 198 \text{ kips/pile}$$

Step 7 – Estimate contract pile length, L

Based on the nominal resistance values in Step 4, the cumulative nominal geotechnical resistance, R_{n-BB} , per pile is calculated as follows, where D = depth in feet below the bottom of footing (which in this example also is the depth below natural ground elevation).

$$D_0 = 0 \text{ ft, } R_{n-BB0} = 0$$

$$D_1 = 10 \text{ ft, } R_{n-BB1} = R_{n-BB0} + 0 = 0$$

$$D_2 = 10 + 20 = 30 \text{ ft, } R_{n-BB2} = R_{n-BB1} + (2.8 \text{ kips/ft}) (20 \text{ ft}) = 0 + 56.0 = 56.0 \text{ kips}$$

$$D_3 = 30 + x \text{ ft}, R_{n-BB3} = R_{n-BB2} + (2.0 \text{ ksi}) (16.8 \text{ in}^2) = 56.0 + 33.6 = 89.6 \text{ kips}$$

$$D_4 = 30 + x \text{ ft}, x = (198 \text{ kips} - 89.6 \text{ kips})/4.0 \text{ kips/ft} = 27.1 \text{ ft}, D_4 = 30 + 27.1 = 57.1 \text{ ft}$$

The contract pile length includes a 2-foot embedment in the abutment footing and a 1-foot allowance for cutoff due to driving damage.

$$L = 57.1 + 2 + 1 = 60.1 \text{ feet}$$

The length for steel H-piles is specified in 5-foot increments [BDM 6.2.4.2]. Therefore, the contract pile length is rounded to 60 feet.

Step 8 - Estimate target nominal pile driving resistance, R_{ndr-T}

During the construction stage the pile will be retapped at 3 days, however, the basic retap information was developed a seven-day retap. Therefore, the target nominal pile driving resistance for a three-day retap was corrected based on the seven-day information.

First, select the construction resistance factor [BDM Table 6.2.9-3].

$$\phi_{TAR} = \mathbf{0.70 \text{ for cohesive soil}}, \text{ with required retap test after EOD}$$

Then determine the nominal geotechnical bearing resistance per pile.

$$R_n = 129/0.70 = 184 \text{ kips}$$

The average SPT N-value over the length of estimated pile embedment is needed for the setup factor chart.

$$N_a = [(20)(11) + (27)(25)]/47 = 19$$

From the 7-day retap curve in the graph below [partial BDM Figure 6.2.10],

$$R_n/R_{EOD} = 1.57$$

The target nominal geotechnical resistance at EOD is:

$$R_{EOD} = 184/1.57 = 117 \text{ kips} = 59 \text{ tons}$$

Determine the nominal resistance at 3 days. From the 3-day curve in the graph below,

$$R_n/R_{EOD} = 1.52$$

The target nominal geotechnical resistance at the 3-day retap then is:

$$R_{3\text{-day}} = (117)(1.52) = 178 \text{ kips} = 89 \text{ tons}$$

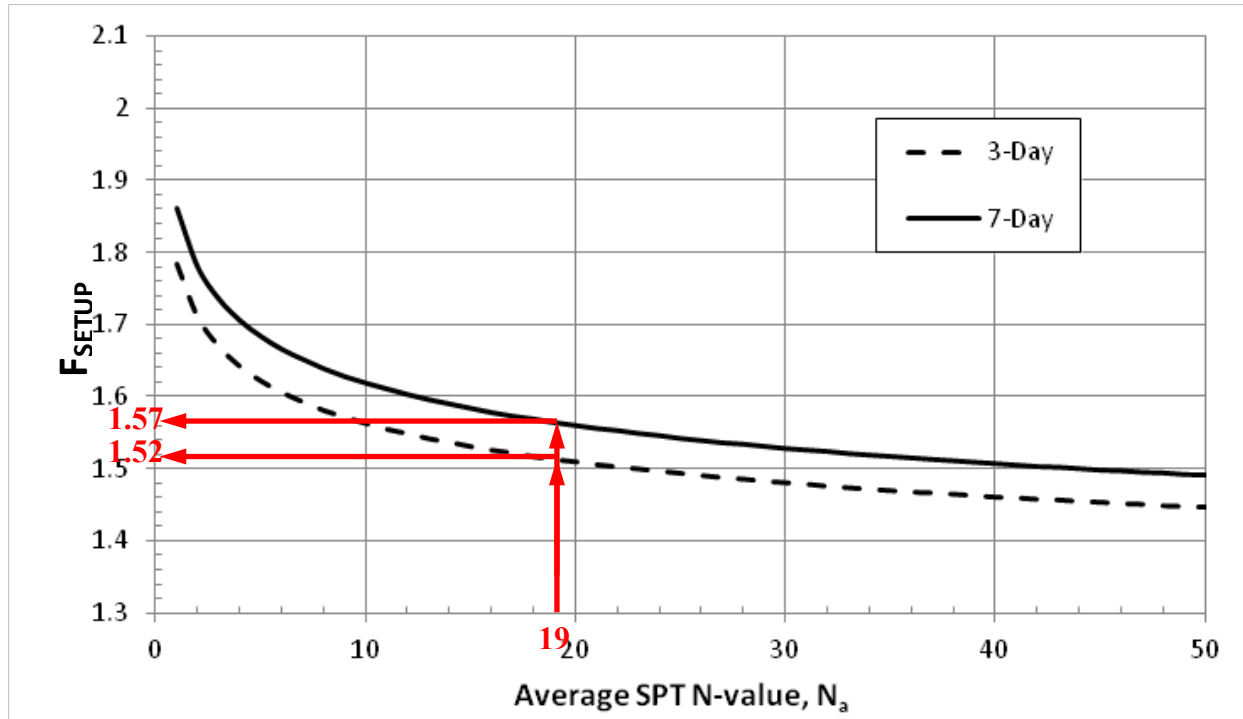

Track 3, Example 2-pile setup factor chart [partial BDM Figure 6.2.10]

Step 9 – Prepare CADD note for bridge plans

At this point the final design engineer selects the appropriate CADD notes and adds the specific pile load values to the notes [BDM 13.8.2].

E818: Abutment piles, LRFD contract length and resistance

THE CONTRACT LENGTH OF 60 FEET FOR THE WEST ABUTMENT PILES IS BASED ON A COHESIVE SOIL CLASSIFICATION, A TOTAL FACTORED AXIAL LOAD PER PILE (P_U) OF 129 KIPS, AND A GEOTECHNICAL RESISTANCE FACTOR (Φ) OF 0.65.

THE NOMINAL AXIAL BEARING RESISTANCE FOR CONSTRUCTION CONTROL WAS DETERMINED FROM A COHESIVE SOIL CLASSIFICATION AND A GEOTECHNICAL RESISTANCE FACTOR (Φ) OF 0.70. PILES ARE ASSUMED TO BE DRIVEN FROM A START ELEVATION AT THE BOTTOM OF PREBORE.

E819: Abutment piles, driving and construction control

THE REQUIRED NOMINAL AXIAL BEARING RESISTANCE FOR WEST ABUTMENT PILES IS 59 TONS AT END OF DRIVE. PILES SHALL BE RETAPPED AT THREE DAYS WITH A REQUIRED NOMINAL AXIAL BEARING RESISTANCE OF 89 TONS. THE PILE CONTRACT LENGTH SHALL BE DRIVEN AS PER PLAN UNLESS PILES REACH REFUSAL. CONSTRUCTION CONTROL

REQUIRES A WEAP ANALYSIS WITH BEARING GRAPH AND A RETAP AT THREE DAYS AFTER EOD.

Step 10 – Check the design

Within the Bridges and Structures Bureau at the Iowa DOT a final design engineer other than the bridge designer is assigned to give the bridge design an independent check at the time final plans are complete. During the checking process a final design engineer will review the soils package to ensure that all recommendations were followed and also will check structural, geotechnical, and drivability aspects of the design.

Other design organizations may perform checks at various stages of design rather than upon plan completion.

-----**END DESIGN PHASE**-----

-----**BEGIN CONSTRUCTION PHASE**-----

Step 11 – Request and check contractor’s hammer data and prepare bearing graph for WEAP control

After the bridge contract is let and prior to start of pile driving, the contractor completes Hammer Data sheets for the pile driving hammer that he/she plans to use. The Hammer Data sheets include all pertinent information including the cap (helmet) number and hammer identification information with details, hammer cushion, and pile cushion (where required), as well as pile size, pile length, and required (or target) nominal axial pile driving resistance. For state projects the Construction and Materials Bureau uses the data received to complete a WEAP analysis for construction control during pile driving. Results from the WEAP analysis are then used to prepare an LRFD Bearing Graph as shown in the figure below (without the factor of safety used for allowable stress design). The Bearing Graph includes hammer stroke height curves that relate blows per foot to nominal driving resistance, and identifies specific driving conditions, where driving stress is a concern.

Special Driving Conditions	Stroke (ft)	Monitor at 10 Blow Increments	Do NOT Exceed	Project No: Design Example DGT32	Graph No: XX-XXXX-XX-XXX
	7	-----	-----	Design No: XXX	Hammer No: XXXXXX
Blows per foot	8	-----	-----	County: XXXXX	Cap No: XXX
	9	-----	-----	Location: West Abutment	Pile Type: HP 10x57
				Hammer: Delmag D19-42	Pile Length: 60

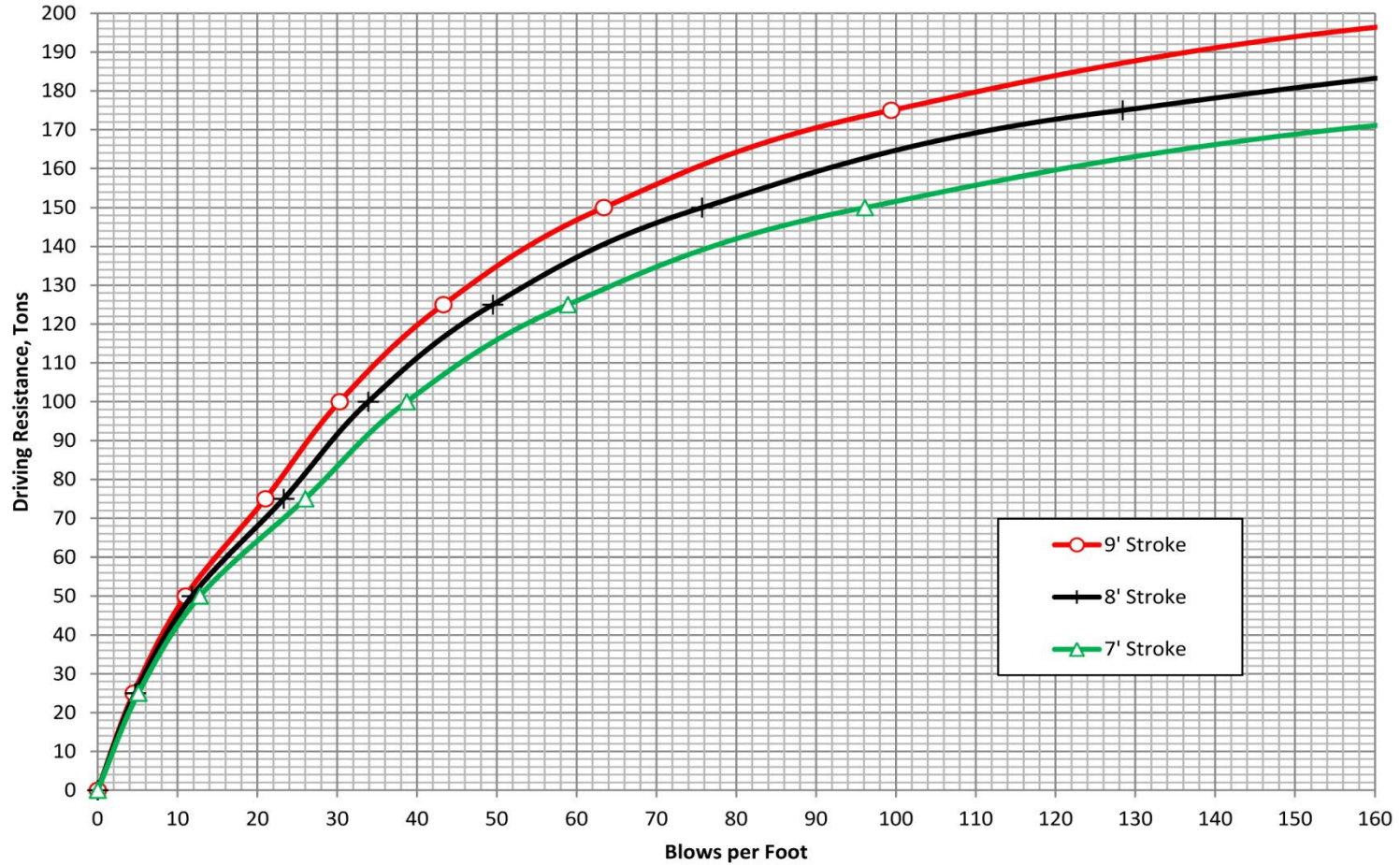

Track 3, Example 2-WEAP bearing graph for the west abutment

Step 12 - Observe construction, record driven resistance, and resolve any construction issues

During pile driving, the construction inspector records the hammer stroke and number of blows to advance the pile an equivalent penetration of 1 foot, and then converts the recorded information with the Bearing Graph to record the driven resistance per pile at EOD. This information is shown in the driving log below.

In this example the inspector would record the EOD values and observe and record retaps three days after EOD. Unless otherwise noted on the plans the number of retaps required would follow Iowa DOT policy in the standard specifications [IDOT SS 2501.03, M, 5].

At EOD at Pile 8, the construction inspector recorded a driving resistance of 56 tons (There is a slight error in the log; at 14 blows per foot the graph reads about 53 tons.), which is less than the target nominal pile driving resistance of 59 tons at EOD. However, no immediate pile extension is needed for Pile 8, since the construction control is based on planned retap at 3 days. Three days after EOD, Pile 8 was retapped, and the construction inspector recorded a driving resistance of 92 tons, which is greater than the target nominal pile driving resistance of 90 tons for 3-day retap. Therefore, Pile 8 meets the design requirement and no pile extension is needed.



ENGLISH LOG OF PILING DRIVEN WITH WAVE EQUATION

Project No. Someplace in Iowa Pile (Type and Size) HP 10x57
 County XXX (Wood Steel Concrete)
 Design No. XXX Hammer (Type & Model) Delmag D19-42
 Contractor XXXX (Gravity or Diesel manufacturer and model)
 Driving Graph No. XX-XXXX-XX-XXX Foundation Description West Abutment
 (North abut, Pier 1, etc.)
 Nominal Driving Resistance 59 (EOD) / 89 (3-Day Restrike) Tons Station of Foundation C.L. XXX+XX

Sketch foundation below, number each pile and show steel H-pile orientation as installed. Note battered piles on sketch, and give the amount of batter. Place name and certificate number of welder below if welding was necessary. Forward copies, including driving graph, as outlined in the construction manual. Note on drawing which pile has been logged.

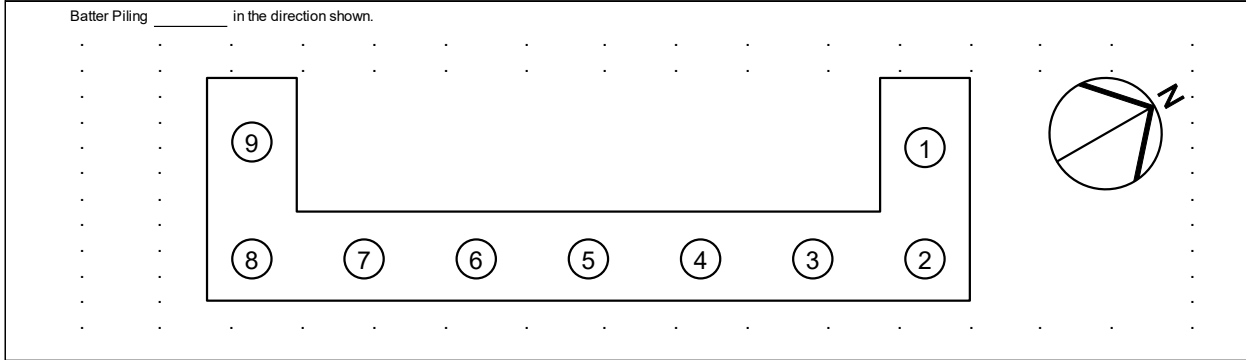

Pile No.	Date Driven	(1) Plan Length (ft.)	Length Cutoff (0.0 ft.)	Blows Per Foot	Ram Rise (ft.)	Driven Resistance (Tons)	RETAP (2)			PILE EXTENSIONS (3)					Welds (Count)	
							Date	Ram Rise (ft.)	Blows Per Foot	Driven Resistance (Tons)	Length Added (0.0 ft.)	Length Cutoff (0.0 ft.)	Ram Rise (ft.)	Blows Per Foot		Driven Resistance (Tons)
1	05-17-10	60	1.0	18	7.5	62	05-20-10	8	34	100						
2	05-17-10	60	1.0	21	8	68	05-20-10	7	36	95						
3	05-17-10	60	1.0	20	7	63	05-20-10	7.5	39	105						
4	05-17-10	60	1.0	25	8	78	05-20-10	8.5	40	115						
5	05-17-10	60	1.0	16	9	62	05-20-10	9	32	103						
6	05-18-10	60	1.0	20	8.5	70	05-21-10	8.5	38	111						
7	05-18-10	60	1.0	17	7.5	60	05-21-10	7	39	100						
8	05-18-10	60	1.0	14	7	56	05-21-10	7.5	32	92						
9	05-18-10	60	1.0	19	8.5	67	05-21-10	8	33	98						
---	---	---	---	---	---	---										

Total Welds: _____

- (1) Record in the Remarks section below if the pile length is anything other than the plan length at the beginning of drive.
- (2) Indicate date of retap in date column (1 day delay min.). List only pile actually checked.
- (3) Additional pile length to be authorized by Construction Office.

Plan Length: _____ Feet
 Extensions: _____ Feet

Welders Name: _____ Lab No.: _____ Exp. Date: _____

Total: _____ Feet

Remarks: _____

Inspector

Date

Project Engineer

Distribution: Construction (original), District, Project File

Track 3, Example 2-west abutment pile driving log